



MDOT RC-1602



Improving Bridges with Prefabricated Precast Concrete Systems

FINAL REPORT – DECEMBER 2013



Western Michigan University
Department of Civil & Construction Engineering
College of Engineering and Applied Sciences

RESEARCH

Intentionally left blank

**Technical Report
Documentation Page**

1. Report No. RC-1602	2. Government Accession No. N/A	3. MDOT Project Manager David Juntunen	
4. Title and Subtitle Improving Bridges with Prefabricated Precast Concrete Systems		5. Report Date December 31, 2013	
7. Author(s) Dr. Haluk Aktan and Dr. Upul Attanayake.		6. Performing Organization Code WMU	
9. Performing Organization Name and Address Western Michigan University 1903 West Michigan Avenue Kalamazoo, MI 49008		8. Performing Org Report No. N/A	
12. Sponsoring Agency Name and Address Michigan Department of Transportation Research Administration 8885 Ricks Rd. P.O. Box 30049 Lansing, MI 48909		10. Work Unit No. (TRAIS) N/A	
		11. Contract No. 2010-0297	
		11(a). Authorization No. Z2	
15. Supplementary Notes		13. Type of Report & Period Covered Final Report 10/1/2010 – 12/31/2013	
		14. Sponsoring Agency Code N/A	
16. Abstract <p>In order to minimize the impact of construction on the traveling public, MDOT utilizes innovative and specialized construction methods such as Accelerated Bridge Construction (ABC). Michigan, like other highway agencies in the region, has several challenges in specifying prefabricated bridge elements and systems (PBES) and accelerated bridge construction (ABC) techniques for bridge replacement projects. Among those challenges, the following are the most common: (1) justification of initial project costs, (2) defining a rational process for selecting ABC over conventional construction, (3) absence of PBES selection guidelines and proven standard and successful designs, (4) absence of constructability evaluation guidelines, and (5) questionable durability performance of PBES and connections.</p> <p>This research project was initiated with several objectives. They were achieved by (1) synthesizing the state-of-the-art practices, challenges, and lessons learned from the implemented ABC projects, (2) developing a Michigan-specific decision-making platform based on the site specific data to identify the optimal construction alternative between conventional construction and ABC, (3) developing a comprehensive list of connection details and cementitious materials for connections, (4) developing standard deck level longitudinal connection details for unremarkable bridges, (5) developing a template of special provisions for grout selection and application procedures, (6) documenting construction procedures, equipment, and implementation limitations, (7) developing a constructability review checklist, and (6) providing recommendations for further research and implementation of PBES based on constructability, maintainability, reparability, and durability.</p>			
17. Key Words Accelerated bridge construction, Concrete, Connection, Constructability, Decision-making, PBES, Performance, Reduced-weight.		18. Distribution Statement No restrictions. This document is available to the public through the Michigan Department of Transportation.	
19. Security Classification - report Unclassified	20. Security Classification - Page Unclassified	21. No of Pages 267 without appendices	22. Price N/A

Intentionally left blank

Improving Bridges with Prefabricated Precast Concrete Systems

Project Manager: Mr. David Juntunen, P.E.

Submitted to:



Submitted by

Dr. Haluk Aktan, P.E.
Professor
(269) 276 – 3206
haluk.aktan@wmich.edu

Dr. Upul Attanayake, P.E.
Assistant Professor
(269) 276 – 3217
upul.attanayake@wmich.edu



Western Michigan University
Department of Civil & Construction Engineering
College of Engineering and Applied Sciences
Kalamazoo, MI 49008
Fax: (269) 276 – 3211

Intentionally left blank

DISCLAIMER

“This publication is disseminated in the interest of information exchange. The Michigan Department of Transportation (hereinafter referred to as MDOT) expressly disclaims any liability, of any kind, or for any reason, that might otherwise arise out of any use of this publication or the information or data provided in the publication. MDOT further disclaims any responsibility for typographical errors or accuracy of the information provided or contained within this information. MDOT makes no warranties or representations whatsoever regarding the quality, content, completeness, suitability, adequacy, sequence, accuracy or timeliness of the information and data provided, or that the contents represent standards, specifications, or regulations.”

Intentionally left blank

ACKNOWLEDGEMENTS

This project is funded by the Michigan Department of Transportation. The authors would like to acknowledge the support and effort of Mr. David Juntunen for initiating this research. The authors also wish to acknowledge the continuing assistance of the Research Advisory Panel (RAP) members in contributing to the advancement of this study. Contribution of Drs. Abudayyeh and Hu for the success of the project is greatly appreciated. Contribution of graduate students: Abdul Wahed Mohammed, Ramzi Muftah Abdullallah, Mohamed Rusthi, Alp Servi, and Mete Bilgin is highly appreciated.

Intentionally left blank

EXECUTIVE SUMMARY

INTRODUCTION

Michigan has eleven corridors of National/International significance. The decision principles to guide the management, operation, and investments on these corridors include strategies to reduce delays and minimize construction impacts. MDOT's vision for transportation states that, "*MDOT will embrace technology and technological development. The department will use innovation in every aspect of what it builds, how it builds, and in every service that is provided.*" In order to minimize the impact of construction on the traveling public, MDOT utilizes innovative and specialized construction methods such as ABC (MDOT 2007). The first such implementation of *Accelerated Bridge Construction* was in 2008. ABC was used to construct Michigan's first totally prefabricated full-depth deck panel bridge system, the Parkview Avenue Bridge. The bridge carries Parkview Avenue over US-131 freeway. MDOT has completed a few more ABC projects since then.

Michigan, like other highway agencies in the region, has several challenges related to prefabricated bridge elements and systems (PBES) and accelerated bridge construction (ABC). Among those challenges, the following are the most common: (1) justification of initial project costs, (2) a rational process for selecting ABC over conventional construction, (3) lack of access to PBES selection guidelines and proven standard and successful designs, (4) constructability evaluation guidelines, and (5) durability performance of PBES and connections.

This project is designed for addressing the issues by documenting current national and international state-of-the-art practices in PBES design, construction, and demolition, and associated potentials and limitations. The process is to analyze the existing practices and systems and then to identify fully prefabricated precast concrete systems suitable for Michigan. The specific objectives of the study are as follows:

- (1) Develop a comprehensive list of prefabricated bridge elements and systems (PBES) and associated potentials and limitations with attention to durability, repairability, and maintainability.
- (2) Develop a Michigan-specific decision-making platform.

- (3) Evaluate the performance of selected PBES bridges.
- (4) Develop a comprehensive list of connection details and cementitious materials for durable connections and closures suitable for Michigan exposure conditions.
- (5) Develop standard deck level longitudinal connection details for unremarkable bridges.
- (6) Document construction procedures, equipment, and implementation limitations; and develop recommendations for deconstruction of selected PBES bridges.
- (7) Provide recommendations for further research and implementation of selected systems.

To achieve these objectives, this project was organized into five tasks: (1) review the state-of-the-art literature, (2) assess the performance, challenges and lessons learned, (3) develop a Michigan-specific ABC decision-making platform, (4) recommend PBES, connection details, and cementitious grout or closure material suitable for Michigan, and deconstruction procedures for selected PBES bridges, and (5) provide recommendations for further research and ABC implementation.

LITERATURE REVIEW

Literature on the following topics was reviewed:

1. The PBES currently being implemented under ABC and the potentials and limitations associated with each structural system,
2. Connection (joint) details between prefabricated elements or systems,
3. The grout materials for connections and their application procedures,
4. The accelerated construction and deconstruction methods and equipment,
5. The constructability benefits, implementation barriers, and essential elements of a constructability program, and
6. State-of-the-art decision making models.

Prefabricated Bridge Elements and Systems

The PBES were categorized into four groups, which are a) Girders, b) Decks, c) Modular superstructure elements and systems, and d) Substructure elements. A summary of key features identified through the literature review is presented below.

- a) Girders: Different precast prestressed concrete girder types and sections have been developed by considering site constraints such as span, underclearance, aesthetics, loading, and exposure. The implementation of the girders in ABC requires partial-

- depth or full-depth deck panels. In addition, precast prestressed concrete girders need testing and validation when non-standard sections and spans are used. Hence, standardization of efficient girder sections (in terms of capacity and material use) will help the designers to select the sections for preliminary design once the site constraints are known. Most of the girders are suitable for short and short-to-medium span bridges (up to 130 ft). A few of them are standardized and the designers, fabricators, and contractors are familiar with the potentials and limitations of using them in a project. However, the girders available for medium span bridges (130 ft to 260 ft) are limited. Girder splicing with post-tensioning could potentially increase the span up to 220 ft.
- b) Decks: Transverse prestressing and longitudinal post-tensioning in a full-depth deck panel system are important to enhance bridge durability performance. Transverse prestressing provides better crack control, and allows using thinner deck panels and wider spacing of supporting girders. Longitudinal post-tensioning can be designed such that deck remains under compression under all service load conditions, resulting in a durable system.
- c) Modular superstructure elements and systems: The *modular superstructure elements* represent the prefabricated elements which are placed side-by-side and connected using moment or shear transfer details to form a complete bridge superstructure. And the *modular superstructure systems* are developed by combining multiple girders and a precast slab. Excluding the segmental box-beam section, the rest of the modular superstructure elements and systems are suitable for short span (i.e., 20 ft to 60 ft) and short-to-medium span (i.e., 60 ft to 130 ft) bridges. The bridge superstructures that are built using modular superstructure elements (such as trapezoidal box, double-tee, inverted-T, or NEXT F beams) require a cast-in-place concrete deck; hence project duration will be extended. The bridge superstructures that are built using modular superstructure elements such as a decked box-beam, a decked bulb-tee beam, a NEXT D beam, and a Pi-girder (as well as modular superstructure systems such as INVERSESET™ and a decked steel girder system) use a hot-mix asphalt (HMA) layer with a waterproofing membrane, an epoxy overlay, or a latex modified concrete overlay as the wearing surface.

- d) Substructure elements: The most widely used prefabricated substructure elements are the precast pier/bent caps. Precast columns, precast abutment stems, and precast pile caps were also implemented on several projects. A majority of the prefabricated substructure elements, which are used in ABC projects, are not standardized. The substructure element weight is a limitation; hence, innovative sections have been developed that require further research for standardization.

Connection Details

The connection details were categorized as superstructure and substructure connections. The superstructure connection was further classified into deck level transverse, deck level longitudinal, deck to girder, continuity details over pier or bent, and continuity details at abutment. The substructure connection was further classified into pile cap or abutment stem to pile, abutment wall to footing, column to footing, pier or bent cap to column, vertical connection between elements, and segmental columns or piers. The potentials and limitations of using available PBES connection details in Michigan were evaluated with respect to site exposure conditions, load transfer mechanism, durability, constructability, and connection dimensions and tolerances. Above all, the standard details for longitudinal connections at deck level were developed for bridge superstructures with precast prestressed concrete girders.

Cementitious Grout Materials and Special Mixes

Cementitious grout materials and special mixes for PBES connections were reviewed. The properties of commercial and non-commercial grout materials and special mixes such as freeze/thaw resistant, compressive strength, volume stability, initial setting time, grout pocket dimensions, working temperature range, site constraints and limitation, and curing requirements were summarized. Further, the performance requirements of compressive strength and non-shrink properties provided in AASHTO and ASTM specifications were also documented.

Accelerated Bridge Construction and Deconstruction Techniques

The techniques used for accelerated bridge construction and demolitions were reviewed. The most commonly used construction techniques are lifting and placing of components or the entire structure, incremental launching, the use of Self-Propelled Modular Transporters

(SPMTs), skidding or sliding, and rotating them into place. The accelerated bridge demolition techniques include the use of SPMTs and traditional demolition techniques such as ball and crane, hydraulic attachments, drilling and sawing, explosives, and hydrodemolition. While selecting deconstruction methods and equipment the workers' safety, surrounding utility protection, adjacent structure protection, location and accessibility, shape and size of the structure, time constraints, maintenance of traffic (MOT), financial constraints, and stability of the structure are a few important parameters that need to be considered.

Constructability

The constructability benefits, implementation barriers, and essential elements of a constructability program were reviewed. Employing a constructability program in projects, despite the associated additional costs, has offered many advantages including the reduction in overall project and construction costs, the decrease in the number of construction change orders, the improvement in project quality and safety, and the reduction of construction duration. In order to achieve the goals of a constructability program, the following key elements need to be considered.

- a) Committing to constructability,
- b) Establishing a constructability team,
- c) Defining constructability objectives and measures,
- d) Selecting a project contracting strategy, and
- e) Developing constructability procedures.

However, there are some barriers and challenges involved with the implementation of a constructability program, which are (i) traditional contracting practices in competitive bidding environments, (ii) lack of owner initiatives in committing funds and/or the resources, (iii) lack of construction experience and fundamental knowledge by the designers, (iv) rigid specifications that limit design flexibility, (v) reluctance of the agency to invest time or money into training the project personnel, and (vi) designers may have concerns such as discovering inadequate designs, drawings lacking detail, or incomplete specifications. The maximum benefits from a constructability review can be achieved through the early involvement of individuals with construction knowledge and experience in the design of a project. Documentation of lessons learned reports is important for continuous improvement of the constructability process.

ABC Decision-Making Models

The state-of-the-art decision-making models and pertinent mathematical formulations were reviewed. The most commonly used decision-making models, which do not incorporate any mathematical formulation, use the common strategy of requiring *Yes* or *No* inputs without any relative significance of critical parameters. Several other decision-making processes require a significant amount of data collected through survey and research. Since ABC techniques are relatively new and do not have a large database of pertinent parameters, the use of those models is not feasible at this time.

The Analytical Hierarchy Process (AHP), which allows incorporating both qualitative and quantitative information into the decision-making process, has been widely used in many fields. This mathematical model has been recently used to develop decision-making models related to various ABC activities. One such example is the decision-making software developed by the Oregon State University under the FHWA-sponsored pool fund study. This software utilizes AHP to quantify the qualitative trade-offs between various parameters to derive the overall preference rating of conventional construction and ABC. However, several limitations were identified with this model and they are provided below.

- a) Project specific data is not provided; hence, the decision maker has to rely upon his/her experience to make decisions without any supportive information.
- b) The software does not allow integrating predefined criteria based on site or state specific data. If such a feature is available, it could have reduced the manual pair-wise comparisons and increased the efficiency of the decision-making process.
- c) The normalized preference ratings are calculated through an approximate method, and the consistency ratio is not evaluated. The inability in addressing the consistency ratio while using the approximate method for calculating the local priorities is a major shortcoming. This may also lead to erroneous results. Moreover, as the number of parameters used for pair-wise comparison increases, so does the order of matrices used in the calculation process. It is difficult to achieve consistency in higher order matrices, because the number of transitive rules to be satisfied increases in a quadratic manner. Hence, implementation of the principal eigenvalue calculation process is required to achieve reliable results.

ASSESSMENT OF THE PERFORMANCE, CHALLENGES AND LESSONS LEARNED

The durability performance of (a) full-depth deck panel systems, (b) the bridges constructed using Self Propeller Modular Transporters (SPMT), (c) the bridges constructed using slide-in techniques, and (d) side-by-side box-beam bridges were reviewed. The outcome of the review is (a) the causes of premature deterioration, (b) potential measures to enhance durability performance, and (c) recommendations for future research. In addition, a large number of ABC projects were reviewed, and the challenges and lessons learned were documented. The challenges and lessons learned were synthesized and categorized into three major groups.

1. Project planning and design
2. Precast element fabrication.
3. Construction operations and tolerances.

The outcome of this synthesis, in conjunction with the experience of the project team and review of constructability benefits, implementation barriers, and essential elements of a constructability program, led to the development of a constructability review checklist for ABC projects.

MICHIGAN-SPECIFIC ABC DECISION-MAKING PLATFORM

State-of-the-art decision making models were reviewed, and the deficiencies pertaining to the existing models were documented. To overcome the limitations in the available decision-making processes, a multi-criteria decision-making process and a guided software were developed. The software is named as the Michigan Accelerated Bridge Construction Decision-Making (Mi-ABCD) that evaluates the Accelerated Bridge Construction (ABC) vs. Conventional Construction (CC) alternatives for a particular project. The process incorporates project-specific data and available user-cost and life-cycle cost models to help the decision makers with quantitative data to make informed decisions on bridge construction alternatives. The software was developed using Microsoft Excel and Visual Basic for Applications (VBA) scripts. The multi-criteria decision-making process developed during this project provides solutions to many issues in ABC decision-making. The decision-making framework provides a *preference rating* of each construction alternative. The contribution of each parameter to the *preference ratings* is also provided. The decision-making platform developed in this project

is an advancement over the available decision-making models by addressing their shortcomings.

RECOMMENDATIONS OF PBES AND THEIR ASSOCIATED DETAILS

After synthesizing the state-of-the-art PBES practices in bridge construction and deconstruction, durability performance, and lessons learned, the PBES that can be readily implemented in Michigan are recommended without reservation by considering constructability, maintainability, repairability, and durability. The connection details between the PBES are selected based on the exposure conditions, load transfer mechanism, durability, constructability, dimensions and tolerances, and formwork requirement. Standard details for longitudinal connection at the deck level are presented and recommended for implementation.

The attributes of selected PBES, formwork for grouting of connections, constructability challenges, and other limitations are also presented. The deconstruction techniques and equipment for each of the selected PBES are also discussed.

Several challenges were identified during the grout selection process; therefore, to address those challenges, a template of special provision for grout selection and application is presented in this report. Further, the importance of developing a database of material properties suitable for establishing the connection between prefabricated components and making it available to the designers is discussed.

ABC CONSTRUCTABILITY REVIEW CHECKLIST

An ABC constructability review checklist is presented in this report. The checklist needs to be reviewed by the project development team and the project delivery team. The review of the checklist before starting the bidding process will help to avoid repeated mistakes of the past, and to complete projects in the most efficient and cost effective manner. This ABC constructability review checklist can be fine-tuned by monitoring the construction activities including prefabrication and by conducting a post-construction program to document the challenges and lessons learned.

SUMMARY AND CONCLUSIONS

The project was organized into five tasks: (1) review the state-of-the-art literature, (2) assess the performance, challenges and lessons learned, (3) development of a Michigan specific ABC decision-making platform, (4) recommend PBES, connection details, and cementitious grout or closure material suitable for Michigan, and deconstruction procedures for selected PBES bridges, and (5) provide recommendations for further research and ABC implementation.

A Michigan-specific decision-making process that was supported by a software platform was developed. The decision-making process was structured to allow the site-specific analysis of the optimal construction alternative decision between conventional construction and ABC. The decision-making process incorporates parameters that are evaluated based on site specific data. It also incorporates judgment of planning, design, transportation, and construction experts. To guide the experts in providing their judgments, supportive information on the site specific data is generated and made available. Mathematical fundamentals of the decision-making platform are based on principal eigenvector calculations to deal with the potential variability of expert judgments. The result is presented as a *preference rating* of each construction alternative. The contribution from each parameter to the *preference ratings* is also provided. The decision-making process and the platform developed in this project is an advancement over the available decision-making models by addressing their shortcomings.

The prefabricated bridge elements and systems, connection details, and grout or special mixes appropriate for the Michigan exposure provide a significant contribution to this project. After synthesizing the state-of-the-art practices and performance and lessons learned from ABC implementations, potential PBES for immediate implementation are identified. These PBES recommendations are based on constructability, maintainability, reparability, and durability (CMRD). The suitable connections between the PBES are identified considering the exposure conditions, load transfer mechanism, constructability, durability, dimensions and tolerances, and formwork requirements for grout or special mix placement. Also, standard details for the longitudinal deck level connection were developed for bridge superstructures with precast prestressed girders. The details in the MDOT Bridge Design Guide format is presented in Appendix I.

Nonspecific grout or special mix recommendations for a connection are not practical because the material selection is based on project parameters. The parameters are (1) site specific exposure conditions, (2) grout pocket dimensions, (3) application procedures and limitations, (4) curing requirements and also (5) grout properties such as compressive strength, volume stability, initial setting time or working time, and working temperature range. The grout materials need to be tested and evaluated for the particular application before field implementation. In order to address these difficulties, a template of special provisions for grout selection and application is presented in the report. In addition to that, a database of material properties suitable for the connection between prefabricated components is also provided in the report.

An ABC constructability review checklist is presented in the report. This checklist can be used to guide the project development and delivery teams in constructability assessments before the bidding process. Moreover, the checklist will be useful to overcome mistakes documented in earlier ABC implementations. The checklist will also help with project management, scheduling and cost control.

TABLE OF CONTENTS

ACKNOWLEDGEMENTS	ix
EXECUTIVE SUMMARY	xi
TABLE OF CONTENTS	xxi
LIST OF TABLES	xxv
LIST OF FIGURES	xxvii
1 INTRODUCTION	1
1.1 Overview	1
1.2 Project Objectives and Tasks	2
1.3 Report Organization	3
2 STATE-OF-THE-ART LITERATURE REVIEW	5
2.1 Overview	5
2.1.1 ABC/ABR Definition.....	5
2.1.2 Objective and Approach	5
2.2 Prefabricated Bridge Elements and Systems.....	6
2.2.1 Introduction.....	6
2.2.2 Girders.....	11
2.2.3 Decks.....	14
2.2.4 Modular Superstructure Elements and Systems	15
2.2.5 Substructure Elements	20
2.2.6 Miscellaneous	21
2.3 Connection Details	22
2.3.1 Load Transfer Mechanism	23
2.3.2 Constructability.....	23
2.3.3 Connection Dimensions and Tolerances.....	24
2.4 Grout Materials for Connections and Application Procedures	25
2.4.1 Review Objective.....	25
2.4.2 Commercially Available Grouts	26
2.4.3 Commercial Grout Properties Documented in the Literature	33
2.4.4 Non-Commercial Grout and Mortar	35

2.4.5	Grouting Operation	38
2.4.6	Summary and Conclusions	41
2.5	Accelerated Bridge Construction and Deconstruction Methods and Equipments	42
2.5.1	Accelerated Bridge Construction Methods and Equipment.....	42
2.5.2	Accelerated Bridge Deconstruction Methods and Equipment.....	43
2.5.3	Safety Issues in Bridge Demolition	50
2.6	Constructability and Elements of a Constructability Program	52
2.6.1	Constructability.....	52
2.6.2	Constructability Benefits	53
2.6.3	Constructability Implementation Challenges.....	54
2.6.4	Essential Elements of a Constructability Program.....	55
2.7	State-of-the-Art Decision-Making Models	57
2.7.1	Decision-Making for Outsourcing and Privatization of Vehicle and Equipment Fleet Maintenance	57
2.7.2	Matrix–Based Decision Support Model for Pavement Rehabilitation Activities on High-Volume Roads.....	58
2.7.3	Linear Programming for Decision-Making	65
2.7.4	Scoring Model for Decision-Making.....	65
2.7.5	Analytic Hierarchy Process (AHP) for Decision-Making	67
2.7.6	Multi-Criteria Decision-Making Approach for Highway Slope Hazard Management.....	72
2.7.7	Application of the AHP to Select Project Scope for Video-Logging and Pavement Condition Data Collection.....	74
2.7.8	Accelerated Construction Decision-Making Process for Bridges	76
2.7.9	PBES Decision-Making Model.....	78
2.7.10	Utah DOT ABC Decision-Making Process	81
2.7.11	A Planning Phase Decision-Making Software for ABC.....	85
2.7.12	Summary of Limitations in the Available Decision-Making Models.....	92
3	PERFORMANCE, CHALLENGES, AND LESSONS LEARNED	95
3.1	Overview	95
3.2	Field Performance of Bridges Constructed Using ABC Techniques	95

3.3	Causes and Methods to Abate Premature Deterioration of Full-depth Deck Panel Systems.....	96
3.4	Causes and Methods to Abate Premature Deterioration of Bridges Moved Using SPMT.....	100
3.5	Causes and Methods to Abate Premature Side-by-Side Box-Beam Deterioration .	101
3.6	Challenges and Lessons Learned	102
3.6.1	Project Planning and Design.....	102
3.6.2	Precast Element Fabrication	104
3.6.3	Construction Operations and Tolerances	104
4	THE MICHIGAN ACCELERATED BRIDGE CONSTRUCTION DECISION-MAKING (Mi-ABCD)	107
4.1	Overview	107
4.2	The Mi-ABCD Process	107
4.2.1	Sample Popup Menus and Datasheet.....	107
4.2.2	User Menus	108
4.2.3	Implementation of Mi-ABCD Process.....	109
4.3	Mi-ABCD Capabilities and Advancement.....	117
4.4	Summary	118
5	CONSTRUCTION AND DECONSTRUCTION PROCEDURES AND DETAILS FOR SELECTED BRIDGE STRUCTURAL SYSTEMS ..	121
5.1	PBES Recommendations.....	121
5.1.1	Prestressed Concrete (PC) Girders.....	122
5.1.2	Full-Depth Deck Panels	126
5.1.3	Modular Superstructure Elements.....	130
5.1.4	Modular Superstructure Elements with an Implementation Potential	135
5.1.5	Modular Superstructure Systems	142
5.1.6	Substructure Elements and Reduced-Weight Options.....	144
5.1.7	Substructure Elements with Implementation Potential.....	154
5.2	Connection Details	158
5.2.1	Recommended Superstructure Connection Details	158

5.2.2	Recommended Substructure Connection Details.....	171
5.3	Grout materials	185
5.3.1	A Grout Selection Example	185
5.3.2	Recommendation for Grout Selection	187
5.4	Deconstruction Methods and Equipments.....	189
5.4.1	Deconstruction Techniques.....	190
5.4.2	Deconstruction of the Recommended Bridge Systems.....	194
6	CONSTRUCTABILITY MODEL FOR ABC PROJECTS	201
6.1	Reviewed by the Project Development Team	202
6.2	Reviewed by the Project Delivery Team.....	206
6.3	Summary	209
7	SUMMARY, CONCLUSIONS, AND RECOMMENDATIONS.....	211
7.1	Summary and Conclusions.....	211
7.2	Recommendations	213
7.3	Recommendations for Implementation	219
8	BIBLIOGRAPHY	221
APPENDIX A: Prefabricated Bridge Elements and Systems		
APPENDIX B: Connection Details between Prefabricated Elements		
APPENDIX C: Performance of Bridges Constructed using ABC Techniques		
APPENDIX D: ABC Challenges and Lessons Learned		
APPENDIX E: Mi-ABCD User Manual		
APPENDIX F: Drawings of Full-Depth Deck Panels from Utah DOT		
APPENDIX G: Drawings of Bulb-Tee Girders from Utah DOT		
APPENDIX H: Details of NEXT D Beam from PCI-NE		
APPENDIX I: Standard Longitudinal Connection Details		
APPENDIX J: Special Provision for Grouting PBES Connections		

LIST OF TABLES

Table 2-1. Girder Types and Span Length with 80 kips Weight Limit	7
Table 2-2. Standard PC I-Girders, Spread Box Girders, and Girders with Spliced Details (Source: MDOT-BDM 2013; Castrodale and White 2004)	12
Table 2-3. Depth and Span Range of Utah Bulb-Tee Girders (Source: UDOT 2010b)	12
Table 2-4. Depth and Span Range of NEBT Girders (Source: PCI NE 2011)	12
Table 2-5. NU 900 I-Girder Specifications (Source: Morcoux et al. 2011).....	14
Table 2-6. NU I-Girder Series Specifications (Source: Hanna et al. 2010b).....	14
Table 2-7. Attributes of Adjacent Box-beams (Source: MDOT-BDM 2013).....	17
Table 2-8. Attributes of Trapezoidal Box Girders (Source: Badie et al. 1999).....	17
Table 2-9. Summary of Commercial Grout Properties	27
Table 2-10. Summary of Commercial Grout Properties	28
Table 2-11. General Requirement for Grouting Materials.....	30
Table 2-12. Experimental Data for Neat and Extended Grouts (Source: Scholz et al. 2007)	34
Table 2-13. Comparison of Manufacturer Data and Laboratory Test Data.....	34
Table 2-14. UHPC Mix Design (Source: Graybeal 2010a)	36
Table 2-15. UHPC Material Properties (Source: Graybeal 2010a)	36
Table 2-16. Type R-2 Grout Description (Source: Aktan et al. 2009)	37
Table 2-17. Type R-2 Grout Mix Design.....	37
Table 2-18. Compressive Strength of Type-R-2 Grout (Source: Aktan et al. 2009).....	37
Table 2-19. Mix Design for High Performance Concrete (Source: French et al. 2011).....	38
Table 2-20. Fundamental Scale for AHP Pair-Wise Comparison (Source: Saaty 1995).....	69
Table 2-21. Mean Weights of Parameters from the Survey (Source: Salem and Miller 2006)	77
Table 2-22. AHP Pair-Wise Comparison Matrix Developed through Back-Calculation from Mean Percentage Weights (Source: Salem and Miller 2006).....	77
Table 2-23. Matrix for High-Level Decision-Making on PBES (Source: Ralls 2005).....	80
Table 2-24. UDOT ABC Scoring Sheet (Source: UDOT 2010a).....	83
Table 2-25. Total Score Calculation of UDOT ABC Parameters (Source: UDOT 2010a)...	84
Table 4-1. Comparison of FHWA/OSU Decision Tool and Mi-ABCD Features	118
Table 5-1. Depth and Span Range of Utah Bulb-Tee Girders (Source: UDOT 2010b).....	125

Table 5-2. Attributes of Precast Adjacent Box-beams Used in Michigan (Source: MDOT-BDM 2013)..... 136

Table 5-3. Comparison of Bent Cap Weight Reduction 155

Table 5-4. Recommended Connection Details for Substructure 171

Table 5-5. Recommended Grouts for the Given Project Requirements 187

LIST OF FIGURES

Figure 2–1. Prefabricated bridge elements and systems	10
Figure 2–2. Classification of prefabricated element connection details	22
Figure 2–3. (a) Typical transverse connection detail of a full-depth deck panel system, and (b) zero tolerance leading to cracking at panels after post-tensioning	24
Figure 2–4. Field bending of reinforcement to overcome space issues (Source: http://www.flickr.com/photos/iowadot)	25
Figure 2–5. UHPC grouted dowel pockets in UHPC girders (Source: Bierwagen 2009)	35
Figure 2–6. Grouting adjacent box-beam shear keys using type R-2 grout (Oakland Drive over I-94, MI)	40
Figure 2–7. Pumping W.R. Meadows Sealight CG-86 non-shrink grout (Source: Oliva et al. 2007)	40
Figure 2–8. Grouting of full-depth deck panel connections (Source: Courtesy of MDOT)..	40
Figure 2–9. Joint details of panel-to-prestressed concrete I-girder connection with confined space, sharp edges, and corners (Source: Culmo 2009)	41
Figure 2–10. Transportation of the Warren Farm Bridge (Source: Anumba et al. 2003).....	45
Figure 2–11. Removal of the bridge using SPMT system (Source: Ardani et al. 2009)	45
Figure 2–12. Hydraulic Jack attached on the bridge (Source: Singh et al. 2008; Starmer and Witte 2006)	46
Figure 2–13. Hydraulic Sliding System (Source: Ardani et al. 2010a)	47
Figure 2–14. Equipment used in traditional bridge demolition process	48
Figure 2–15. Remote demolition machine Brokk 330 (Source: http://www.brokkinc.com/brokk-330.html).....	49
Figure 2–16. High-level outsourcing decision process (Source: Wiegmann and Sundararajan 2011)	58
Figure 2–17. The secondary-level flow chart for process 1 to identify critical internal and external conditions (Source: Wiegmann and Sundararajan 2011)	58
Figure 2–18. Preliminary strategy selection matrix (Source: Carson et al. 2008).....	61
Figure 2–19. Secondary strategy selection matrix for (a) construction, (b) traffic management, and (c) public information (Source: Carson et al. 2008).....	63
Figure 2–20. Part of the interdependency matrix (Source: Carson et al. 2008).....	64

Figure 2–21 BCP comparison objective matrix (Source: El-Diraby and O’Conner 2001) ...	66
Figure 2–22. Graphical representation of the AHP	68
Figure 2–23. Container yard handling system decision tree (Source: Moghadam et al. 2009)	71
Figure 2–24. Membership functions and linguistic values (Source: Liang and Pensomboon 2010)	73
Figure 2–25. Decision tree from expert choice software (Source: Larson and Forman 2007)	75
Figure 2–26. Sensitivity analysis results for corresponding alternatives from expert choice software (Source: Larson and Forman 2007)	76
Figure 2–27. Final evaluation of construction alternatives (Source: Salem and Miller 2006)	77
Figure 2–28. Flowchart for high–level decision-making on PBES (Source: Ralls 2005).....	79
Figure 2–29. UDOT ABC decision chart (Source: Ralls 2008)	82
Figure 2–30. Modified UDOT ABC decision chart (Source: UDOT 2010a).....	84
Figure 2–31. Default criteria hierarchy of the AHP decision-making software (Source: Doolen 2011)	87
Figure 2–32. Graphical user interface of the AHP decision-making software (Source: Doolen 2011)	88
Figure 2–33. Qualitative pair-wise comparisons in AHP decision-making software (Source: Doolen 2011)	88
Figure 2–34. AHP decision-making software evaluation result for a prototype site.....	91
Figure 2–35. Plot of sensitivity analysis results from AHP decision-making software for a prototype site	91
Figure 4-1. Sample popup menus and datasheet.....	108
Figure 4-2. User menus.....	109
Figure 4-3. (a) Project information and (b) decision-making parameters for highway over highway project	110
Figure 4-4. Site specific data and traffic data	111
Figure 4-5. Life-cycle cost data	112
Figure 4-6. Preference ratings and comments provide by User-1	113

Figure 4-7. User-3 provides <i>Preference Ratings</i> while observing previous users' comments	114
Figure 4-8. Results in chart format	115
Figure 4-9. Results in tabular format	116
Figure 4-10. Interface of the decision tool developed by Doolen (2011).....	117
Figure 5-1. Precast bulb-tee girders (Source: UDOT 2010b).....	124
Figure 5-2. Precast bulb-tee with post-tensioning in the web (Source: Castrodale and White 2004).....	126
Figure 5-3. Standard full-depth deck panel applications (Source: UDOT 2010b)	127
Figure 5-4. Stage construction configuration for full-depth deck panels (Source: UDOT 2010b).....	129
Figure 5-5. Typical section of a decked bulb-tee girder (Source: PCI 2011).....	132
Figure 5-6. Decked bulb-tee girder (Source: CPMP 2011)	132
Figure 5-7. Decked box-beam section (Source: MDOT M-25 over White River Bridge plans 2010).....	134
Figure 5-8. Adjacent box-beams that require a wearing surface (Source: CPCI 2006)	137
Figure 5-9. Old detail of the inverted-T precast slab.....	138
Figure 5-10. New detail proposed by the NCHRP for the inverted-T precast slab	139
Figure 5-11. Reinforcement cage at longitudinal joint of the inverted-T precast slab	140
Figure 5-12. NEXT D beam element (Source: PCI NE 2011)	141
Figure 5-13. Decked steel girder system (Source: MassDOT 2011; IowaDOT 2011).....	143
Figure 5-14. Abutment wall on spread footing (Source: MDOT M-25 over White River Bridge Plans)	145
Figure 5-15. Segmental abutment with redundant pile cavities (Source: Culmo 2009).....	146
Figure 5-16. Template used for maintaining pile driving tolerances (Source: Photo courtesy of MDOT).....	147
Figure 5-17. Concrete slab on ground to maintain the proper grade for placing the abutment stem (Source: Photo courtesy of MDOT).....	148
Figure 5-18. Octagonal column (Source: UDOT 2010b)	149
Figure 5-19. Square/Rectangular column (Source: IowaDOT 2011)	149
Figure 5-20. Rectangular bent cap (Source: http://facilities.georgetown.org/2009)	151

Figure 5-21. Trapezoidal bent cap (Source: Restrepo et al. 2011)	151
Figure 5-22. UDOT standardized bent cap sections (Source: UDOT 2010b)	151
Figure 5-23. Inverted-T prestressed bent cap (Source: Billington et al. 1999).....	153
Figure 5-24. Precast bent cap with cavities (Source: Culmo 2009).....	154
Figure 5-25. Bent cap configurations.....	155
Figure 5-26. Precast segmental column (Source: Billington et al. 2001; Shahawy 2003) .	156
Figure 5-27. Short-span bridge with precast segmental columns (Source: Shahawy 2003)	157
Figure 5-28. Diamond shaped transverse connection details between panels (Source: Culmo 2009).....	159
Figure 5-29. Transverse connection details of a grouted shear key.....	160
Figure 5-30. Transverse connection detail of a grouted shear key with longitudinal post- tensioning duct coupling.....	160
Figure 5-31. Critical design parameters for longitudinal connection at the deck level	162
Figure 5-32. Standard details for the longitudinal connection at the deck level.....	163
Figure 5-33. Hanging formwork for longitudinal connection at deck level	164
Figure 5-34. Panel to steel girder connection details (Source: Culmo 2009).....	165
Figure 5-35. Panel to concrete girder connection details.....	166
Figure 5-36. Leveling device detail and formwork at the deck level (Source: PCI NE 2011)	167
Figure 5-37. Continuity detail at pier using splice sleeves (Source: Culmo 2009)	168
Figure 5-38. Continuity detail at pier of a steel box girder (Source: Culmo 2009).....	168
Figure 5-39. Continuity detail at pier using link slab (Source: Ulku et al. 2009).....	169
Figure 5-40. Continuity detail at abutment with semi-integral abutment (Source: Aktan and Attanayake 2011).....	170
Figure 5-41. The template used for a column splice with grouted splice coupler	172
Figure 5-42. Precast concrete abutment cap to prestressed concrete pile connection	173
Figure 5-43. Temporary support system for pile cap to pile connection (Source: Wipf et al. 2009a)	174
Figure 5-44. Adjustable friction collar fixed to the octagonal column to temporarily support abutment cap or pier cap (Source: www.proscaffna.com)	174

Figure 5-45. Octagonal precast column to footing connection with grouted duct or splice sleeve and socket connection.....	175
Figure 5-46. Circular precast column to footing connection with grouted void/pocket and shear key	176
Figure 5-47. Column to footing connection with beveled void corners (Source: Photo courtesy of MDOT)	176
Figure 5-48. Precast concrete abutment to precast concrete footing	177
Figure 5-49. Precast bent cap to precast column connection details with grouted pocket and two layers of reinforcement (Source: Restrepo et al. 2011)	178
Figure 5-50. Grouted corrugated duct connection for precast bent cap to precast concrete column	179
Figure 5-51. Vertical splice duct connection for precast bent cap to precast concrete columns (Source: Culmo 2009).....	180
Figure 5-52. Grouted shear key and reinforced concrete connection details.....	181
Figure 5-53. Abutment stem splice connection details	182
Figure 5-54. Bent cap connection details.....	182
Figure 5-55. Column splice with grouted splice coupler (Source: Culmo 2009).....	183
Figure 5-56. Vertical connection of precast pier element (Source: Culmo 2009)	184
Figure 5-57. Elevation of the pier	185
Figure 5-58. Plan view of the footing	186
Figure 5-59. Column to footing connection.....	186
Figure 5-60. Saw cutting technique	192
Figure 5-61. Hydrodemolition technique.....	192
Figure 5-62. Demolition by hammer and pulverizer	192
Figure 5-63. Removal of a box-beam	194
Figure 5-64. Deconstruction hierarchy of the recommended bridge systems	194
Figure 5-65. Removal of safety barriers	195
Figure 5-66. Replacement of deck panels (Source: Wenzlick 2005).....	196
Figure 5-67. Demolition of a bent cap and columns as a single unit (Source: SCDOT)....	198
Figure 5-68. Column and pier walls are sawn off and lifted out for demolition (Source: http://www.mcgee-engineering.com)	199

Intentionally left blank

1 INTRODUCTION

1.1 OVERVIEW

Michigan has eleven corridors of National/International significance. The decision principles to guide the management, operation, and investments on these corridors include strategies to reduce delays and minimize construction impacts. MDOT's vision for transportation states that, "*MDOT will embrace technology and technological development. The department will use innovation in every aspect of what it builds, how it builds, and in every service that is provided.*" In order to minimize the impact of construction on the traveling public, MDOT utilizes innovative and specialized construction methods such as ABC (MDOT 2007). The first such implementation of *Accelerated Bridge Construction* was in 2008 by the construction of Michigan's first totally prefabricated full-depth deck panel bridge system, the Parkview Avenue bridge. The bridge carries Parkview Avenue over US-131 freeway. MDOT has completed few more ABC projects since then.

The National Bridge Inventory (NBI) of 2008 showed that there are 4,716 bridges (exceeding the span of 20ft) maintained by the Michigan Department of Transportation (MDOT) on the national highway system, and among those the percentage of structurally deficient bridges is about 14% (Juntunen 2008). The requirement of rehabilitation and repair with conventional approaches creates delays and safety conditions for the commuters. This can be affirmed by the 2010 road construction work zone crash statistics from the State of Michigan, which documented 5632 crashes, 1488 injuries, and 23 driver and/or passenger fatalities in highway work zones in 2010. According to AASHTO (2011) there was an increase of 500 crashes and 100 injuries from 2009 to 2010. The work zone safety guidelines provided by the Transportation Information Center (TIC) suggests making traffic safety, project duration, and construction quality an integral and high priority factor of every project (TIC 2006).

Michigan, like other highway agencies in the region, has several challenges in specifying prefabricated bridge elements and systems (PBES) and accelerated bridge construction (ABC) techniques for bridge replacement projects. These are highlighted in the Mid-North Regional Peer-to-Peer Exchange Final Report (FHWA 2012). Among those (1) justification of initial project costs, (2) defining a rational process for selecting ABC over conventional construction,

(3) absence of PBES selection guidelines and proven standard and successful designs, (4) absence of constructability evaluation guidelines, and (5) questionable durability performance of PBES and connections are identified as the most commonly raised issues.

Considering the current and future needs of the state as well as the local agency needs, MDOT initiated this project with the objective of identifying and documenting national and international best practices on accelerated bridge construction and deconstruction, identifying precast system configurations with attention to constructability, maintainability, repairability, and durability, and developing short-term and long-term plans for technology implementation.

1.2 PROJECT OBJECTIVES AND TASKS

This project is designed for documenting current national and international state-of-the-art practices in prefabricated bridge elements and systems design, construction, and demolition, and associated potentials and limitations. The process is to analyze the existing practices and systems and then to identify fully prefabricated precast concrete systems suitable for Michigan. The specific objectives of the study are as follows:

- (1) Develop a comprehensive list of prefabricated bridge elements and systems (PBES) and associated potentials and limitations with attention to durability, repairability, and maintainability.
- (2) Develop a Michigan specific decision-making platform.
- (3) Evaluate performance of selected PBES bridges.
- (4) Develop a comprehensive list of connection details and cementitious materials for durable connections and closures suitable for Michigan exposure conditions.
- (5) Develop standard deck level longitudinal connection details for unremarkable bridges.
- (6) Document construction procedures, equipment, and implementation limitations; and develop recommendations for deconstruction of selected PBES bridges.
- (7) Provide recommendations for further research and implementation of selected systems.

To achieve these objectives, this project was organized into six tasks: (1) review the state-of-the-art literature, (2) assess the performance, challenges and lessons learned, (3) develop a Michigan specific ABC decision-making platform, (4) recommend PBES, connection details, and cementitious grout or closure material suitable for Michigan, and deconstruction procedures for selected PBES bridges, (5) develop standard details for deck level longitudinal

connection of decked bulb-tee and decked box-beams, and (6) provide recommendations for further research and ABC implementation.

1.3 REPORT ORGANIZATION

The report is organized into 8 chapters.

Chapter 2, the state-of-the-art literature review describes potentials and limitations of PBES, connection details between prefabricated elements, properties of cementitious grouts and special mixes and their application procedures, and accelerated construction and deconstruction technologies. Further, constructability evaluation benefits, implementation challenges, and elements of a constructability program are discussed. The state-of-the-art decision-making models/frameworks and their associated limitations are reviewed with respect to cast-in-place (CIP) and ABC methods.

Chapter 3 presents challenges and lessons learned from earlier ABC implementations and performance of in-service ABC bridges.

Chapter 4 describes the Michigan specific ABC decision-making platform.

Chapter 5 describes PBES, connection details, and grout and special mixes for Michigan exposure conditions. The potential construction/deconstruction methods and equipment, and implementation challenges associated with the PBES are also presented.

Chapter 6 presents constructability review checklist that includes questionnaire developed through synthesizing the benefits, challenges, and essential elements of a constructability program.

Chapter 7 presents the comprehensive results, recommendations, and proposed further work on this topic.

Chapter 8 includes the cited references.

Intentionally left blank

2 STATE-OF-THE-ART LITERATURE REVIEW

2.1 OVERVIEW

2.1.1 ABC/ABR Definition

Accelerated Bridge Construction (ABC) is a project delivery process which minimizes on-site construction duration. ABC alleviates congestion, reduces environmental impacts, and improves safety. The on-site construction duration is reduced through several processes. Currently popular processes are (a) assembling the prefabricated bridge structural elements into place, (b) moving a bridge superstructure or a complete bridge from within right-of-way into place and (c) constructing ‘Replacement Bridge’ on temporary supports adjacent to the bridge and sliding in place following rapid demolition. The use of the latter two processes in a project is defined as Accelerated Bridge Replacement (ABR). Unless there is a specific need, in this chapter, both operations (ABC and ABR) are referred as ABC.

2.1.2 Objective and Approach

The literature review is conducted to identify, review, and synthesize information related to accelerated bridge construction. Concentration areas for the literature review are as follows:

- Prefabricated bridge configurations/elements/systems currently being used in ABC or the elements/systems that show a potential (These include prefabricated superstructure and substructure elements.),
- Connection (joint) details between prefabricated elements or systems,
- Cementitious grout or special concrete mixes and application procedures specified for the prefabricated element connections,
- Accelerated bridge construction and deconstruction methods and equipment,
- Constructability analysis benefits, implementation challenges, and essential elements of a constructability program, and
- State-of-the-art decision making models.

2.2 PREFABRICATED BRIDGE ELEMENTS AND SYSTEMS

2.2.1 Introduction

Prefabricated elements and systems are being used to minimize on-site bridge construction duration. In the meantime, innovative details and construction procedures are being developed. The literature presents cross-section details and span lengths of elements and systems as well as construction details. However, there is no comprehensive discussion on the benefits and limitations of these elements and/or systems in terms of span length, underclearance, durability, and repairability. Hence, this section of the report is developed with the following objectives:

1. Document the available prefabricated bridge elements and systems (PBES).
2. Discuss the benefits and limitations of each PBES used in bridge superstructures, and commonly used span ranges to facilitate selection of such elements or systems for a specific site.
3. Document the concrete mix designs to achieve the required strengths for specific spans.

In PBES, the bridge superstructure typically consists of (1) prefabricated girders and a cast-in-place concrete deck, or (2) prefabricated girders and precast deck panels with or without cast-in-place concrete deck, or (3) modular systems (e.g., single-tee, double-tee, segmental box girders, or (4) any other configuration where a continuous bridge superstructure is formed once the prefabricated elements are placed and connected through field cast joints. The prefabricated bridge substructure units typically consist of foundations (piles or footings), pile caps, columns, bent caps (or pier caps), abutments, and backwalls (RTA 2004). According to RTA (2004), widely recognized classifications of the bridge span ranges are these:

- Short-span: 20 ft to 60 ft,
- Short-to-medium span: more than 60 ft up to 130 ft,
- Medium span: more than 130 ft up to 260 ft,
- Medium-to-long span: more than 260 ft up to 980 ft, and
- Long span: more than 980 ft up to 2,600 ft.

The maximum span length of the standard prefabricated girder sections is given in the PCI Bridge Design Manual (PCI 2011) and the DOT documents (MDOT-BDM 2013; UDOT 2010b). The suitable standard sections for the required span can be identified from these

manuals. However, not only the span limitations, the weight of prefabricated elements for transport and placement is a consideration. FHWA (2012) lists the transport weight and size limitations as one of the major concerns raised by the DOTs during regional peer-to-peer exchanges. The weight issue is addressed in the MDOT-BDM (2013) Section 7.01.19, recommending a limiting weights of prefabricated bridge element (PBE) to 80 kips (40 tons) for safe handling using conventional equipment. The ABC Toolkit developed under the SHRP2 R04 project (SHRP2 2012) on the other hand, recommends limiting weights to 160 kips (80 tons). Where site conditions allow, SHRP2 (2012) suggests using PBE up to 250 kips (125 tons). Increased weight limits allow building longer spans and wider bridges to further reduce construction duration. Initially, the weight limits were raised to accommodate the substructure components. However, weight limits need to be reviewed following selecting the girder types because the girder weights may exceed the limits specified for the substructure components. As shown in Table 2-1, the majority of girder spans are limited with the 80 kip weight limit.

Table 2-1. Girder Types and Span Length with 80 kips Weight Limit

Girder Type		Weight (kip/ft)	Standard Section Maximum Span (ft)*	Span Length with 80 kips Weight Limit (ft)**
PCI Decked Bulb-Tee with 6 in. thick flange	DBT-35	1.07	85	75
	DBT-53	1.19	135	67
	DBT-65	1.27	165	63
PCI Decked Bulb-Tee with 9.5 in. thick flange	DBT-35	1.42	<i>Not defined</i>	56
	DBT-53	1.54	<i>Not defined</i>	52
	DBT-65	1.62	<i>Not defined</i>	49
Decked PCI Box-Beam (48 in. wide) with 9.5 in. thick flange	BI	1.67	<i>Not defined</i>	48
	BII	1.73	<i>Not defined</i>	46
	BIII	1.80	<i>Not defined</i>	45
	BIV	1.83	<i>Not defined</i>	44
PCI Spread Box-Beam (48 in. wide)	BI	0.72	75	75
	BII	0.78	85	85
	BIII	0.85	95	95
	BIV	0.88	100	91
PCI I Beam	I	0.29	40	40
	II	0.38	65	65
	III	0.58	90	90
	IV	0.82	125	97
	V	1.06	140	76
	VI	1.13	150	71
PCI Bulb-Tees	BT-54	0.69	115	115
	BT-63	0.74	130	108
	BT-72	0.80	145	100
MI 1800		0.91	145	88
* Maximum span length is not defined for nonstandard sections				
** Highlighted cells indicate when the component weight limits the usable span				

In 1949, precast concrete girders were introduced to the U.S. during the construction of the Walnut Lane Memorial Bridge in Philadelphia, Pennsylvania (PCI 1976). Prestressed concrete single cell and multi-cell box-beams, which are used in the side-by-side box-beam bridge, are one of the first generation prefabricated girders used in short-span (20 ft to 60 ft) bridges. Use of prestressed concrete box-beams in Michigan bridges dates back to 1955 (Attanayake 2006). Precast concrete I-girders were later developed in 1956 for spans ranging from 24 ft to 70 ft (PCI 1976).

The use of precast concrete bridge deck panels dates back to early 1970's (Issa et al. 1995a). During the mid 1970's, the prestressed bridge deck panels were implemented in Illinois, Texas, Florida, Virginia, and Pennsylvania. Most of the precast bridge deck panels used in that era was neither prestressed nor post-tensioned. The details used at that time for connecting deck panels to the girders were not able to provide monolithic behavior of the deck-girder integrated section. Further, the details used at that time were not adequate to accommodate skew and deck crown (PCI 1976).

Another example of a prefabricated section is the modular superstructure element where girder and the deck are prefabricated as a single monolithic unit. The double-tee section, which was designed for spans from 25 ft to 65 ft, is one of the first generation prefabricated modular elements. Other sections used during the 1970's were channel sections and tri-tee sections. The channel sections were designed for spans from 24 ft to 44 ft and tri-tee sections from 25ft to 40ft. These sections were specified for buildings and parking structures, and subsequently used in bridges with low traffic volume in the U.S. (PCI 1976).

In April 2004, Ralls et al. (2005) conducted a scanning tour covering five countries under the sponsorship of the Federal Highway Administration (FHWA) and the American Association of State Highway and Transportation Officials (AASHTO). The purpose was to study precast structural elements that can be utilized in ABC. Moreover, for the substructure elements, various researchers and U.S. state departments of transportation (DOTs) developed configurations which could be prefabricated and transported to the site to accelerate the substructure construction (Stamnas and Whittimore 2005). Further, new sections for modular

superstructure elements were developed to accelerate the onsite bridge construction process (Graybeal 2009).

PBES, as well as the bridges built using such elements or systems, are presumed to be durable. Unfortunately, data presented in literature is not encouraging. The durability problems are due to the quality of the prefabricated elements, defects during fabrication and erection, details and materials used for connecting prefabricated elements, and construction quality (Issa et al. 1995a; Aktan et al. 2002; Attanayake 2006; Culmo 2010). The overall performance of the bridges that are built using prefabricated elements and/or systems is discussed in Chapter 3. Chapter 2 of the report presents element specific durability problems and benefits and limitations for implementation. To promote successful implementation of PBES, compiling a library of elements and systems for designers to select from based on site-specific parameters is essential. In the element library, including information on benefits and limitations for implementation is desired for planning, design, constructability review, and scheduling.

The typical cross-section dimensions and span lengths of PBES for ABC are compiled from reviews of bridge plans, also from recent demonstration projects, and input from project engineers directly involved in ABC projects. The PBES are listed under four major groups: girders, decks, modular superstructure elements and systems, and substructure elements (Figure 2–1). The elements and systems, which are listed under the four major groups, are further divided into five categories based on their use in accelerated bridge construction. The use categories are: commonly used, limited use, never used, and used in long span bridges (Figure 2–1). A bridge superstructure with a cast-in-place concrete deck requires extended duration of road closure; hence, it is shown in Figure 2–1 in a separate category. A color coding system defining these categories is also as shown in Figure 2–1. The elements or systems listed under the *limited use* category either have been implemented no more than once or twice or are still under development. After careful analysis of the details and performance records available in literature, benefits and limitations of specifying such elements and systems in ABC projects are summarized. This section only provides a brief discussion of each element or system while the details are provided in Appendix A.

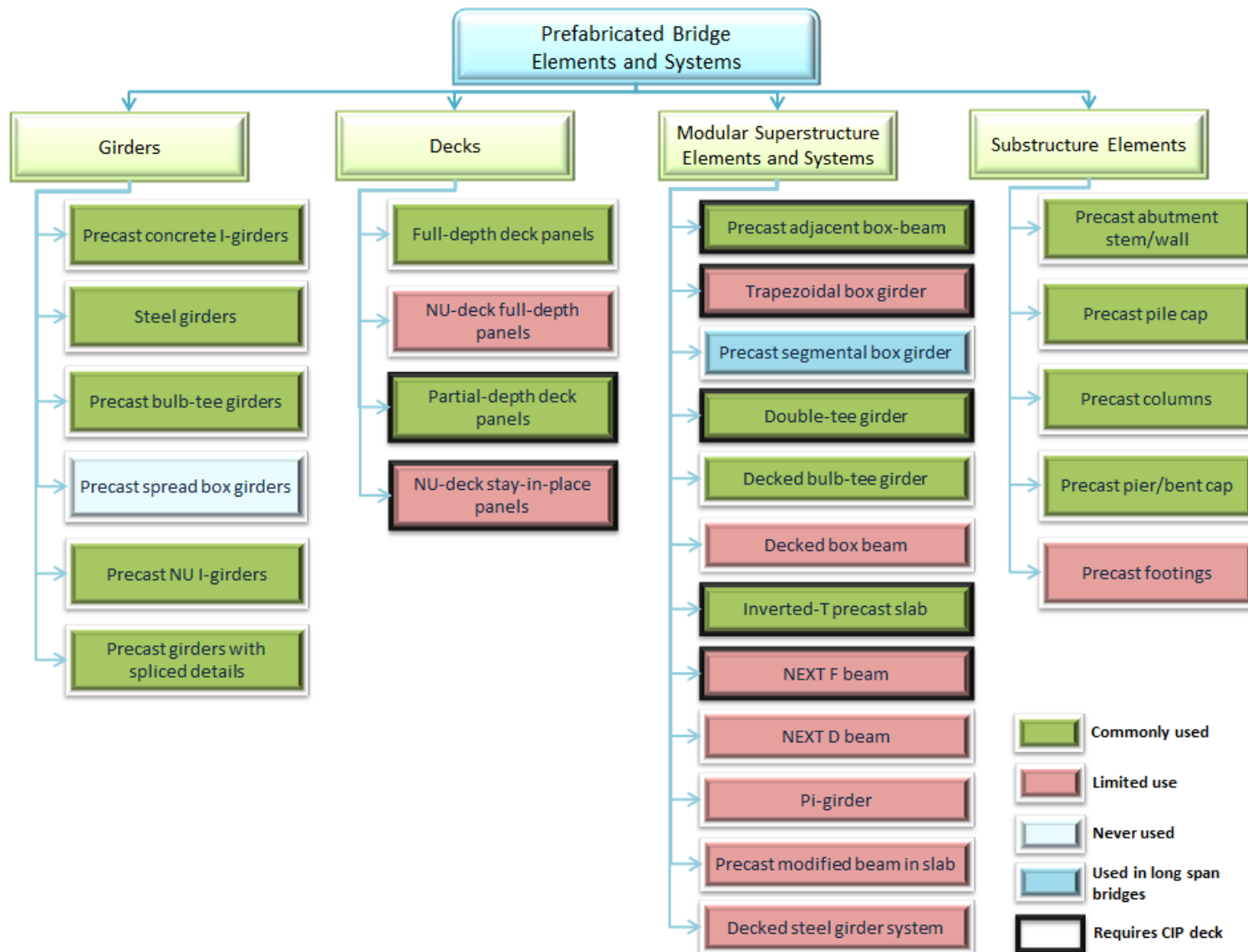

Figure 2–1. Prefabricated bridge elements and systems

2.2.2 Girders

Precast concrete girders are the most commonly specified among all the prefabricated structural elements. Girder types and sections are developed considering span, underclearance, aesthetics, loading (ADT and ADTT), and exposure. Use of these girders in ABC is limited because they can only be combined with partial-depth or full-depth deck panels to qualify for accelerated construction. Though steel girder is listed in Figure 2–1, the discussion is limited because it is possible to design steel girders for most commonly used spans using rolled or built-up sections. On the other hand, prestressed concrete girders require testing and validation when they are different from commonly used sections and spans. Hence, commonly used spans and design strengths are provided with the prestressed girders to help designers specify sections for preliminary design based on site parameters.

Most of the precast girders listed below have been used in vast majority of the projects. A few of them are standardized and the designers, fabricators, and contractors are familiar with the benefits and limitations. The girder types, the projects where they are utilized, information on cross-section dimensions and span lengths, applicable concrete strengths, and benefits and limitations of using the girders are summarized in Appendix A. The girder types reviewed during this study include

1. Precast concrete (PC) I-girders,
2. Steel girders,
3. Precast bulb-tee girders,
4. Precast spread box girders,
5. Precast NU I-girders, and
6. Precast girders with spliced details.

The tables given below (Table 2-2, Table 2-3, and Table 2-4) show the design strength and possible span ranges for standard I-girders, box-beams, girders with spliced span, and bulb-tee girders.

Table 2-2. Standard PC I-Girders, Spread Box Girders, and Girders with Spliced Details (Source: MDOT-BDM 2013; Castrodale and White 2004)

	Depth (in.)	Spans up to (ft)	28-day concrete strength (psi)
PC - I (type I – IV)	28 – 54	~114	5,000 – 7,000
PC – I (Wisconsin type)	70	~120	5,000 – 7,000
PC – I (MI 1800)	70.9	~145	5,000 – 7,000
Spread box-beam (36 in. wide)	42	~95	5,000 – 7,000
Spread box-beam (48 in. wide)	60	~140	5,000 – 7,000
Girders with spliced span	72 – 108	~220	9,000 – 10,000

Table 2-3. Depth and Span Range of Utah Bulb-Tee Girders (Source: UDOT 2010b)

	Depth (in.)	Spans up to (ft)		Diameter of prestressing strands (in.)	Number of strands
		28-day concrete strength of 6,500 psi	28-day concrete strength of 8,500 psi		
Utah bulb-tee girders spaced at 8 ft	42	~85	~98	0.6	N/A
	50	~97	~117		
	58	~112	~131		
	66	~124	~146		
	74	~140	~157		
	82	~150	~167		
	90	~164	~177		
	98	~169	~186		

Table 2-4. Depth and Span Range of NEBT Girders (Source: PCI NE 2011)

	Depth (in.)	Spans up to (ft)	Diameter of prestressing strands (in.)	Number of strands	28 day concrete strength (psi)
NEBT girders spaced at 8 ft	39.4	~85	0.6	60	10,000
	47.2	~98			
	55.1	~111			
	63	~121			
	70.9	~131			

The girders are specified considering span, capacity, efficiency, and benefits/limitations. Most girders are suitable for short and short-to-medium span bridges (up to 130 ft). The girder options are limited for medium span bridges (130 ft to 260 ft). Several efforts have been made to develop girders for medium span bridges (Geren and Tadros 1994). Another option for medium span bridges is girder splicing, which could potentially provide sections for spans up to 220 ft with post-tensioning (Castrodale and White 2004; Chung et al. 2008). Specifically, prestressed I- and bulb-tee girders can be redesigned to incorporate post-tensioning and/or spliced details to accommodate longer spans. Russell et al. (1997) performed a comprehensive study on effect of strand size and spacing on capacity and cost for high strength concrete girders. This study showed that 0.7 in. diameter strands at 2 in. spacing in a bulb-tee girder with 10,000 psi strength provide an economical solution for longer spans.

The NU-I girder series includes depths ranging from 30 in. to 95 in. and constant dimensions for top and bottom flanges, and includes depths for spans up to 300 ft with post-tensioning (Beacham and Derrick 1999). , But the girder web thickness needs to be increased when post-tensioning is used. Reinforcement details are standardized such that the amount of post-tensioning, girder span, or girder spacing does not affect the reinforcement pattern except the spacing (details of NU I-girder reinforcement are presented in Appendix A). Moreover, the large span-to-depth ratio allows for specifying these sections in lieu of steel girders without increasing the superstructure depth (Beacham and Derrick 1999). These girders have been used in many projects and had proven to be durable for continuous spans.

The NU 900 I-girder (35.4 in. deep) is the shallowest section of the series which has been successfully implemented in several projects (Morcoux et al. 2011). In 2009, two non-proprietary Ultra High Performance Concrete (UHPC) mixes were developed by University of Nebraska-Lincoln and designated as NU-UHPC mix #4 and mix #5. A detailed discussion on these mixes is given in Tadros and Morcoux (2009). A new configuration of the NU 900 I-girder was developed with the NU-UHPC mix #5 and 0.7 in. diameter prestressing strands. Research on the NU 900 I-girder verified the implementation with 2 in. strand spacing (Morcoux et al. 2011). NU 900 I-girder spans, number of strands, strand size, and compressive strength of concrete are shown in Table 2-5. The typical NU I-girder series includes a wide range of depths and spans (Table 2-6).

Table 2-5. NU 900 I-Girder Specifications (Source: Morcoux et al. 2011)

	Spans up to (ft)	Diameter of prestressing strands (in.)	Number of strands	Concrete strength at release (psi)
NU 900 I-girder (depth – 35.4 in.)	~90	0.5	60	6,000
	~110	0.6	60	8,500
	~90		36	
	~130	0.7	60	11,000
	~110		38	
	~90		26	

Table 2-6. NU I-Girder Series Specifications (Source: Hanna et al. 2010b)

	Depth (in.)	Spans up to (ft)	Diameter of prestressing strands (in.)	Number of strands	28 day concrete strength (psi)
NU I-girder	94.5	~200	0.6	60	12,000
	78.7	~180			8,000 – 12,000
	70.9	~172			8,000 – 12,000
	63.0	~155			8,000 – 12,000
	53.1	~135			8,000 – 12,000
	43.3	~118			8,000 – 12,000
	35.4	~110			8,000 – 12,000

2.2.3 Decks

Precast full-depth and partial-depth deck panel systems were reviewed. The systems that were reviewed include

1. Full-depth deck panels with transverse prestressing and longitudinal post-tensioning,
2. Full-depth deck panels with only longitudinal post-tensioning,
3. Full-depth deck panels with only transverse prestressing,
4. NU-deck full-depth panels ,
5. Partial-depth deck panels, and
6. NU-deck stay-in-place panels.

Appendix A presents the specifications, benefits, and limitations of each system. The full-depth deck panels with transverse prestressing and longitudinal post-tensioning is the most specified deck panel system currently available for accelerated bridge construction. The primary limitations listed are related to grouting connections and repair and rehabilitation complexities of the post-tensioned system. A large number of grouted connections require

selection of grout with specific durability and bonding properties. Also, grout properties are important in developing solid and tight fit between the components. Further, connection detailing and grout selection, preparation, application, curing and protection needs to be addressed in special provisions (see Section 2.4 for more details on this topic). With regard to limitations on repair and rehabilitation with the post-tensioning, it is best to implement this system at sites where girder damage (e.g., high-load hits) is unlikely. Based on the currently available data, deck panel systems without longitudinal post-tensioning could not fulfill the durability performance expectations. New partial and full-depth deck panel systems have been developed. These are NU-deck panels (1st and 2nd generation – full-depth), the modified NU-deck panel (full-depth), and the NU-deck stay-in-place (SIP) panels. These systems use unprotected prestressing and post-tensioning strands, which will not result in a durable deck assemblage. Considering all the benefits and limitations, full-depth deck panels with transverse prestressing and longitudinal post-tensioning are still the best choice for Michigan bridges where substantial winter maintenance is required.

2.2.4 Modular Superstructure Elements and Systems

Prefabricated elements that are placed side-by-side to form a bridge superstructure and connected by shear and/or flexure-shear transfer details are referred to as modular superstructure elements. Examples are single-cell rectangular box-beams specified in adjacent box-beam bridges, trapezoidal box girders, single-cell or multi-cell sections for segmental box girder bridges, tee-beams, double-tee girders, and deck integrated sections, such as the decked single-cell rectangular box-beam developed for the M-25 Bridge over the White River in Michigan.

Prefabricated modular systems, such as the INVERSESET™ and decked steel girder system, are developed by combining multiple girders and a precast slab. The decked steel girder system design standards and design examples are provided in the SHRP 2 Project R04 publications (SHRP2 2012). The decked steel girder system has been used in the I-93 Fast 14 project in Medford, MA (MassDOT 2011), and the Keg Creek bridge replacement project in Pottawattamie County, IA (IowaDOT 2011).

Information related to prefabricated elements and systems are presented in Appendix A. Sometimes, both prefabricated elements and systems are referred to as modules. The information summarized in the appendix includes the projects where these elements or systems were implemented, along with the attributes, benefits, and limitations of each modular element or system.

The *prefabricated modular superstructure elements* reviewed during this project include

1. Precast adjacent box-beam,
2. Trapezoidal box girder,
3. Precast segmental box girder,
4. Double-tee girder,
5. Decked bulb-tee girder,
6. Decked box-beam,
7. Inverted-T precast slab,
8. NEXT F beam,
9. NEXT D beam,
10. Pi-girder, and
11. Precast modified beam in slab.

The *prefabricated modular systems* reviewed during this project include

1. The INVERSET™ system, and
2. The decked steel girder system.

The modular superstructure elements and systems, except the segmental box-beam section, are suitable for short-span bridges (i.e., 20 ft to 60 ft) and *up to* short-to-medium span bridges (i.e., 60 ft to 130 ft).

2.2.4.1 Precast Adjacent Box-Beam

Adjacent box-beam bridges have been designed and constructed very efficiently since the mid 1950s. This system has been implemented with and without a cast-in-place concrete deck. The longitudinal cracking at the surface reflecting from the beam joints prompted the inclusion of a 6 in. thick cast-in-place deck and increased transverse post-tensioning. However, reflective deck cracking persisted. Also, inspection of concealed girder faces is still a

challenge. The adjacent box-beam depth range, span, and compressive strength of concrete used in Michigan are shown in Table 2-7 (MDOT-BDM 2013).

Table 2-7. Attributes of Adjacent Box-beams (Source: MDOT-BDM 2013)

	Depth range (in.)	Spans up to (ft)	28 day concrete strength (psi)
Box-beam (36 in. wide)	17 – 42	~120	5,000 – 7,000
Box-beam (48 in. wide)	21 – 60	~150	5,000 – 7,000

2.2.4.2 Trapezoidal Box Girder

The trapezoidal box girder was developed in 1998 for bridges up to short-to-medium spans. The girder was developed in two cross-sections: (1) a closed trapezoidal box and (2) an open section requiring a cast-in-place concrete deck. Considering the difficulty in the casting of a closed trapezoidal box section, an open-top was preferred (Badie et al. 1999). The attributes of an open-top trapezoidal box girder are shown in Table 2-8. Based on the data currently available, this particular section has not been specified for any project.

Table 2-8. Attributes of Trapezoidal Box Girders (Source: Badie et al. 1999)

	Depth range (in.)	Spans up to (ft)	28 day concrete strength (psi)
Trapezoidal box (totally closed)	23.5 – 31.5	~95	7,500
Trapezoidal box (open-top)	20 – 28	~86	9,000

2.2.4.3 Double-Tee and Decked Bulb-Tee Girders

The standard double-tee girder system has been available for many decades. This system was originally developed for building and parking structure floor systems. Web thickness is the limiting factor in prestressed girder design. Further, developing a moment connection detail at the flange with two layers of reinforcement is difficult due to limited flange thickness. Standard double-tee sections require a cast-in-place concrete deck. Hence, the use of these girders is limited to short-span bridges with low-traffic volume.

Due to the documented limitations of the standard double-tee girders, decked bulb-tee sections were developed. Increased web thickness of decked bulb-tee sections accommodates post-tensioning to develop continuity details over the supports. This system is suitable for bridges up to short-to-medium span. As with any system, durability performance is a concern. The increased flange thickness of decked bulb-tee section is suitable for developing durable flexure-shear transfer connection details.

2.2.4.4 Inverted-T Precast Slab

Inverted-T precast slab, which also provides a platform for the construction and formwork for the cast-in-place concrete deck, is suitable for short-span bridges with underclearance issues. The limitation of this system is the time required to construct the cast-in-place concrete deck. The deck requires 7-day wet curing and extends the project duration. It is not recommended for locations with high traffic volume or long detour. Further, reflective deck cracking is a concern similar to adjacent box-beam bridge decks.

A recent NCHRP project (French et al. 2011) investigated three aspects of the inverted-T precast slab: (1) stresses in the end zones of the precast section, (2) transverse reinforcement spacing at the connection, and (3) compatibility with AASHTO (2010) design specifications. The project concluded that AASHTO (2010) design specifications are not conservative for deep inverted-T sections (i.e., depth greater than 22in.), because more reinforcement is required than specified. NCHRP project (French et al. 2011) developed a design guide for the inverted-T precast slab. However, the section with the incorporated new details has not been specified yet, so that the reflective cracking can be assessed.

2.2.4.5 NEXT Beam

The NEXT F beam system requires an 8 in. thick cast-in-place concrete deck on the typical 4.5 in. thick flange. Both the NEXT F and D beams are suitable for short and up to short-to-medium span bridges with a cast-in-place deck. As with any prefabricated system, joint durability is a concern. However, the use of flexure-shear transfer connections may improve joint durability. These connections need further investigation.

2.2.4.6 *Pi-Girder*

The pi-girder is a shallow section with a thin deck. At the current state of practice, this system is costly with the use of proprietary materials and requiring special forms for casting.

2.2.4.7 *Precast Modified Beam in Slab System*

The precast modified beam in slab system has steel girders embedded in concrete to protect against corrosion. This system is suitable for short-span bridges in corrosive environments. Durability performance of the longitudinal joints needs to be investigated.

2.2.4.8 *Decked Steel Girder System*

The proprietary INVERSESET™ system is designed for short and short-to-medium span bridges in non-corrosive environments. Even though the system is costlier than other systems, the specific manufacturing process precompresses the deck which helps eliminate/reduce deck cracking. However, replacement or overlays to a precompressed deck is a challenge.

The non-proprietary decked steel girder module that was developed under the SHRP2 Project R04 (SHRP2 2012) utilizes conventional designs and manufacturing processes. Therefore, this system could be economically specified for short and short-to-medium span bridges in non-corrosive environments. The *weathering steel* could be utilized to address the corrosion issue. *Weathering steel* has chemical compounds which enable the surface to create a protective layer by weathering. This protective layer, if retained, reduces the progression of corrosion (CCI 2004). Yet low-rate steel corrosion is present (Tozier Ltd. 2011). *Weathering steel* is not corrosion proof; and if deicing salts are allowed to accumulate, the corrosion rate sharply increases. In salt laden environments, the protective layer may not stabilize and corrosion can progress more rapidly (Tozier Ltd. 2011). In zones with deicing usage, *weathering steel* is not suitable, and steel must be protected using high-quality paint.

2.2.4.9 *Summary*

In summary, the bridge superstructures using trapezoidal box, double-tee, inverted-T, or NEXT F beams require a cast-in-place concrete deck; hence project duration is extended. Generally, cast-in-place concrete decks require 7-day wet curing.

Rectangular box-beams for adjacent box-beam bridges, decked bulb-tee beams, NEXT D beams, Pi-girders, INVERSESET™, and decked steel girder systems do not require cast-in-place deck. Therefore, on these elements or systems, for the wearing surface a hot-mix asphalt (HMA) layer with a waterproofing membrane, epoxy overlay, or latex modified concrete overlay is considered by many states. There have been records of poor HMA overlay performance which requires further investigation. Adequately designed flexure-shear transfer details need to be implemented for improved durability. Suitable grout material is needed to prevent cracking or debonding at the interfaces. The majority of these elements or systems were specified in several projects, and performance data may be available with respective DOTs.

2.2.5 Substructure Elements

Widely used prefabricated substructure elements are precast pier caps and bent caps (Ralls et al. 2004). Following the charge by the Technology Implementation Group (TIG) of AASHTO to promote further development of PBES, precast columns, precast segmental abutment stems, and precast pile caps were developed and implemented in several projects. Highway agencies in the U.S. designed and constructed innovative structural systems along with conducting research to standardize these substructure elements for high traffic-volume bridges (Matsumoto et al. 2001; Billington et al. 2001; Ralls et al. 2004; Restrepo et al. 2011). A summary of properties, benefits, and limitations of these prefabricated substructure elements is given in Appendix A. A majority of the prefabricated substructure elements, which were specified in ABC projects, are not standardized. A complete set of prefabricated substructure elements, as listed below, are available and can be specified for projects with changes to fit the project requirements. Based on the site constraints and cost, alternatives can be selected for a particular application.

The prefabricated substructure elements discussed in Appendix A include

1. Precast abutment stem/wall,
2. Precast pile cap,
3. Precast columns,
4. Precast segmental columns,
5. Precast pier/bent cap, and
6. Precast footings.

A detailed discussion of each of these elements is provided in Appendix A. Benefits and limitations of selected elements are provided in Chapter 5.

2.2.5.1 Reduced-Weight Bent/Pier Cap

As discussed in Section 2.2.1, the weight of prefabricated elements for transport and placement is a limitation. Generally, substructure elements are heavier than the superstructure elements. A bent cap is one such element that created many challenges during placement (Attanayake et al. 2012). Various bent and pier cap configurations and details are implemented to reduce the weight (Culmo 2009; Restrepo et al. 2011; Billington et al. 1999; Klaiber et al. 2009). The details of each of these elements are provided in Appendix A. The reduced-weight configurations presented in Appendix A include

1. Inverted U-section (Culmo 2009),
2. Precast reinforced bent cap with cavities (Culmo 2009),
3. Tapered cantilever section (Restrepo et al. 2011),
4. Precast inverted T-section (Billington et al. 1999),
5. Steel-concrete composite section (Klaiber et al. 2009), and
6. Precast segmental columns with precast templates (Billington et al. 1999).

Benefits and limitations of these selected elements are provided in Chapter 5.

2.2.6 Miscellaneous

2.2.6.1 Accelerated Bridge Replacement (ABR) Technologies

Construction technologies used in ABR such as SPMT and slide-in are presented in Appendix A. A list of attributes, limitations, and details of the selected projects where these technologies are specified is also presented.

2.2.6.2 High Performance Concrete

High performance concrete has been specified and used in ABC projects. Mix designs, documented strengths, and other mix parameters are given in Appendix A. As with any other materials, prior to specifying their use, trial mixes and performance testing should be required to evaluate the material for the specific application. Additionally, documenting challenges and lessons learned during mixing, transporting, placing, handling, and curing will be helpful.

2.3 CONNECTION DETAILS

Prefabricated bridge elements and systems are discussed in Section 2.2. Even though elements and systems are prefabricated, continuity and the load transfer mechanisms are established by field cast connections. The connections are categorized as superstructure and substructure connections (Figure 2–2). Superstructure connections are further classified as deck level transverse, deck level longitudinal, deck to girder, continuity details over pier or bent, and continuity details at abutment. The substructure connections are further classified into pile cap or abutment to pile, abutment wall to footing, column to footing, pier or bent cap to column, vertical connection between elements, and segmental columns or piers. The details under each category are provided in Appendix B.

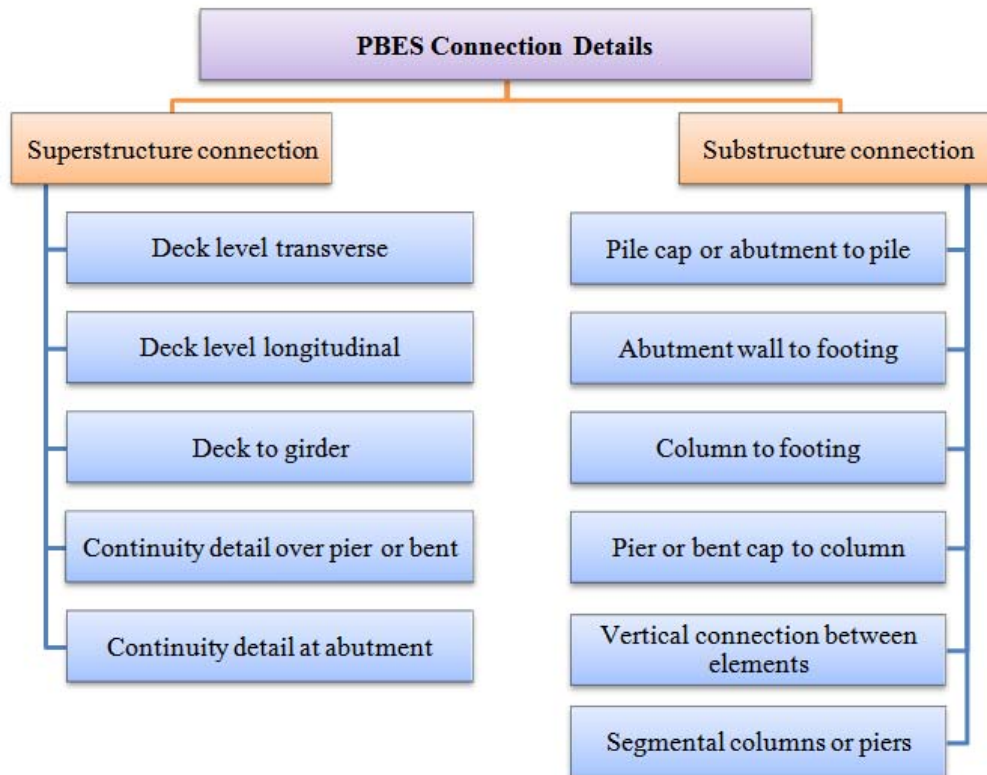

Figure 2–2. Classification of prefabricated element connection details

The durability performance of PBES is a critical consideration. The PBES durability is primarily controlled by the performance of field cast connections. In order to assure durability under the exposure conditions of Michigan, transverse and longitudinal connections of bridge superstructures and other connections used in bridge substructures are required to transfer

moment and shear as well as tension, compression and torsion. Crack width limitations would be the means of quantifying durability in the ABC design process.

The post-tensioning or specific details used for connecting substructure elements in regions with high seismic activities are not included in Appendix B. The additional information presented in the Appendix includes review comments and projects where the specific details are implemented.

Durability performance of ABC methodologies that are currently being implemented were reviewed and presented in Chapter 3. In addition to the exposure conditions, other factors that need to be considered are (1) load transfer mechanism, (2) constructability, and (3) connection dimensions and tolerances (to ensure construction quality).

The connection details presented in Appendix B are reviewed considering load transfer mechanism, constructability, and durability. The most suitable details for implementation in Michigan are presented in Chapter 5.

2.3.1 Load Transfer Mechanism

Connections often require to transfer moment, shear, tension, compression, and torsion. Longitudinal and transverse connections that can accommodate moment and shear transfer under all loading conditions are recommended for Michigan. A typical flexure-shear transfer connection can be developed with two layers of reinforcement (French et al. 2011). However, unreinforced joints can also be designed to transmit moment and shear with appropriate post-tensioning design.

2.3.2 Constructability

Constructability is a critical aspect that needs special attention when selecting connection details. Inadequate details that lead to constructability issues compromise durability as well increase or delay the project schedule. Constructability is a broad topic, and a detailed discussion is provided in Section 2.6. However, constructability issues related to connection details are also discussed within this chapter, where applicable. Potential constructability issues need to be identified during design. In that regard, issues related to constructability also need to be documented in post-construction reports for assuring continuous improvement.

2.3.3 Connection Dimensions and Tolerances

Adequate space needs to be provided for field welding, coupling post-tension tendons, placing necessary rebars, and grouting. In addition, component tolerances need to be specified to avoid any unaccounted load transfer through a connection. As an example, Figure 2–3a shows a typical transverse connection detail of a full-depth deck panel system that allows the panels to be placed against each other (a tolerance of $\frac{1}{4}$ in. \pm $\frac{1}{4}$ in. can result in zero gap between the panels as shown in Figure 2–3b). Hence, the grout is not compressed, and the load is transferred through contact points of the panels under post-tensioning, causing splitting cracks.

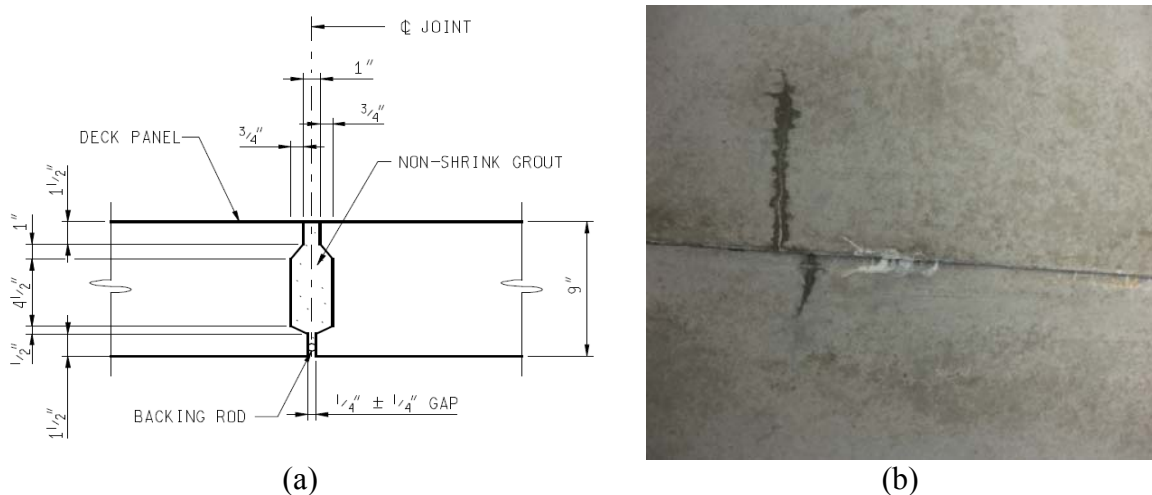

Figure 2–3. (a) Typical transverse connection detail of a full-depth deck panel system, and (b) zero tolerance leading to cracking at panels after post-tensioning

The connection needs to be adequately detailed to assure construction quality. When other alternatives are available, the connections with confined space, narrow access, and sharp corners or edges need to be avoided to minimize potential for developing voids during grouting. When a confined grouted pocket is to be filled, a proper air vent system is necessary. Connections with large cavities cannot be filled with neat grouts and require extended grouts or special mixes. However, slow strength development of extended grouts and other special mixes may slow the construction. Additionally, fit issues with connection reinforcement are reported, and those required field bending to make the components fit (Figure 2–4). Field bending is not desirable and can also damage epoxy coating.

The process of specifying material for the grout pockets, application procedures, and ensuring quality of grouted connections are discussed in Section 2.4. To assure the quality of field cast

connections, component tolerances and cavity dimensions need to be designed considering the dimensional growth that may limit the space provided for adjacent component placement, specifying grout or special mixes at connections, material application procedures, constructability, project schedule, and construction quality assurance.



Figure 2–4. Field bending of reinforcement to overcome space issues (Source: <http://www.flickr.com/photos/iowadot>)

2.4 GROUT MATERIALS FOR CONNECTIONS AND APPLICATION PROCEDURES

2.4.1 Review Objective

The objective of this review is to develop a library of grout and special mixes that are suitable for precast concrete component connections. Connection examples are; shear keys, transverse connections, and haunches, column to footing, and pile and abutment stem. Grout types and properties are compiled from the manufacturer data sheets and available laboratory or field test data are presented for comparison purposes. Further, special mixes discussed in literature are summarized. The properties considered in this study are as follows:

- Compressive strength at 1, 3, 7, 28 days,
- Freeze/thaw resistance,
- Non-shrink properties (Change in height/volume as per ASTM C1090),
- Initial setting time,
- Grout pocket dimensions,
- Working temperature range,
- Site constraints and limitations, and
- Curing requirements.

2.4.2 Commercially Available Grouts

List of commercially available grouts and associated properties are presented in Table 2-9 and Table 2-10.

Table 2-9. Summary of Commercial Grout Properties

		Set 45 ⁺	EUCO SPEED MP*	SS Mortar	Masterflow 928	747 Rapid Setting Grout	S Grout	SonogROUT 10k	SikaGrout 212	Five Star Grout	Construction Grout
Compressive strength (ksi) (min. 5.0 ksi @ 24 hrs. as per AASHTO 2010)	1 day	6.0	6.0	4.0	4.0	7.6	3.5	1.6	3.5	4.0	1.5
	3 days	7.0	6.5	5.4	5.0	8.2	5.0	3.8	-	5.5	5.0
	7 days	-	7.0	7.0	6.7	10.6	6.0	5.1	5.7	6.5	6.0
	28 days	8.5	7.5	11.0	8.0	12.6	8.0	6.2	6.2	8.0	7.0
Initial setting time (min)		15	12	30	3 hrs	26	45	3 hrs	5 hrs	45	6 hrs
Fill depth/thickness for neat grout (in.)	Min	0.5	0.5	-	1	-	-	0.5	0.5	1	-
	Max	2	1	-	6	2	2	2	2	6	-
Working temperature (°F)	Min	-	-	50	45	40	40	65	45	40	50
	Max	85	85	90	90	85	85	75	70	90	90
Freeze/thaw resistant		YES	YES	-	YES	-	YES	YES	YES	-	-
Change in Height/Volume (as per ASTM C1090)											
	28 days	-	-	-	0.06%	-	-	0.04%	0.03%	0.30%	0.08%
Extend with aggregate		-	YES	-	YES	YES	YES	YES	YES	YES	YES

* EUCO SPEED MP HW shall be used for temperature above 85 °F and the properties are same as the EUCO SPEED MP

+ SET 45 HW shall be used for temperature above 85 °F and the properties are same as the SET 45. SET 45 HW can be extended with aggregates for larger fill depth.

Table 2-10. Summary of Commercial Grout Properties

		Sure-Grip	Speccrete Superb Grout 611	CRYSTEX	1107 Advantage Grout	Conspec 100	DURAGROUT	Enduro 50	Multi-Purpose Grout	PRO GROUT 90	Quickrete Non-shrink Precision Grout	Meadows Sealtight 588-10K
Compressive strength (ksi) (min. 5.0 ksi at 24 hrs. as per AASHTO 2010)	1 day	5.0	5.0	4.6	2.5	3.8	2.3	-	2.1	4.7	3.0	4.5
	3 days	-	7.0	6.5	5.0	5.4	-	4.5	4.6	5.6	9.0	5.5
	7 days	8.0	8.5	8.2	6.0	7.7	7.0	5.8	6.7	6.6	9.5	6.5
	28 days	10.0	11.0	10.2	8.0	8.4	8.3	8.0	9.3	7.8	12.5	9.2
Initial setting time (min)		30	70	60	30	35	30	-	4 hrs	4 hrs	25	3 hrs
Fill depth/thickness for neat grout (in.)	Min	-	-	-	-	-	-	-	-	-	-	-
	Max	3	2	4	3	3	-	3	3	-	-	-
Working temperature (°F)	Min	45	45	45	45	40	40	40	45	-	50	-
	Max	90	70	-	90	-	-	-	90	-	90	-
Freeze/thaw resistant		-	-	-	-	-	-	-	-	YES	-	-
Change in Height/Volume (as per ASTM C1090)	28 days	-	0.03%	0.02%	-	0.03%	0.03%	0.03%	0.13%	-	0.20%	0.14%
Extend with aggregate		YES	YES	YES	YES	YES	YES	YES	YES	-	-	YES

2.4.2.1 Compressive Strength

Non-shrink and high early strength grout are appropriate for precast component connections in order to prevent shrinkage, cracking and debonding at the grout-component interface while expediting the construction process. The compressive strength requirements are stipulated in the AASHTO (2010), ASTMs, and agency specific specifications (Table 2-11).

Compressive strength of the grouts is categorized based on three levels of workability: plastic, flowable, and fluid. The compressive strengths given in Table 2-9 and Table 2-10 correspond to the flowable consistency that is required for most of the grouting operations. According to the manufacturer data sheet, different consistency is achieved by increasing the water content. Increasing water content to reach fluid consistency will result in the lowest compressive strength compared to flowable and plastic. However, the strength reduction can be overcome by utilizing water reducing admixtures to achieve required consistency without increasing water content.

Considering Michigan standard specifications and ASTM C1107 specification requirements, almost all of the available materials qualify for the grouting operation. Whereas, only three cementitious grout materials meet the requirements under AASHTO (2010) stipulations. These are *747 Rapid Setting Grout*, *Sure-Grip® High Performance Grout*, and *Speccrete® Superb Grout* with the 1-day strength for flowable consistency of 7.6 ksi, 5.0 ksi, and 5.0 ksi, respectively. Remaining cementitious grouts gain strength of approximately 5.0 ksi in 3 days, which does not adhere to the AASHTO (2010) stipulations.

Table 2-11. General Requirement for Grouting Materials

Properties	Value	Specification
Compressive strength	5.0 ksi @ 1 days	AASHTO (2010)
	1.0 ksi @ 1 day	ASTM C1107 (performance requirement)
	2.5 ksi @ 3 days	
	3.5 ksi @ 7 days	
	5.0 ksi @ 28 days	
Early age height change ⁺	Maximum @ Final set: + 4.0%	ASTM C1107 and C827
Height change of moist cured hardened grout at 1, 3, 14 and 28 days ⁺⁺	Maximum: +0.3% Minimum: 0.0%	ASTM C1107 and C1090

⁺Early age height change is the measurement of change in height from the time of placement until the specimen is hardened, and it is measured as per ASTM C827

⁺⁺ Height change is either increase or decrease in the vertical dimension of the test specimen, and its measure as per ASTM C1090

2.4.2.2 Freeze/Thaw Resistance

Grout materials with freeze/thaw resistant performance characteristics are required in Michigan. From the list provided in Table 2-9 and Table 2-10, only seven are suitable for freeze/thaw exposure conditions:

- Set 45 or Set 45 HW,
- EUCO-SPEED MP or EUCO-SPEED MP HW,
- Masterflow 928,
- S Grout,
- SonogROUT 10k,
- SikaGrout 212, and
- PRO GROUT 90.

The grouts listed above are suitable for freeze/thaw exposure. Yet, only magnesium phosphate grouts such as Set 45 and EUCO-SPEED MP can develop the strength required by the AASHTO (2010). The AASHTO requirement for the grout is to achieve 5 ksi in 24 hours.

2.4.2.3 Non-Shrink Grout

The non-shrink property of the grout is important to assure the durability performance of the joint. This is because shrinkage may result in grout cracking and grout-component interface debonding. Abating and control of cracking and debonding is necessary in specific climate zones where deicing salts are used or the structures are in chloride rich environments. Cracks

allow rapid penetration of chloride laden surface water resulting in initiating and accelerating the corrosion of reinforcing steel. Non-shrink grouts exhibit expansion after the initial hardening phase by the presence of shrinkage control additives such as *gas generating* (e.g. *Al powder*) and *air release* in the mix (Culmo 2009). Air release occurs when the additive reacts with water to release entrapped air and trigger expansion of the grout (Culmo 2009). This additive is incorporated into *Five Star® Grout* to control shrinkage. For hydraulic-cement grout to be qualified as a non-shrink grout, the maximum early age expansion and hardened state expansion must meet ASTM C1107 requirements on maximum and minimum height change (Table 2-11).

2.4.2.4 *Initial Setting Time*

Magnesium ammonium phosphate grouts achieves a high early strength of up to 5.0 ksi within a very short period of 6 hours after initial setting, and they are consequently suitable for rapid bridge construction. During the strength gain process these grouts generate high temperature. Also, rapid setting leaves very little time for transport, handling, and placing compared to cementitious grouts. This also poses difficulty in grouting larger cavities. As an example, Set 45 and EUCO-SPEED MP have initial setting times of 15 and 12 min., respectively (Table 2-9). Cementitious grout materials allow sufficient working time ranging from 30 min. to 6 hours thus suitable for filling large cavities. However, strength gain is low and requires longer curing duration to attain desired properties. The setting time and rate of strength gain is controlled by exposure conditions. Setting time and strength gain test data needs to be provided in order to validate the suitability of using such material for a specific project.

2.4.2.5 *Grout Pocket Dimensions*

The largest dimension of a grout pocket will define the criticality of shrinkage or heat of hydration properties. Largest fill dimension is sometimes referred to as the fill depth. The fill depth provided in Table 2-9 and Table 2-10, is for neat grout. Grouts can be extended with sand or pea gravel to fill large pockets. Extended grout properties such as consistency, workability, strength, and setting time are not the same as the data presented in manufacturers' data sheets. The rate of strength gain of extended grouts will be lower than values given in the manufacturers' data sheet. As per the information provided in manufacturers' data sheet,

certain grout types such as magnesium phosphate based EUCO-SPEED MP grout is limited to a maximum fill depth of 8 in. This fill depth limitation is valid even for extended grout.

2.4.2.6 Working Temperature Range

The material properties are obtained under specific exposure conditions as stipulated in the standard specifications. For most of the grouts the compressive strength provided in the material data sheet is for a particular working temperature of 73 °F. The recommended temperature range for application depends on grout type (Table 2-9 and Table 2-10). As an example, in Table 2-10 application temperature range of SS Mortar is given as 50 – 90 °F, but Set 45 shows only an upper limit of 85 °F. Magnesium phosphate grout has special types for hot weather grouting such as Set 45 HW and EUCOSPEED MP HW. These grouts can be applied in ambient temperature greater than 85 °F. Another example is the grouting with SikaGrout, which has a working temperature range of 40 °F to 70 °F. It is advised to follow practices similar to hot and cold weather concreting when this grout is used under temperature conditions beyond the specified range. It is recommended to add cold water for temperature greater than 70 °F and warm water for temperature less than 40 °F. These observations further strengthen the need for testing under specific exposure conditions and compiling data available in order to develop a knowledge base.

2.4.2.7 Curing Requirements

The cementitious grouts require wet curing for at least 1 day and further curing or prevention of moisture loss for at least 3 days. Also, some grouts do not require wet curing. As an example, magnesium phosphate grouts, as recommended in the material data sheet, require protection only for moisture loss for at least 3 hours following application. Another example is the UHPC, which also requires protection of moisture loss for about three days. UHPC is often protected with an insulated board cover such as plywood (Perry et al. 2010). This requirement needs to be considered at sites with time constraints for on-site construction.

Based on the information provided in Table 2-9 and Table 2-10 and discussions provided in the above sections, it is recommended that selection of grout for a specific connection needs to be considered at the design stage. In addition to the fresh and hardened grout properties

provided by the manufactures that are listed in Table 2-9 and Table 2-10 additional third party test data is compiled and presented in the section below.

2.4.3 Commercial Grout Properties Documented in the Literature

Grout properties provided in the material data sheet are suitable for preliminary selection of the materials for a specific application. Yet, the data presented by manufacturers is for neat grout. In most cases, use of extended grout is required due to the size of the grout pocket. For this reason, documenting the variability due to exposure, mixing procedures, and grout constituents is required. Experimental data for four different commercially available cementitious and magnesium phosphate based grouts is presented in the Table 2-12. Scholz et al. (2007) conducted testing for neat grout and extended grout to evaluate the strength development. The data shows a significant reduction in compressive strength for extended grouts compared to the neat grouts.

Table 2-12. Experimental Data for Neat and Extended Grouts (Source: Scholz et al. 2007)

		Neat Grout				Extended grout			
		ThoRoc 10-60 Rapid Mortar	SikaQuick 2500	Five Star Highway Patch	Set 45 Hot Weather	ThoRoc 10-60 Rapid Mortar	SikaQuick 2500	Five Star Highway Patch	Set 45 Hot Weather
Aggregate Extension, % by weight		-	-	-	-	50	50	80	60
Compressive strength per ASTM C109 (psi)	1 hr.	2700	1700	910	420	1860	1020	-	-
	2 hrs.	3030	2250	2810	2050	2370	1170	2730	230
	1 day	5210	3540	5080	4930	3150	1900	4490	2650
	7 days	6380	4710	5820	4930	5040	2550	5440	4180
Shrinkage per ASTM C157 (%)	28 days	0.076	0.080	0.029	0.034	0.064	0.089	0.036	0.018
Initial set time (min)		16	24	30	44	19	29	26	35

Compressive strength data documented in literature are compared to the materials data sheets shown in Table 2-13. In the majority of cases, the compressive strength presented in the literature is significantly different than those presented in the material data sheets by the manufacturer. This highlights the importance of conducting mock-up testing in order to evaluate the application procedures and material behavior under anticipated exposure conditions. Also, compiling this test data will help designers' understand the application limitations and property variability of grout. This will, perhaps, allow designers the opportunity to modify connection details to be compatible with the material selected for the particular application.

Table 2-13. Comparison of Manufacturer Data and Laboratory Test Data

	1 day Strength (ksi)				3 days Strength (ksi)			7 days Strength (ksi)				
	a	b	C	d	a	b	c	a	b	c	d	e
Set 45	6.0	-	3.8	-	7.0	-	4.3	-	-	5.5	-	-
Set 45 HW	6.0	6.3	-	4.9	7.0	7.4	-	-	8.3	-	4.9	7.3
EUCO SPEED MP	6.0	5.6	-	-	6.5	6.3	-	7.0	6.9	-	-	-
Set Grout	-	-	2.8	-	3.0	-	5.1	5.0	-	6.3	-	5.9
ThoRoc 10-60	6.5	-	-	5.2	-	-	-	-	-	-	6.4	-

- a. Manufacturer data sheet
- b. Oesterle and El-Remaily 2009
- c. Issa et al. 2003
- d. Scholz et al. 2007
- e. Gulyas et al. 1995

2.4.4 Non-Commercial Grout and Mortar

A review of literature was performed to document potential non-proprietary grouts and special mixes.

2.4.4.1 Ultra High Performance Concrete (UHPC)

Ultra high performance concrete is often suitable for joints in precast construction. As an example, UHPC was successfully used by the Iowa DOT for grouting of dowel pockets at the longitudinal connection between the pi-girders (Figure 2–5). UHPC contains a premix of silica fume, ground quartz, sand, and cement with a mix of brass coated high tensile steel fibers. The fiber diameter is 0.008 in. with length of 0.55 in. A high range water reducing admixture is added to improve the workability of UHPC. The characteristic design strength of 14.5 ksi is achieved at 96 hours (4 days) after casting. During this period of strength development, ambient vibrations adversely affect strength development by perhaps disturbing fiber orientation. The exposed surface of the UHPC connection often requires grinding because there is a tendency of steel fibers protruding out of the surface (Perry et al. 2010).

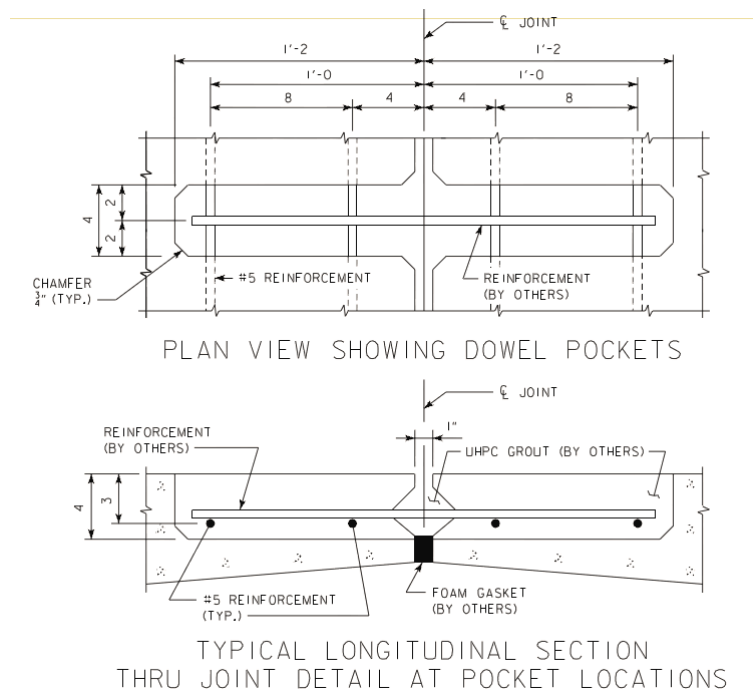

Figure 2–5. UHPC grouted dowel pockets in UHPC girders (Source: Bierwagen 2009)

An example of typical field-cast UHPC materials mix design and its properties are given in Table 2-14 and Table 2-15.

Table 2-14. UHPC Mix Design (Source: Graybeal 2010a)

Material	Quantity (lb/yd³)
Portland cement	1200
Fine sand	1720
Silica fume	390
Ground quartz	355
Superplasticizer	51
Steel fibers	263
Water	218

Table 2-15. UHPC Material Properties (Source: Graybeal 2010a)

Material characteristic	Average results
Density	155 lb/yd ³
Compressive strength (ASTM C39; 28-day strength)	18.3 ksi
Modulus of elasticity (ASTM C469); 28-day modulus)	6200 ksi
Long-term shrinkage (ASTM C157; initial reading after set)	555 microstrain
Total shrinkage (Embedded vibrating wire gage)	790 microstrain
Freeze-thaw resistance (ASTM C666A; 600 cycles)	RDM = 112%

2.4.4.2 Cement Mortar Specified in Michigan

Type R-2 Grout class is often specified for side-by-side box-beams shear keys (Aktan et al. 2009). Various R-2 mixes were evaluated in an earlier study (Table 2-16). Also, a set of samples was collected from an MDOT bridge project that is labeled as BB in Table 2-16. The mix design of the grout obtained from the MDOT bridge project is also given in Table 2-17. Remaining samples were prepared based on the proportions given in the MDOT Standard Specification for Constructions. As seen in Table 2-18, R-2 grout strength development is slow and not suitable for most accelerated construction projects.

Table 2-16. Type R-2 Grout Description (Source: Aktan et al. 2009)

Mix ID	Description
BB	Type 1 Portland cement. Provided by Consumer's Concrete and used in Oakland over I-94 bridge
BBA	Type 1 Portland cement – Laboratory mix
BBM	Type M masonry cement – Laboratory mix
BBN	Type 1 Portland cement and Type N masonry cement – Laboratory mix
BBS	Type 1 Portland cement and Type S hydrated lime – Laboratory mix

Table 2-17. Type R-2 Grout Mix Design

Mix ID	Materials	Quantity
BB	Portland cement ASTM C150 (Type I), lbs	930
	Fine aggregate MDOT (#4 - #100), lbs	1956
	Water, lbs (gal)	416 (49.8 gal.)
	Air entraining ASTM C260, oz	46.0
BBA	Portland cement (Type I), lbs	930
	Fine aggregate (#4 - #100), lbs	1996
	Water, lbs	415
BBM	Masonry cement (Type M), lbs	930
	Fine aggregate (#4 - #100), lbs	2137
	Water, lbs	415
BBN	Portland cement (Type I), lbs	468
	Masonry cement (Type N), lbs	349
	Fine aggregate (#4 - #100), lbs	1991
	Water, lbs	415
BBS	Portland cement (Type I), lbs	828
	Hydrated lime, lbs	75
	Fine aggregate (#4 - #100), lbs	2016
	Water, lbs	415

Table 2-18. Compressive Strength of Type-R-2 Grout (Source: Aktan et al. 2009)

Age (Days)	Strength (psi)				
	BB	BBA	BBM	BBN	BBS
3	3,730	2,693	2,125	1,916	2,470
7	3,651	3,668	2,358	2,693	2,899
14	4,385	4,256	2,646	3,377	3,403
28	4,859	4,309	2,677	3,680	3,626

2.4.4.3 High Performance Concrete

Five different high performance concrete mixes were developed for the NCHRP 10-71 project (Table 2-19). These mixes are recommended for closure pours at longitudinal connections between the flanges of deck bulb tee sections (DBTs) and between precast panels. The mixes require a 7 day wet curing. Only three out of five mixes were tested, and the 7-day compressive strengths were recorded as 6.5 ksi, 4.1 ksi, and 5.1 ksi. High performance concrete may not be suitable for accelerated bridge construction projects due to slower strength development compared to commercial non-shrink grout materials.

Table 2-19. Mix Design for High Performance Concrete (Source: French et al. 2011)

	Mix-1	Mix-2	Mix-3	Mix-4		Mix-5	
w/c Ratio	0.31	0.35	0.31	0.32		0.35	
Cement type	I	I	II	I/II		I/II	
Cement Quantity, lb/yd ³	750	474	490	563		431	
Fly Ash Type C Quantity, lb/yd ³	75	221	210	75		58	
Slag Quantity, lb/yd ³				113		86	
Fine Aggregate, lb/yd ³	1400	1303	1365	1161		1308	
Coarse Aggregate Maximum Size, in	0.5	1	1.25	1.5	0.5	1.5	0.5
Coarse Aggregate Quantity, lb/yd ³	1400	1811	1900	1530	270	1520	380
Air Entrainment, fl oz/yd ³	5	-	3.1	3		2.3	
Water reducer, fl oz/yd ³	30	-	-	-		-	
Retarder, fl oz/yd ³	-	22	28	-		-	
High-Range Water Reducer, fl oz/yd ³	135	122	156	60		46	
Shrinkage Reducing Admixture, fl oz/yd ³	-	-	-	32		24.7	
Compressive strength (psi) per ASTM C39 Modified	7-day	6494	-	-	4112		5058
	28-day	8895	-	-	5269		7309

2.4.5 Grouting Operation

In addition to exposure conditions and strength requirements, connection details should also be considered in specifying the grouting. The connection geometry is critical in specifying the grout. This is because with most grouts fill depth being limited, and grouts require extending for larger volume. Reinforcement details are also important for proper workability and sufficient consolidation. For a particular application, conducting mock-up tests on potential grouts would be useful to evaluate the mixing and placement procedures, as well as strength development under anticipated exposure conditions. Mock-up tests can also be useful in training the grouting crew.

All grouting operations require wetting the precast element surfaces to attain saturated-surface-dry condition before placing the grout or special concrete. Generally, wetting of the component surfaces should start at least 4 hours before the grout placement. Most grout material data sheets; however, recommend wetting process to start 24 hours before placement.

Surface preparation is important and a critical factor for the bonding between the grout and the precast elements. The surface should be cleaned from any foreign materials, and the joints should be roughened or mechanically abraded to allow forming a mechanical bond between the grout and the precast elements. Reinforcement at the joints should be thoroughly cleaned and free from rust. Cementitious grout with non-shrink properties is often recommended in precast construction due to assumed material compatibility of the grout with precast elements. The material data sheet for magnesium phosphate grouts indicates the need for special surface preparation to enhance bonding at the grout - component interface. Once the surface is prepared, the magnesium phosphate grout will provide desired bonding properties as per the manufacturer data sheet.

Another factor that promotes grout cracking and failure at the grout - component interface bond is ambient vibrations propagating from traffic or other construction operations. Some grouts, mostly those requiring longer setting time are sensitive to the structural vibration. One such example is ultra-high performance concrete (UHPC) (Perry et al. 2010). Vibration impact should be considered for staged construction.

Grout placement methods include dry packing, gravity flow (pouring), and pumping. Dry packing is commonly used for shear keys. Grout mixed at flowable and fluid consistency can be pumped into tight spaces and sharp corners of the joint cavities (Figure 2–6, Figure 2–7). The pumping process requires a leak proof formwork that can withstand the pressure. Joints are normally sealed with a foam backer rod, which is flexible but not sufficient for pressure grouting operation.



Figure 2-6. Grouting adjacent box-beam shear keys using type R-2 grout (Oakland Drive over I-94, MI)



Figure 2-7. Pumping W.R. Meadows Sealight CG-86 non-shrink grout (Source: Oliva et al. 2007)



Figure 2-8. Grouting of full-depth deck panel connections (Source: Courtesy of MDOT)

Connections with narrow access for grouting should have a vent pipe to prevent entrapped air voids. Care is required while grouting connection cavities with sharp edges and corners (Figure 2–9).

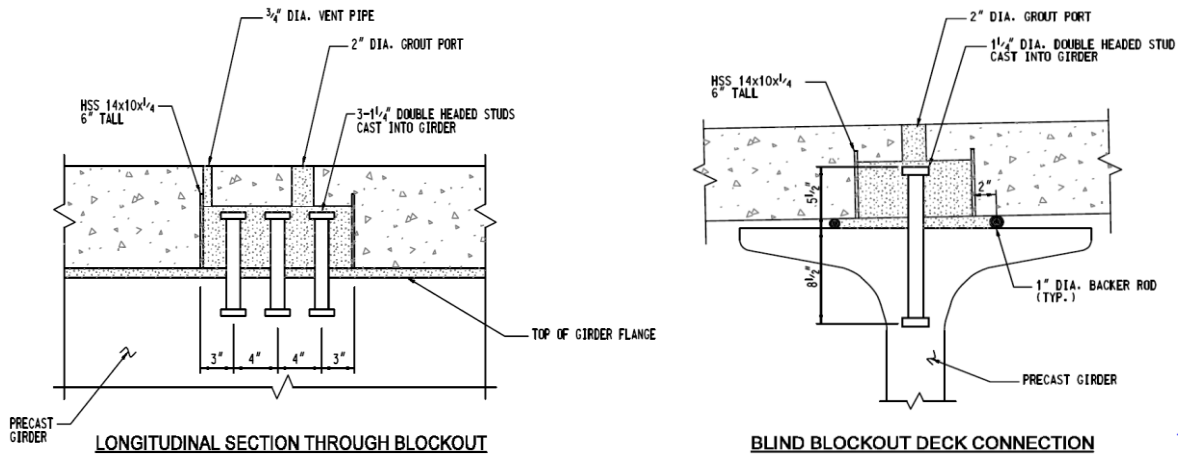

Figure 2–9. Joint details of panel-to-prestressed concrete I-girder connection with confined space, sharp edges, and corners (Source: Culmo 2009)

As indicated earlier, properties of neat grout may be different than those stated in the data sheets. Hence, (1) compiling available data of extended and neat grout properties, (2) evaluating grout properties through appropriate testing under various exposure conditions, and (3) evaluating grout application procedures using mock-up specimens will provide evidence to assure the compatibility of the material for a specific connection, application procedure, exposure conditions, curing requirements, and project schedule.

2.4.6 Summary and Conclusions

A grout can be specified based on properties such as compressive strength, freeze/thaw resistant, non-shrink properties, initial setting time or working time, grout pocket dimensions, working temperature range, application procedures and limitations, and curing requirements. Following identifying the grout based on the information in the material data sheet, it should be tested and evaluated for the particular field application before implementation.

2.5 ACCELERATED BRIDGE CONSTRUCTION AND DECONSTRUCTION METHODS AND EQUIPMENTS

2.5.1 Accelerated Bridge Construction Methods and Equipment

Literature documents numerous innovative and creative techniques used by various agencies to accelerate the bridge construction process. These techniques have been developed through the process of exchanging ideas between design, fabrication, and construction teams. The “International technology scanning” program was a joint effort by the Federal Highway Administration (FHWA) and the American Association of State Highway and Transportation Officials (AASHTO) in 2002 to review and identify global innovations for leveraging to the U.S. transportation infrastructure industry. Several innovations were identified and implemented by contractors to accelerate the construction process. Ralls et al. (2005) reports the popular techniques used for accelerated construction in various parts of the world as these:

- Vertical lifting of prefabricated components with large cranes to assemble the bridge system,
- Longitudinal incremental launching of bridges above existing highways,
- Moving a complete built system with a series of vehicles known as Self-Propelled Modular Transporters (SPMTs),
- Moving a complete built system by horizontal skidding or sliding into place,
- Building bridges alongside an existing roadway and rotating them into place, and
- Vertical lifting of the complete built system and placing into required alignment.

Several construction projects (case studies) that are listed below were reviewed to understand and document these technologies.

- Oakland Eastbound I-580 Connector in San Francisco Bay Area, California
- Russian River Bridge in Geyserville, California
- San Francisco Yerba Buena Island Viaduct in Oakland, California
- I-70 over Eagle Canyon, Utah
- I-215; 4500 South Bridge in Salt Lake City, Utah
- Five bridges on OR-38 between Drain and Elkton, Oregon
- U.S. 15/29 over Broad run in Prince William County, Virginia

- State highway 86 over Mitchell Gulch in Douglas, Colorado
- I-80 State street to 1300 east in Salt Lake City, Utah
- Mill Street Bridge, New Hampshire
- Tucker Bridge in Utah
- Lewis and Clark Bridge between Washington and Oregon
- Sam White Bridge in American Fork, Utah
- Parkview Bridge, in Kalamazoo, Michigan
- 120th Street Bridge in Boone County, Iowa
- Route 99/120 separation bridge in Manteca, California
- Skyline Drive Bridge over West Dodge Road in Nebraska
- I-215 East Bridge over 3760 South in Utah
- MD Route 24 Bridge over Deer Creek in Maryland
- I-40 Bridge in southeastern California
- Replacement of a Bridge in a high seismic zone of western Washington State
- Fast 14 Project in Medford, Massachusetts
- M-25 over the White River in Huron County, Michigan

2.5.2 Accelerated Bridge Deconstruction Methods and Equipment

Numerous types of demolition techniques are available. They are demolition by machine, by chemical agents, and by the use of hand-held tools, etc. (BSI 2000). Nevertheless, some of these techniques may pose difficulties in practice due to complicated site conditions and various constraints on noise, dust, and vibration. According to Abudayyeh et al. (1998), the parameters that need to be considered in defining the bridge demolition techniques include the following:

- Location and accessibility,
- Shape and size of the structure,
- Time constraints,
- Transportation consideration,
- Financial constraint,
- Recycling consideration,

- Environmental consideration,
- Health and safety,
- Client specification,
- Stability of structure,
- Presence of hazardous material, and
- Degree of confinement.

New techniques are being proposed for bridge demolition. The following sections will highlight some of the new developments and will list the techniques that are currently in practice for bridge demolition.

2.5.2.1 Accelerated Bridge Demolition Techniques

New demolition methods and equipment are now available for a fast and safe demolition of bridges. One example is the Self Propelled Modular Transportation (SPMT) systems that are used for transporting massive objects such as bridges and buildings (Ardani et al. 2009). The Hyspec (hydraulic, self-powered, and electronically controlled) is one SPMT system that has been tested for removal and transport of the Warren Farm bridge structure to an adjacent set-down area without creating any debris (Anumba et al. 2003). The Warren Farm Bridge carrying over M1, located in Nottinghamshire, UK, was successfully removed using a Hyspec SPMT system (Anumba et al. 2003). Before the closure of the bridge, the exact location of lifting and maneuver positions were defined on M1. The computer on the Hyspec system was programmed with the accurate coordinates of adjacent set-down area before the closure of M1. A non-abrasive hydrodemolition technique was used for making the concrete cuts close to the abutment. The reduction of shear capacity because of removal of the concrete at the end of the bridge deck was accounted for the jacking process. A diamond saw was used to cut the reinforcement. Once the Hyspec system was positioned under the bridge, the jacking frame was positioned at the bottom of the bridge for lifting (Figure 2–10). The structure that was detached at the abutments and column foundations was transported to the set-down area adjacent to the bridge and was then jacked down on to temporary supports. Hydraulic hammers were then used to remove the reinforced concrete bridge deck and the bridge abutment.



Figure 2–10. Transportation of the Warren Farm Bridge (Source: Anumba et al. 2003)

Another example is the accelerated demolition of the 4500 South Bridge in Utah using a remotely-operated SPMT system (Ardani et al. 2009). The SPMT system was equipped with two sets of 16 axles and a hydraulic system that can lift and lower the structures within a vertical range of 24 inches. Prior to removal of the structure, the asphalt overlay, bridge railings, concrete median, and approach slabs of the structure were sawed off. The SPMT was used to lift and move the two-span superstructure of the bridge to a demolition area (Figure 2–11). The SMTP made two trips (one per span) and took 4 hours to complete the removal of the superstructure. After removing the existing superstructure to the demolition area, the existing columns and bent caps were demolished using hydraulic hammers.



Figure 2–11. Removal of the bridge using SPMT system (Source: Ardani et al. 2009)

The demolition of Silas N. Pearman bridge over Cooper River in Charleston, South Carolina was also accomplished in an accelerated manner using the hydraulic jacking method (Singh et

al. 2008). The hydraulic jack system was attached by cables to the main span from the upper girder through the lower girder (Figure 2–12a and Figure 2–12b). The upper and lower girders of the main span were disconnected from the east and west cantilever sections. The hydraulic jacks were computer controlled and displayed the position of the jacks. After cutting the spans, the truss section was lowered on barges on the river positioned under the main span. Following lowering of the main span, the cables were detached from the truss section. The main span was then shipped to a yard for demolishing (Starmer and Witte 2006). The removal of the span was completed in few hours.

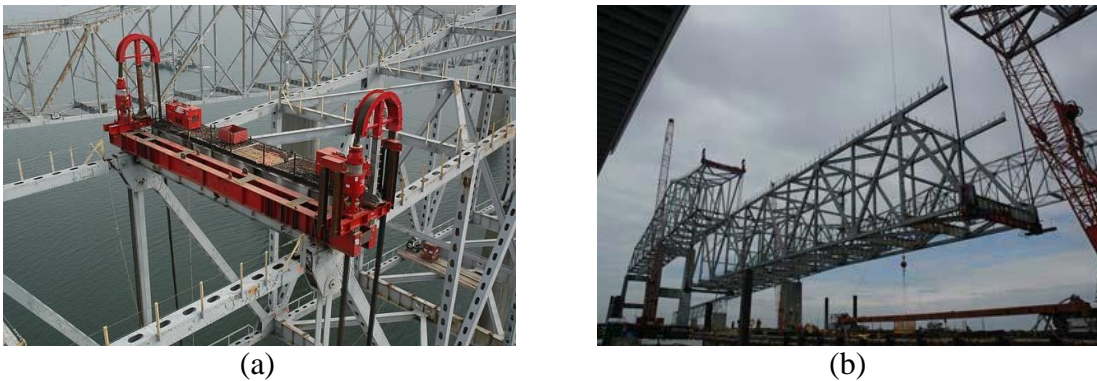

Figure 2–12. Hydraulic Jack attached on the bridge (Source: Singh et al. 2008; Starmer and Witte 2006)

Crossings 3 and 4 on Oregon Highway 38 were removed using the accelerated hydraulic sliding system (HSS) method (Ardani et al. 2010a). The HSS includes hydraulic jacks with sliding rails and hydraulic pumps for lifting the superstructure (Figure 2–13). Temporary supports were constructed next to the bridge. Sideways were constructed to translate the superstructure of the bridge. The asphalt overlay and approach slabs were cut and crushed using hydraulic hammers and pulverizers. Hydraulic pumps generate power to move the hydraulic jacks that slide the superstructure on the rails. After removal of the superstructure, the temporary support systems and superstructure were dismantled and removed off-site. This HSS was also used for the Capilano River bridge replacement in West Vancouver, Canada and Milton-Madison bridge replacement over the Ohio River in Indiana.



Figure 2–13. Hydraulic Sliding System (Source: Ardani et al. 2010a)

2.5.2.2 Traditional Demolition Methods

In this section, traditional bridge demolition methods and equipment are discussed.

- *Ball and Crane*: The ball and crane technique uses a steel ball suspended from the end of a crane (Transportation Research Board 1991) to demolish a structural component. This technique is used to break the concrete structure into pieces by either dropping the ball vertically on to the structure, or by swinging the ball on to the side of the structure.
- *Hydraulic Attachments*: Hydraulic attachments can be mounted on cranes and excavators to cut steel and crush the concrete structure. Hydraulic attachments have to be identified based on the materials that are being demolished. The most common hydraulic attachments are these:
 - *Impact Hammer*: An impact hammer is used to demolish masonry and concrete structures by applying force to a point (Figure 2–14a). It may be pneumatically or hydraulically operated (BSI 2000).
 - *Hydraulic Hammer*: Hydraulic hammers are mounted on excavators for demolition of bridge decks, piers, slabs, and pavements (Abudayyeh et al. 1998).
 - *Hydraulic Shears and Pulverizer*: Metal and reinforced concrete sections can be cut using shear jaws. A shear attachment can be mounted to an excavator for cutting (Figure 2–14b).

Demolition of the Parkview Avenue bridge in Kalamazoo, Michigan was accomplished using hydraulic hammers, excavators, and cranes. Two hydraulic hammers were used to demolish the old reinforced concrete deck (Figure 2–14c). The debris was removed to the side and crushed using excavators (Figure 2–14d). After demolition of the deck, the girders were removed using a crane by attaching cables to the ends of the girders for lifting. The piers were demolished using hydraulic hammers. The demolition of the bridge was completed in 8 days.



(a) Hydraulic Impact Hammer
(Source: IMECO 2011)



(b) Hydraulic Shear



(c) Hydraulic hammer



(d) Excavator

Figure 2–14. Equipment used in traditional bridge demolition process

- *Remotely Controlled Machines and Robotic Devices:* Remotely controlled machines and robotic devices are used when there are potential hazardous conditions. These machines can be controlled remotely at a safe distance from the demolition site (BSI

2000). They can be equipped with buckets, hydraulic hammers, a pulverizer, and drilling equipment (Figure 2–15).



Figure 2–15. Remote demolition machine Brokk 330 (Source: <http://www.brokkinc.com/brokk-330.html>)

- *Drilling and Sawing:* Drilling and sawing techniques are used to create holes or cut a portion of a structure. Diamond core drill and diamond floor sawing can also be used in demolition work. The diamond core drilling method is a vibration free method that creates holes in concrete. It can be powered by electricity, hydraulics or compressed air. The diamond floor sawing method is used for cutting trenches, expand joints, or remove slabs (BSI 2000).
- *Explosives:* Explosion methods have been used for complete demolition of concrete structures. They have many advantages such as cost effectiveness, time saving, and eliminating the need to use heavy machinery. They are also useful in cases where site access is limited (BSI 2000). For large structures, an experienced explosive engineer should manage the planning and execution process. Explosives may include gels, granules, powders, cord, liquids, plastics, and dynamite. The specifications of all explosives must be analyzed before using for safety considerations.
- *Barge Mounted Crane:* The demolition of Grace Memorial and Silas N. Pearman bridges in Charleston, South Carolina were accomplished using explosive techniques (Singh et al. 2008). The deck sections of the bridge were cut by saw and excavators with hoe rams. After removing the deck sections and the steel girders using a barge-mounted crane, the superstructure truss sections were demolished using explosive techniques.

- *Bursting*: This technique is used for the demolition of concrete, masonry, and rock. Gas expansion bursters and expanding demolition agents are two technologies in use for demolishing structures (BSI 2000).
 - Expanding demolition agents: This technique is used for reinforced concrete cutting. The chemical powder is mixed with water before pouring it into drilled holes (Archer Company 2011). The chemical composition of the agent includes calcium hydroxide that expands when the mixture hydrated. The 18,000psi pressure generated by the chemical mixture can break reinforced concrete without noise, vibration, or dust.
 - Gas expansion bursters: A gas burster is inserted in drilled holes. After being energized, high pressure fractures the component (BSI 2000).
- *Hydrodemolition*: This technique is used to cut concrete from steel reinforcing bars. Water mixture includes additives and abrasives to increase the pressure of water in the demolition process (BSI 2000). Hydrodemolition equipment consists of water-pumps, high-pressure hoses, high-pressure water nozzles, and a mobile housing unit for the water nozzles (Abudayyeh et al. 1998).

2.5.3 Safety Issues in Bridge Demolition

The process of bridge demolition requires careful planning, execution, and inspection to establish and maintain a safe work environment (Abudayyeh 1997). Bridges that cross environmentally sensitive waterways may need to be demolished using methods that do not create debris (Abudayyeh et al. 1998). Before selecting the demolition technique, the contractor should consider workers' protection, the safety of the public, adjacent structures, existing utilities, and the environment.

2.5.3.1 Protecting Workers and Safety of the Public

To ensure adequate protection to the workers and the public, the contractor and the owner should follow these steps:

- Develop proper demolition plans showing the demolition sequence, staging, equipment location, restraints and falsework for structural stability, and traffic control.

- Develop a comprehensive "Code of Safe Practice" that includes a plan for the use of personal protective equipment (hard hats, safety glasses, construction boots, tie-off, protective clothing, seat belts, and canopies).
- Develop a maintenance plan for keeping all pieces of equipment on the job in good working condition for the duration of the project.
- Develop a dust control plan (e.g., use of water sprays).
- Develop a plan to prevent debris from injuring the public and the workers (i.e., use debris nets).
- Develop a plan to control noise (i.e., observe work-hour schedules and monitor vibration and noise levels).

2.5.3.2 *Protecting Utilities*

Two types of utilities may exist in the vicinity of a demolition project: underground and overhead. Underground utilities may include gas mains, water pipes, and sewer lines. Overhead utilities may include power and telephone lines. To protect underground utilities, a number of measures can be taken:

- Debris piles may be built on top of such lines to provide a cushion against impact from falling objects.
- Steel plates may also be used as covers to protect against impact.
- High-pressure water lines should be shut down within the demolition zone.
- No large size debris should be allowed to fall freely.

To protect overhead utilities, the contractor and the owner should work closely with the responsible agency to arrange for a temporary shutdown and removal of utility lines in the immediate vicinity of the demolition site. Accurate schedules should always be sent to utility agencies to minimize service disruption and inconvenience to the public.

2.5.3.3 *Protecting Adjacent Structures*

One of the major challenges during a bridge demolition project is the protection of adjacent structures. Some of the measures that can be taken include the following:

- All hinges on the spans of a bridge should be restrained using steel cables or rods to prevent a premature collapse by slipping off the hinge seat.
- All possible loads on a bridge should be analyzed to establish a safe loading range before demolition starts to ensure that spans do not become overloaded with debris and/or heavy equipment.
- All columns should be restrained to prevent a premature collapse in the direction of adjacent structures.
- A monitoring program may also be established to prevent vibrations from exceeding the maximum limits for adjacent structures.

2.6 CONSTRUCTABILITY AND ELEMENTS OF A CONSTRUCTABILITY PROGRAM

2.6.1 Constructability

Knowledge and experience from previous construction projects are extremely valuable to improve constructability of an upcoming project. Therefore, a constructability review is the key to improving the project buildability, bidability, and reducing errors; thus, reducing contract change orders. Constructability may also reduce the life-cycle cost of a project. Constructability is formally defined as (AASHTO 2000):

“a process that utilizes construction personnel with extensive construction knowledge early in the design stages of projects to ensure that the projects are buildable, while also being cost-effective, biddable, and maintainable.”

The above definition is complemented by the definition given in Gambatese et al. (2007) *“the integration of construction knowledge and experience in the planning, design, procurement, construction, operation, maintenance, and decommissioning phases of projects consistent with overall objectives.”*

A survey was conducted on constructability in the states of Washington, Oregon, and Nevada during 1998 and 2003. Ninety-nine of the 106 designers (93%) and 39 of the 52 constructors (75%) who completed the surveys indicated that constructability was formally considered. Additionally, a formal review process was reported by 71% of the respondents as the most

commonly used practice in addressing constructability issues on construction projects. Other practices that were reported included plan reviews, project meetings, and value engineering reviews. In response to when the constructability reviews were conducted during a project life cycle, the constructors responded that these activities took place during the preliminary engineering phase, design, and construction. With regard to the members of the project team who need to address constructability, the responses included the involvement of constructors and designers as important constituents in addressing constructability. The survey also explored success measures in addressing constructability. Responders listed final construction cost, constructor feedbacks, and number of change orders as the most important metrics they use in evaluating the performance of constructability (Dunston et al. 2005).

Another survey performed within a project revealed that only a small percent of the state transportation agencies implemented a constructability review process (CRP) in their projects. The reasons were given as CRP requires significant time, cost, and effort (Dunston et al. 2005). The project concluded that flexible CRP implementation guidelines and effective involvement of contractors are crucial for successful implementation. Despite the apparent additional costs associated with the implementation of a constructability program, employing constructability reviews in projects includes many advantages such as the reduction in overall project and construction costs, the decrease in the number of construction change orders, improvements in project quality and safety, and shorter construction schedules. The maximum benefit from a constructability review is achieved through the early involvement of individuals with construction knowledge and experience in the design of a project. There are also challenges to including constructability reviews that need to be overcome. These topics will be detailed in the following subsections.

2.6.2 Constructability Benefits

Tangible and measurable benefits must be recognizable for the successful implementation of a constructability program. Promoting a unified vision for the agency must be set as a goal, and widely communicating the benefits of constructability will substantially increase the buy in of all parties involved. Below is a list of benefits of implementing constructability programs (Russell et al. 1994, Griffith and Sidwell 1997):

- Improved problem avoidance,

- Improved safety,
- Improved site layout,
- Reduced amount of re-work,
- Reduced change orders,
- Better communication,
- Increased commitment from team members.
- Better conceptual planning,
- Effective procurement,
- Improved design,
- Appropriate construction methods,
- Accomplished site management,
- Effective team work,
- Greater job satisfaction,
- Increased project performance,
- Enhanced recognition,
- Reduced engineering cost,
- Reduced construction cost,
- Reduced delays, and
- Short and accurate schedule.

2.6.3 Constructability Implementation Challenges

In order to implement a constructability program, mutual trust, credibility, and respect between designers, project planners, and contractors is essential. However, there are some challenges with the implementation of a constructability program. Below is a summary of such challenges (Arditi et al. 2002; Uhlik and Lores 1998; Jargeas and Van der Put 2001; O'Connor and Miller 1994):

- Traditional contracting practices pose difficulties in implementing constructability programs. This is true in competitive bidding environments, where opportunities for collaboration between owners, designers, and constructors are lacking. In fact, the

- adversarial nature of such environments prohibits any collaboration possibilities due to the limitations in open communication between the parties involved with a project.
- Lack of initiative on the part of owners to commit funds and/or the resources (i.e., personnel) needed to develop and properly manage a constructability program.
 - Lack of construction experience and fundamental knowledge by the designers who are reluctant to include contractors in constructability review.
 - Rigid specifications pose difficulties as they limit design flexibility, reducing their ability to propose alternatives that will improve constructability.
 - Agencies reluctance to invest time or money in training the project personnel on constructability.
 - Designers may resist the implementation of constructability programs, particularly with concerns on discovering inadequate designs, drawings lacking detail, or incomplete specifications.

2.6.4 Essential Elements of a Constructability Program

The constructability review process identifies potential conflicts that may lead to change orders, disputes, cost overruns, and delays during the construction phase of a project. To achieve the goal of any constructability program, a few key elements must be present, including the following (CII 1993):

- **Commitment to Constructability:** To demonstrate a strong commitment to constructability and to become proficient in understanding its concepts, agency leadership needs to develop a constructability implementation policy. The policy needs to include clearly defined organizational goals and training requirements of the project personnel through seminars and training courses. The distinction between constructability and value engineering must be understood.
- **Establish a Constructability Team:** The second element for constructability implementation is establishing a constructability program team. A typical team consists of the construction project manager, the agency's project manager, and project design engineers. These members are responsible for the approval of constructability suggestions. They also arrange for the participation of other potential constructability team members such as subcontractors, construction superintendents, permit and utility

representatives, regulatory representatives, railroad representatives, fabricators, material suppliers, and other specialty contractors in order to provide input into areas requiring specific construction expertise. The team should have deep technical expertise and strong communication skills.

- **Define Constructability Objectives and Measures:** Constructability objectives can be defined after the team is identified. Typically, the main constructability objectives include improving quality, enhancing safety, and reducing project schedule and life-cycle costs. The team should develop a list of project objectives. Appropriate measures for assessment of each objective should be identified. These measures may be capital dollars, construction dollars, direct field labor hours, labor productivity, design rework work-hours, shut-down duration, jobsite accessibility, etc.
- **Select Project Contracting Strategy:** The contracting strategy has an important influence on constructability and needs to be selected to facilitate the collaboration of all parties involved with a project. An agency should consider construction expertise that can increase the success of the constructability effort. The agency may review existing resources and perform a self-assessment to determine what constructability expertise is needed.
- **Develop Constructability Procedures:** Constructability activities need to be developed for every phase of the project and are best integrated with project schedule. Below is a list of selected constructability concepts to consider when implementing the constructability program:
 - The constructability effort begins with the conceptual planning phase and continues through design, procurement, construction, and turnover phases.
 - The constructability team needs to develop a schedule for the various constructability studies and design inputs.
 - Constructability procedures and checklists can be developed utilizing lessons learned from past projects.
 - Experts, when needed, can be included in the meetings.
 - Professional estimating and scheduling support may be needed for complex analyses.
 - Design details need to be verified prior to the release of the design package.

- At project acceptance, the constructability team needs to assess the project performance and evaluates the lessons learned for use by constructability teams of future projects.

Document Lessons Learned: Gaining knowledge from previous experiences is the key for continuous improvement of the constructability process. Lessons learned need to be well documented to prevent oversights in future projects, and they need to be documented during the design and construction phases and included in a database for use in future projects.

2.7 STATE-OF-THE-ART DECISION-MAKING MODELS

Traditionally, bridge construction, rehabilitation or a repair decision is made by a team of experts utilizing scoping reports of planned sites. Decisions are mostly influenced by bridge condition, available funding, and mobility. Understanding the need for selecting the construction alternative between cast-in-place and accelerated construction, Ralls (2005) developed the first decision-making model. Later, alternative models were developed to complement the simplifications of the first model.

Reviews of decision-making models used in other disciplines as well as the pertinent mathematical models are presented. Also, the evolution of accelerated bridge construction (ABC) decision-making models as well as their limitations is discussed in the following sections.

2.7.1 Decision-Making for Outsourcing and Privatization of Vehicle and Equipment Fleet Maintenance

This decision-making model was developed by Wiegmann and Sundararajan (2011) and described in the *National Cooperative Highway Research Program (NCHRP) Report 692*. The model helps the fleet management agencies with outsourcing or insourcing decisions on fleet maintenance and business environment. Three outsourcing options are available in the decision making model. They are equipment class, maintenance service type, and organizational unit. The model defines process in phases, activities, decision points, and relevant evaluation criteria in a logical sequence for arriving at various outsourcing decisions. In Figure 2–16, high-level processes (1 to 5) are arranged in a sequence. Each *process* is described using secondary-level flowcharts that consist of activities and decision points.

Following the flowchart will drive the decision-maker towards the decision. The secondary-level flow chart for *process-1* is shown in Figure 2–17. Each section of this flowchart provides the relevant evaluation criteria to be documented during the decision-making process.

The limitations of this model with potential to use in ABC decision-making are the following:

- A common strategy of answering *Yes/No* is used without any relative significance of critical criteria.
- Contemplating the flowchart without a mathematical model is considered obsolete in engineering and computing practice.

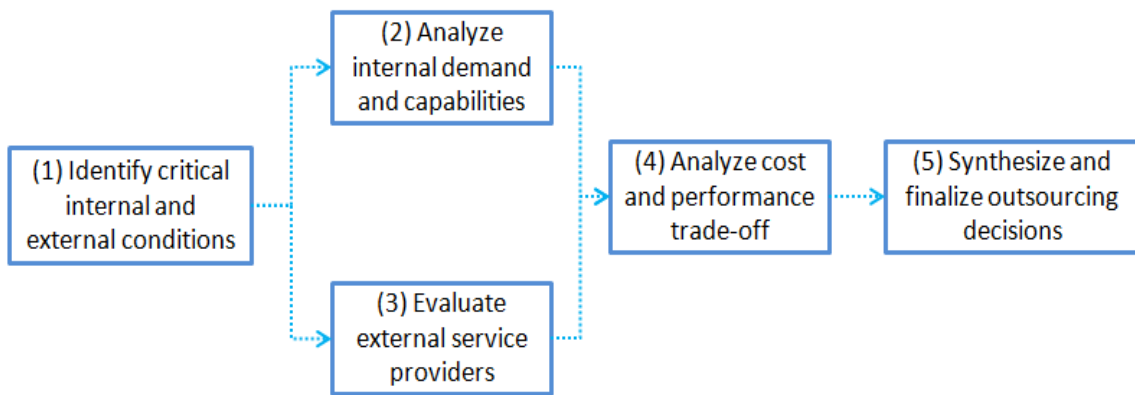

Figure 2–16. High-level outsourcing decision process (Source: Wiegmann and Sundararajan 2011)

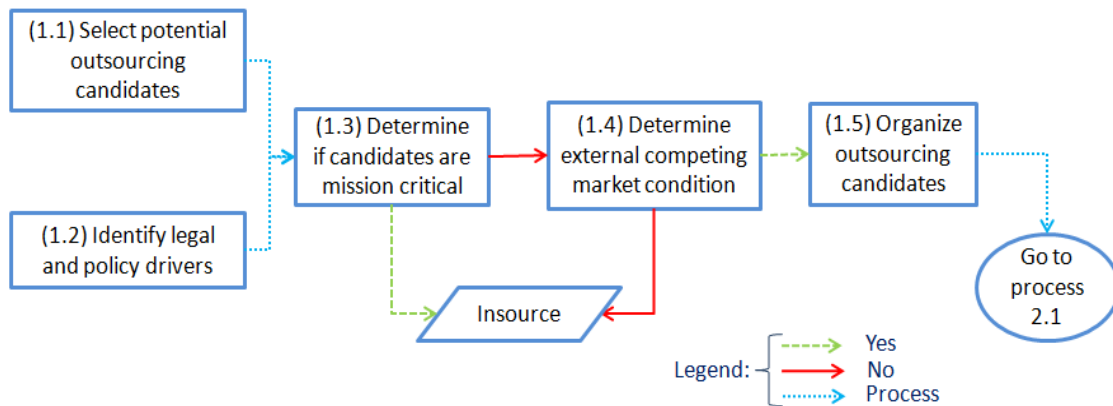

Figure 2–17. The secondary-level flow chart for process 1 to identify critical internal and external conditions (Source: Wiegmann and Sundararajan 2011)

2.7.2 Matrix–Based Decision Support Model for Pavement Rehabilitation Activities on High-Volume Roads

Carson et al. (2008) developed a matrix-based decision support model to assist state highway administrators in determining effective *strategies* on pavement rehabilitation activities. The activities are: i) construction, ii) traffic management, and iii) public information (outreach).

The model consists of three sets of decision-support matrices, which are: (1) a preliminary strategy selection matrix, (2) secondary strategy selection matrices that are focused on construction, traffic management, and public information (outreach), and (3) an interdependency matrix that evaluates the relative level of interdependence between the strategies. Highway administrators evaluated the decision-support matrices in three steps to identify the *effective strategies*. Several strategies were considered for developing the decision-support matrices. The strategies were grouped as such:

- Contract administration,
- Planning-scheduling,
- Project management,
- Constructability,
- Construction practices,
- Traffic control, and
- Public relation (or outreach).

The construction traffic management and public information priorities are represented in the preliminary strategy selection matrix by the columns (Figure 2–18). The strategies that can be used to address those priorities are represented by the rows (Figure 2–18). In order to explain the process only *contract administration*, *planning-scheduling*, *project management*, and *constructability* strategy groups are presented in the Figure 2–18. Three data sources, literature, case studies, and opinions from experts, were used to identify the best strategies to address construction and traffic management and public information priorities. Support from three data sources (i.e., literature, case studies, and opinions from experts) is represented as three equal segments of a circle. When all three data sources support a strategy, the circle is fully shaded and placed in the respective location of the matrix. As an example, all three data sources support the strategy to conduct a *formal constructability review* under the *constructability* strategy group and to address the priority of *Minimized Traffic Impacts* listed under traffic management and public information (Figure 2–18, row CO1 and column 25). Similarly, when only one data source supports a strategy to address a particular priority, only one-third of a circle is shaded and placed at the respective location of the matrix. As an example, only one data source supports the strategy of having *on-site agency decision makers*

under the *project management* strategy group to address the early *project completion* priority listed under construction (Figure 2–18, row PM3 and column 4). A blank cell in the matrix is used to represent that there is no relation among the corresponding *strategy* and *motivation or concern*.

During the initial step of the decision-making process, based on the support from a majority of the data sources, the highway administrators may contemplate the preliminary strategy selection matrix to select the strategies relevant to the specific pavement rehabilitation project.

Strategy	Motivations or Concerns																								
	Construction													Traffic Management and Public Information											
	Owner-contractor cooperation	Common owner-contractor objectives	Worker safety	Early project completion	Set construction window	Short construction segments	Resource intensive, complex construction	High concrete production rates	High concrete quality	Exclusion of risky contractors	Reduced project costs	Alternative selection using design life	Minimized concrete haul times	High public visibility	High traffic volume	Predominant weekday commuters	Predominant weekend traffic	Directional traffic	Impacted local residents	Impacted local businesses	Alternate route availability	Safety of diverted traffic	Emergency services provisions	Real-time traffic information	Minimized traffic impacts
1	2	3	4	5	6	7	8	9	10	11	12	13	14	15	16	17	18	19	20	21	22	23	24	25	
Contract Administration																									
CA1—contractor screening							●		●																
CA2—partnering	●	●					●																		
CA3—incentsives-disincentives				●									●		●	●			●		●		●		
CA4—A+B contracting					●										●				●		●				
CA5—lane rental					●									●	●	●			●						
CA6—production-based contract length																									●
Planning—Scheduling																									
PS1—joint schedule review meetings																									●
PS2—accelerated schedule						●									●	●			●	●					●
PS3—detailed hourly schedule					●																				
PS4—dynamic project schedule																									●
PS5—weekend construction														●	●										
PS6—nighttime construction														●	●										
PS7—early utility work completion				●																					
PS8—contingency plan																									●
PS9—responsive adverse weather plan					●																				●
PS10—rest days			●																						
Project Management																									
PM1—daily construction meetings	●	●																							
PM2—effective communication							●																		
PM3—on-site agency decision makers				●																					●
Constructability																									
CO1—formal constructability review				●		●								●											●
CO2—optimization software				●		●								●											●

Figure 2–18. Preliminary strategy selection matrix (Source: Carson et al. 2008)

The secondary strategy selection matrices are detailed matrices focused on the relative benefit of construction, traffic management, and public information (Figure 2–19). The strategy groups, *contract administration*, *planning-scheduling*, *project management*, *constructability*, and *construction practices*, are considered in the secondary strategy selection matrix of construction (Figure 2–19a). The *traffic control* strategy group is considered in the secondary strategy selection matrix of traffic management (Figure 2–19b). The *public relation* strategy group is considered in the secondary strategy selection matrix of public information (Figure 2–19c). The data source of *case studies* was used in these matrices to assess the relative benefit of each strategy for construction, traffic management, or public information activities. The relative benefit is represented in terms of i) low (L), ii) medium (M), or iii) high (H). A blank cell in the matrix is used to represent that there is no relation among the corresponding *strategy* and *relative benefit*.

During the secondary strategy selection stage, highway administrators need to refine the strategies that were selected during the preliminary strategy selection stage. This process requires evaluating the relative benefit of each strategy in terms of low, medium, and high and eliminate the strategy with low (L) relative benefit in all activities. This step will provide highway administrators with the *refined strategies* for the planned pavement rehabilitation project.

Strategy	Relative benefit			
	Communication-coordination	Speed-efficiency	Construction quality	Work zone safety
Contract Administration				
CA1–contractor screening		M		
CA2–partnering	M	L		
CA3–incentives-disincentives	L	H		
CA4–A+B contracting	L	H		
CA5–lane rental	L	H		
CA6–production-based contract length				
Planning–Scheduling				
PS1–joint schedule review meetings	H			
PS2–accelerated schedule		M		
PS3–detailed hourly schedule	M			
PS4–dynamic project schedule		M		
PS5–weekend construction		L	L	
PS6–nighttime construction		L	L	
PS7–early utility work completion		M		
PS8–contingency plan		M		
PS9–responsive adverse weather plan		M		
PS10–rest days				M
Project Management				
PM1–daily construction meetings	H			
PM2–effective communication	M			
PM3–on-site agency decision makers	H	H		
Constructability				
CO1–formal constructability review			M	
CO2–optimization software		M		L
Construction Practices				
CP1–concrete accelerator admixture		M		

(a)

Strategy	Relative benefit				
	Impact reduction	Demand reduction	Work zone traffic flow	Work zone safety	
Traffic Control					
TC1–traffic pattern analysis	M	M			
TC2–alternate route planning		L-H			
TC3–project-special event coordination					
TC4–dynamic traffic control plan	M		M		
TC5–full roadway closures					
TC6–permanent lane closures					
TC7–ramp closures		M	M	M	
TC8–movable concrete barriers			H	L-M	
TC9–speed reductions				L	
TC10–static signs-barrels-barriers			L-M	L	
TC11–changeable message signs		M	M-H	M	
TC12–highway advisory radio			M		
TC13–traffic management center-CCTV			H		
TC14–incident management program				M-H	
TC15–use of local police				M-H	
TC16–business access (signs-flaggers)		H	M	M	
TC17–neighborhood traffic restrictions	M				
TC18–transit incentives-improvements		M			

(b)

Strategy	Relative benefit					
	General traffic	Weekday commuters	Weekend-recreational traffic	Local residents	Local businesses	Truck traffic
Public Relation						
PR1–contracted PR service						
PR2–slogans-logo	M-H					
PR3–elected-community leader buy-in	M					
PR4–ribbon-cutting ceremony		H		H		
PR5–community-public meetings	M-H	M		M	M	
PR6–targeted outreach	H			H	M	M-H
PR7–e-mail-fax database	M				M	
PR8–informational brochures	M			M-H	L-H	L
PR9–media press releases-PSAs	L-H	M	M	H	H	
PR10–telephone hotline						
PR11–website	M					
PR12–billboards	H					
PR13–pre-and post-construction surveys		H	H			

(c)

Figure 2–19. Secondary strategy selection matrix for (a) construction, (b) traffic management, and (c) public information (Source: Carson et al. 2008)

The third decision-support matrix, which is the interdependency matrix, considers the relative level of interdependencies among *all the strategies*. Only a part of the interdependency matrix is shown in Figure 2–20 to illustrate the decision-making process. The interdependency matrix was developed by pair-wise comparison of all strategies and represents the interdependencies as i) low (L), ii) medium (M), or iii) high (H). The data source of *opinions from experts* was used in this matrix to obtain the interdependencies. A blank cell in the matrix is used to represent the pair-wise comparison of the strategies that do not have any interdependency, and the cells with 1 represent the pair-wise comparison of same strategies.

The administrators, during the final step of decision-making process, evaluate the interdependency matrix to identify the strategies that are of high (H) interdependence to the *refined strategies* (from second step). The *identified strategies* may provide additional synergistic benefits if simultaneously applied with the *refined strategies*. Therefore, the *identified strategies* can be included among the *refined strategies* to generate a set of *effective strategies*, which could be implemented during the project (Carson et al. 2008).

Strategy	Relative Level of Interdependence (<u>L</u> ow, <u>M</u> edium, or <u>H</u> igh)															
	CA1	CA2	CA3	CA4	CA5	CA6	PS1	PS2	PS3	PS4	PS5	PS6	PS7	PS8	PS9	PS10
Contract Administration																
CA1–contractor screening	1	H						H		H						
CA2–partnering	H	1						H								
CA3–incentives-disincentives			1	M		M		M								
CA4–A+B contracting			M	1		H		M								
CA5–lane rental					1			M	M							
CA6–production-based contract length			M	H		1		M								
Planning–Scheduling																
PS1–joint schedule review meetings							1	M								
PS2–accelerated schedule	H	H	M	M	M	M	M	1					H	H	H	
PS3–detailed hourly schedule					M				1							
PS4–dynamic project schedule	H									1						
PS5–weekend construction											1					
PS6–nighttime construction												1				
PS7–early utility work completion								H					1			
PS8–contingency plan								H						1		
PS9–responsive adverse weather plan								H							1	
PS10–rest days																1

Figure 2–20. Part of the interdependency matrix (Source: Carson et al. 2008)

The limitations of this model with respect to ABC decision-making are:

- The entire process utilizes qualitative data,
- Access to literature on priorities and potential strategies related to ABC is limited, and
- Access to detailed case studies on ABC with relevant information is limited.

2.7.3 Linear Programming for Decision-Making

Linear programming or linear optimization is a mathematical model used to find an optimal solution for a given objective function with associated constraints. Linear programming is used in many disciplines such as transportation, manufacturing, and telecommunication. The applications include network optimization in transportation and telecommunication industries and production scheduling in manufacturing. The process requires developing a mathematical formulation of each specific problem. The mathematical formulation includes the objective function and its relevant constraints. There are many approaches within the linear programming such as the simplex method, integer linear programming, decision-making, with and without probabilities, and data envelopment analysis. Based on the approach, the objective function is modeled, and the constraints are developed. The formulation is solved to obtain a feasible solution. The feasible solution provides the objective function value for the optimal solution (Anderson et al. 2005). Further, for a situation where the decision is to choose an efficient alternative among many, the data envelopment analysis approach is adopted. In this approach a hypothetical composite alternative is assumed which is composed of all virtuous characteristics of all potential alternatives, and its efficiency is assumed to be unity. The linear programming approach is customized to calculate the efficiency of each alternative and compared with the efficiency of the hypothetical composite alternative. The alternative with efficiency close to *unity* will be the decision alternative (Anderson et al. 2005).

In linear programming, the parameters of the decision alternatives are correlated with the objective function and constraints. This requirement imposes a major limitation when qualitative parameters are involved in the decision-making process.

2.7.4 Scoring Model for Decision-Making

The scoring model is a quick and easy approach to identify an optimal decision alternative from a set of alternatives. The process involves (1) identifying the appropriate parameters, (2) assigning weights to each parameter “*i*” out of 100% (i.e., w_i), (3) assigning a score to each

parameter “*i*” on an ordinal scale with respect to each decision alternative “*j*” (i.e., r_{ij}), and (4) calculating the final score “ S_j ” for each decision alternative “*j*” using Eq.2-1. The decision alternative with the maximum *final score* will be the optimal decision alternative (Anderson et al. 2005).

$$S_j = \sum_i w_i r_{ij} \quad (2-1)$$

El-Diraby and O’Conner (2001) developed a decision-making process using the scoring model, the *Bridge Construction Plan (BCP) evaluation process*. The BCP evaluation process was designed to select an optimal BCP among the appropriate alternatives. The BCP evaluation process is discussed in the following section.

2.7.4.1 Bridge Construction Plan (BCP) Evaluation Process

The BCP evaluation process involves several parameters with six categories of i) safety (S), ii) accessibility (A), iii) carrying capacity (C), iv) schedule (T), v) budget (B), and vi) additional parameters (Q). Then an objective matrix similar to Figure 2–21 can be developed to evaluate the BCPs using the scoring model methodology.

	Safety	Accessibility	Carrying capacity	Schedule	Budget	Other factor(s)	Total
Weights	W_S	W_A	W_C	W_T	W_B	W_Q	100%
BCP #1	S_1	A_1	C_1	T_1	B_1	Q_1	F_1
BCP #2	S_2	A_2	C_2	T_2	B_2	Q_2	F_2
⋮	⋮	⋮	⋮	⋮	⋮	⋮	⋮
BCP #n	S_n	A_n	C_n	T_n	B_n	Q_n	F_n

Figure 2–21 BCP comparison objective matrix (Source: El-Diraby and O’Conner 2001)

The steps that a decision maker needs to follow during a BCP evaluation process include:

1. Assign percentage weights (W_i) to each category. As an example, the “i” represents S, A, C, T, B, and Q categories shown in Figure 2–21. The sum of all the weight is 100% (i.e. $\sum W_i = W_S + W_A + W_C + W_T + W_B + W_Q = 100\%$),
2. Rate the parameters listed under the Safety (S) group using an ordinal scale with respect to BCP#1,
3. Calculate the total of all the parameter ratings listed under the Safety (S) group to obtain a total score value of S_1 ,
4. Repeat steps 2 and 3 for the remaining five groups A, C, T, B, and Q, to obtain the total scores A_1, C_1, T_1, B_1, Q_1 , respectively,
5. Repeat steps 2 to 4 for the remaining BCP alternatives (i.e., BCP#2 to BCP#n), and
6. Finally, calculate the *final score* “ F_j ” (where “j” is 1 to n) using Eq.2-2 for each BCP alternative.

$$F_j = W_S \times S_j + W_A \times A_j + W_C \times C_j + W_T \times T_j + W_B \times B_j + W_Q \times Q_j \quad (2-2)$$

The BCP with the highest final score represents the optimal BCP alternative. The limitations of this model are as follows:

- Multiple decision makers do not have a consistent method to assign weights and preference ratings for each parameter. This may lead to biased results.
- A uniform ordinal scale is not provided for the preference ratings.
- The model does not account for the relative importance of the parameters that are involved in the evaluation process.

2.7.5 Analytic Hierarchy Process (AHP) for Decision-Making

The AHP process enables breaking down a complex, unstructured situation into multi-level hierarchical order by defining major-parameters and sub-parameters for each level.

The first step in AHP is to develop a graphical representation (hierarchy) of a problem in terms of the overall goal, its parameters and the decision alternatives as shown in Figure 2–22. In Figure 2–22 the top level shows the objective, the second level shows the major-parameters, the third level shows the sub-parameters related to each major-parameter, and lowest level shows the decision alternatives.

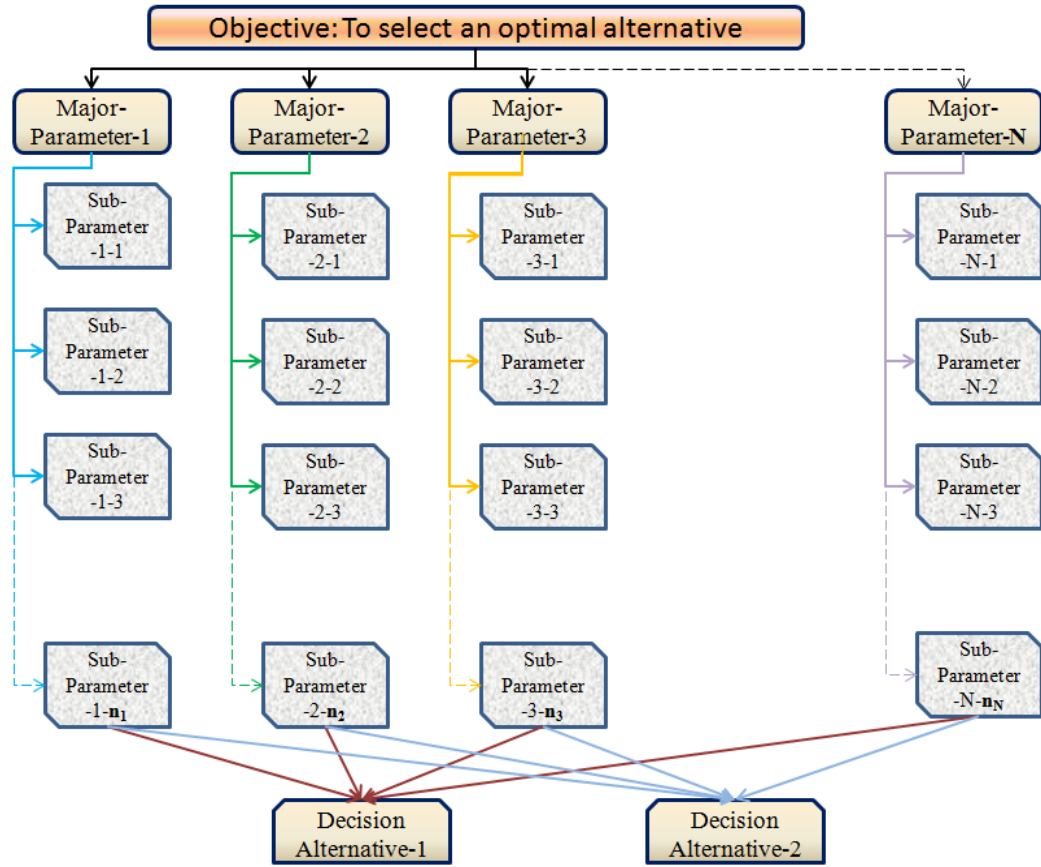

→ Multiple decision alternatives existing for a project are rated against each sub-parameter.

Figure 2–22. Graphical representation of the AHP

The first step is the pair-wise comparison of the major-parameters by assigning a preference rating using a nine-point ordinal scale. Numerical values are assigned to subjective preferences based on the relative importance of each parameter as shown in Table 2-20; this process helps the decision makers to maintain uniform consideration while moving towards a decision. From the major-parameter pair-wise comparison results, a matrix is developed which is described as the pair-wise comparison matrix. The eigenvectors calculated from the pair-wise comparison matrix define the local priorities of the major-parameters (Saaty 1980).

Table 2-20. Fundamental Scale for AHP Pair-Wise Comparison (Source: Saaty 1995)

Rating scale	Definition	Description
9	Extreme importance	The evidence favoring one activity over another is of the highest possible order of affirmation.
7	Very strong or demonstrated importance	An activity is favored very strongly over another; its dominance demonstrated in practice.
5	Strong importance	Experience and judgment strongly favor one activity over another.
3	Moderate importance	Experience and judgment slightly favor one activity over another.
1	Equal importance	Two activities contribute equally to the objective.
2,4,6,8	For compromise between the above values	Sometimes one needs to interpolate a compromise judgment numerically because there is no good word to describe it.
Reciprocals of above	If activity 'i' has one of the above nonzero numbers assigned to it when compared with activity 'j,' then 'j' has the reciprocal value when compared with 'i.'	A comparison mandated by choosing the smaller element as the unit to estimate the larger one as a multiple of that unit.

Next, a pair-wise comparison of the sub-parameters of each major-parameter is performed, again using the ordinal scale shown in Table 2-20. Pair-wise comparison matrices are developed for all the sub-parameters under the same major-parameter. Then local priorities are obtained for the pair-wise comparison matrices of sub-parameters by calculating the corresponding eigenvectors. Finally, relative preferences of the decision alternatives with respect to each sub-parameter are obtained. A third set of pair-wise comparison matrices are developed in which each matrix corresponds to the pair-wise comparison of decision

alternatives with respect to each sub-parameter. The local priorities are obtained by calculating the corresponding eigenvectors. The three sets of the local priorities, that are: i) local priorities of the major-parameters, ii) local priorities of the sub-parameters, and iii) local priorities of the decision alternatives with respect to each sub-parameter, are finally integrated using AHP formulation to calculate the final *priority* of each decision alternative. The decision alternative with the highest *priority* will be the optimal solution (Saaty 1980). This process allows incorporating both qualitative and quantitative parameters into the decision-making process. An example implementation of the AHP was completed by Moghadam et al. (2009), which was *the decision-making in selecting container yard operating equipment*. This decision-making process is discussed in the following section.

2.7.5.1 *Decision-Making in Selection of a Container Yard Operating Equipment*

The decision-making process for selecting the best container yard operating equipment utilized the AHP process (Moghadam et al. 2009). Five components of AHP which provided an ideal platform for this problem were i) finite set of options, ii) trade-offs between parameters, iii) heterogeneity of qualitative and quantitative parameters, iv) matrix of pair-wise comparisons, and v) the decision matrix. The AHP methodology was applied to find the best container yard operating equipment among the *selection options*, which were (1) semi-automated straddle carriers (SC), (2) rubber tired gantry cranes (RTG), and (3) automated and semi-automated rail mounted gantry cranes (RMG).

Many significant parameters for decision-making were identified for this problem. The major-parameters and their associated sub-parameters were organized in a container yard handling equipment decision tree as shown in Figure 2–23. The sub-parameters which were both qualitative and quantitative were brought under one category by using the AHP scale of 1 to 9 (Table 2-20). The preference ratings from the experts were collected following the three-step procedure of AHP (discussed in the previous section). The final priorities of the *selection candidates* were obtained by integrating the preference values of all the parameters and the *selection candidates* through the AHP formulation. The study concluded that RMG system was the optimal alternative.

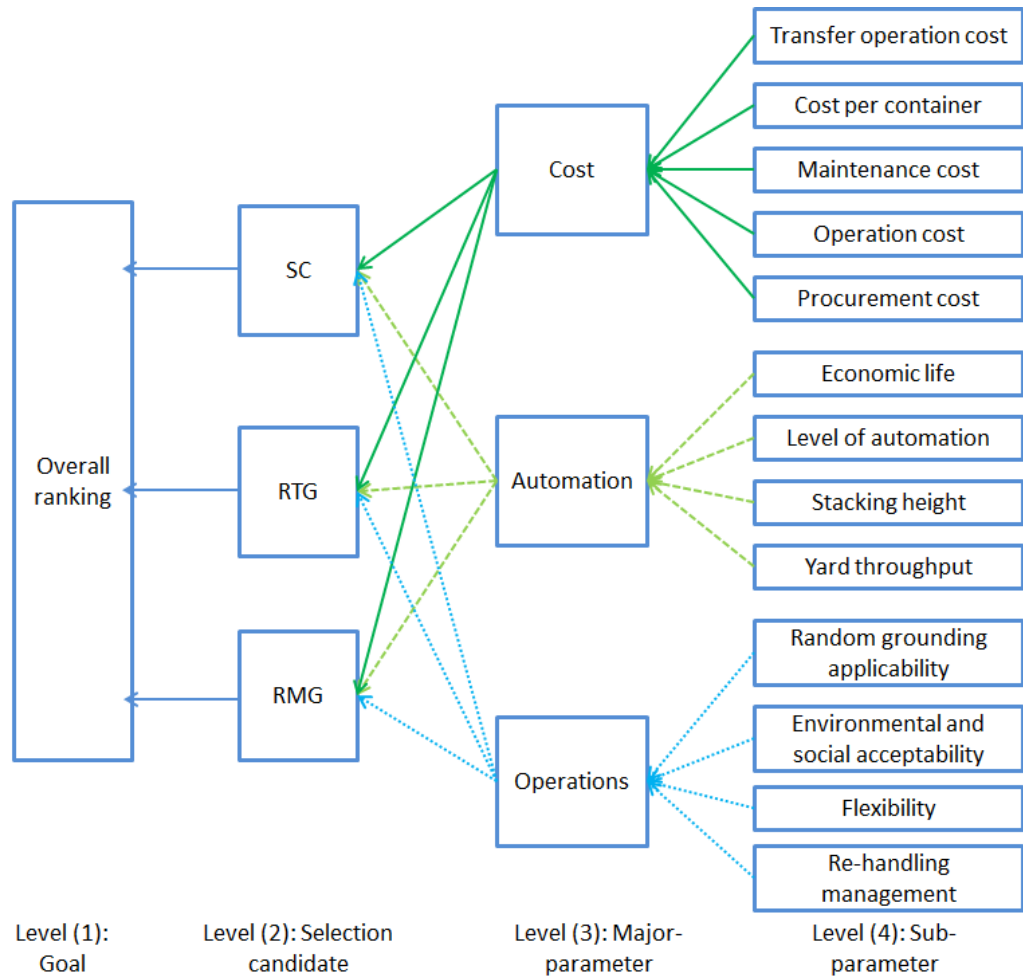

Figure 2–23. Container yard handling system decision tree (Source: Moghadam et al. 2009)

The advantages of AHP are these:

- Both qualitative and quantitative evaluation procedures can be incorporated with a constant rating scale.
- Provides consistency to the decisions from multiple decision makers.
- Uses an ordinal scale to represent qualitative judgments and priorities are calculated through a mathematical process (eigenvector).
- AHP can incorporate both qualitative and quantitative parameters in the decision-making process.
- Finally, the method has been used in various disciplines and in different formats; hence, it is a tested and validated.

The limitations of AHP are these:

- The process is time consuming when the number of parameters is large.
- Processing manual AHP evaluation requires keeping track of AHP formulation as well as the consistency ratio which is reported as tedious.
- For higher order matrices (i.e., large number of major-parameters or sub-parameters), consistency in the experts judgments may be difficult to achieve. This is because the number of transitive rules to be satisfied is proportional to matrix rank square. Therefore, priority calculation methods without *the computing aid* will be impractical (Tam et al. 2006; Buckley et al. 2000; Moghadam et al. 2009).

2.7.6 Multi-Criteria Decision-Making Approach for Highway Slope Hazard Management

A linguistic fuzzy theory is a category of the multi-criteria decision-making procedure. This procedure was used to establish the hazard level associated with each hazard assessment criteria for managing *potential* highway slope failures in Ohio. In fuzzy set theory, the expert preference is expressed by a quantitative value by using a membership function [$\mu_A(x)$] that takes a real value between 0 and 1 (Zadeh 1965; Liang and Pensomboon 2010). The fuzzy approach can be evaluated with triangular fuzzy numbers and trapezoidal fuzzy numbers. This process will derive fuzzy weights from group evaluations, the max-min aggregation and center-of-gravity defuzzification. The process proceeds in parallel with AHP with a difference of incorporating fuzzy mathematical calculations. As in the AHP, preference ratings are provided on a fixed scale of 1 to 9. In the fuzzy approach, the ratings are provided with respect to fuzzy set theory as shown in Eq.2-3. The perspective of the membership functions and linguistic values used is shown in Figure 2–24. Six hazard assessment criteria identified from the literature were considered for this study. The hazard assessment criteria includes: i) slope failure location and its impact on highway safety, ii) extent of pavement damage due to the slope movement, iii) the maintenance response requirement due to slope movement, iv) Decision Sight Distance (DSD), which is the ratio of the actual sight distance to American Association of State Highway and Transportation Officials (AASHTO) standard sight distance, v) Average Daily Traffic (ADT) which is the average number of vehicles passing a landslide location per day, and vi) slope displacement magnitude.

The first three criteria require judgment from the assessor, whereas, the remaining three criteria can be measured directly. Linear optimization is carried out to obtain the decision value (D) based on hazard assessment criteria (Eq.2-4). The slope failure sites with higher decision value will be those requiring corrective activities with a higher priority (Liang and Pensomboon 2010).

$$\text{Fuzzy set } A = \{[x, \mu_A(x)]\}, x \in X \quad (2-3)$$

$$D = \max (D^p_m) \quad (2-4)$$

where:

$[\mu_A(x)]$ is the membership function which takes value between 0 and 1.

D^p_m is the sum of 'm' membership function averages for 'p' criteria.

The limitations of this model are

- There is difficulty involved in intricate mathematical calculations.
- The manual version of evaluation is tedious, and programming in a computer structure is time consuming and costly.

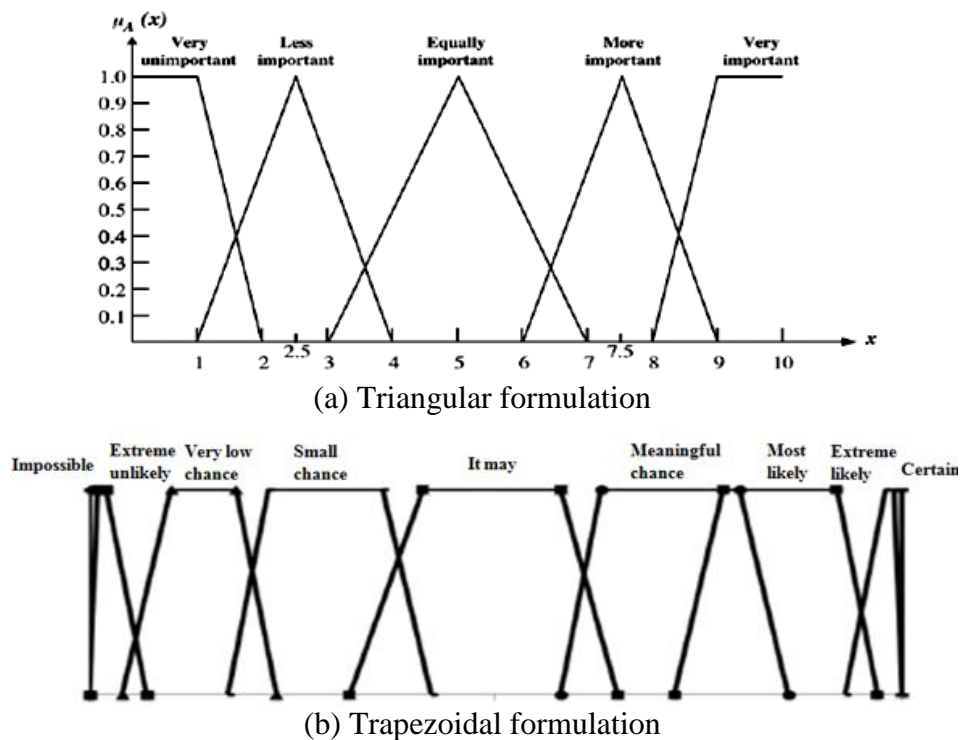

Figure 2–24. Membership functions and linguistic values (Source: Liang and Pensomboon 2010)

2.7.7 Application of the AHP to Select Project Scope for Video-Logging and Pavement Condition Data Collection

Highway video-logging involves the use of electronic equipment mounted in a large van at highway speed for capturing a range of accelerations, laser measurements, digital imagery, and precise positioning (Larson and Forman 2007). Virginia DOT's asset management division obtained support from executive management to expand video-logging and pavement data collection statewide. This required an optimal number of highway miles to be covered annually for video-logging. The division considered few approaches in deciding the annual mileage of highway logging, which were i) collecting data on all hard-surfaced roads every year, ii) collecting only what is needed for supporting pavement maintenance and ignoring the right-of-way images. To arrive at an optimal strategy, Virginia DOT used AHP to formalize the decision process and 'Expert Choice' economic modeling software to assist AHP evaluation process. The AHP decision tree was formulated by considering distinct aspects as well as difficulties of each alternative. The aspects were organized into hierarchical levels such that the aspects with greater influence were classified into objectives (the first level of the hierarchy) and their respective sub-objectives (the second level of the hierarchy), while those with low influence were classified into objectives in general (the first level of the hierarchy) (Larson and Forman 2007). A schematic view of the decision tree from the Expert Choice economic modeling software is shown in Figure 2–25.

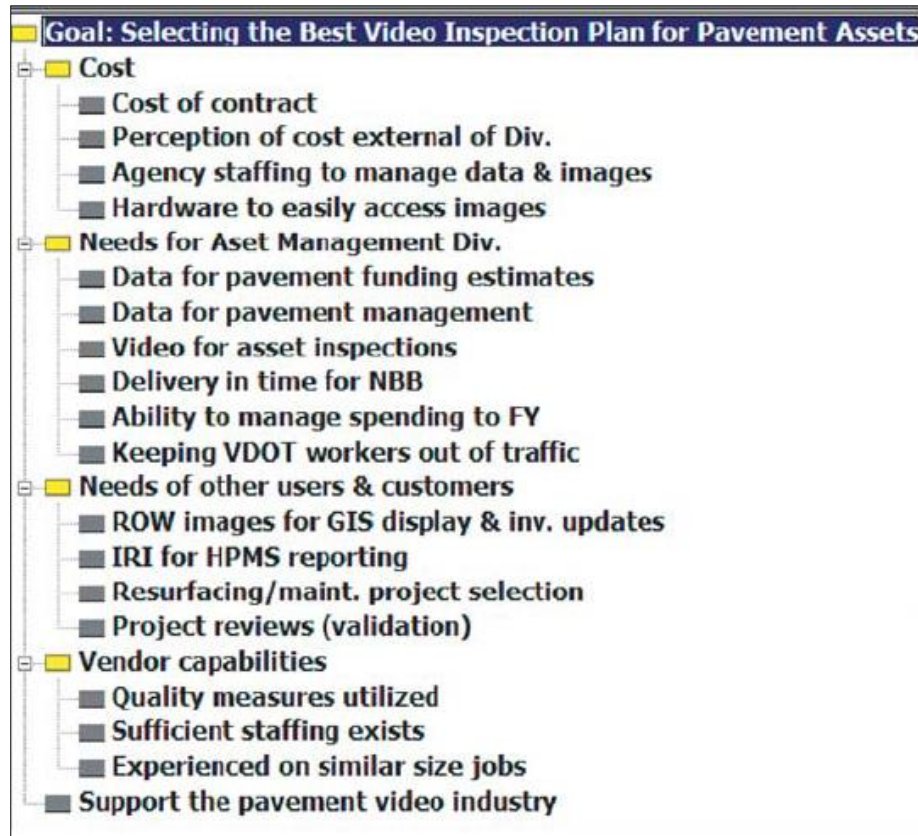

Figure 2–25. Decision tree from expert choice software (Source: Larson and Forman 2007)

The initial task was limited to pavement data collection. Thus, the decision goal was to select the best video inspection plan for pavement assets. Five alternatives were identified as i) perform video-logging for all pavements every year, ii) perform video-logging for interstate, primary, and one-third of secondary highways every year, iii) perform video-logging for interstate and one-third of secondary highways every year and all primary highways every two years, iv) perform video-logging for interstate, primary, and one-fifth of secondary highways every year, and v) perform video-logging for only interstate and primary highways every year (Larson and Forman 2007).

The preliminary AHP evaluation was performed with only first four alternatives, and the optimal alternative was - (i) *performing video-logging for all pavements*. This alternative was not feasible; thus, a sensitivity analysis of the alternatives was performed. The sensitivity analysis results (Figure 2–26) revealed that alternative-(i) is diverging significantly from other alternatives. For that reason a fifth alternative was added to expand the range of preferences. The preferred alternative selected from the modified AHP was alternative-(iv) *performing*

video-logging for interstate, primary, and one-fifth of secondary highways every year. The inference from this model is that there is a need for precision and computing tools to obtain desired consistency in the results, and sensitivity analysis is a virtuous technique to validate the obtained results.

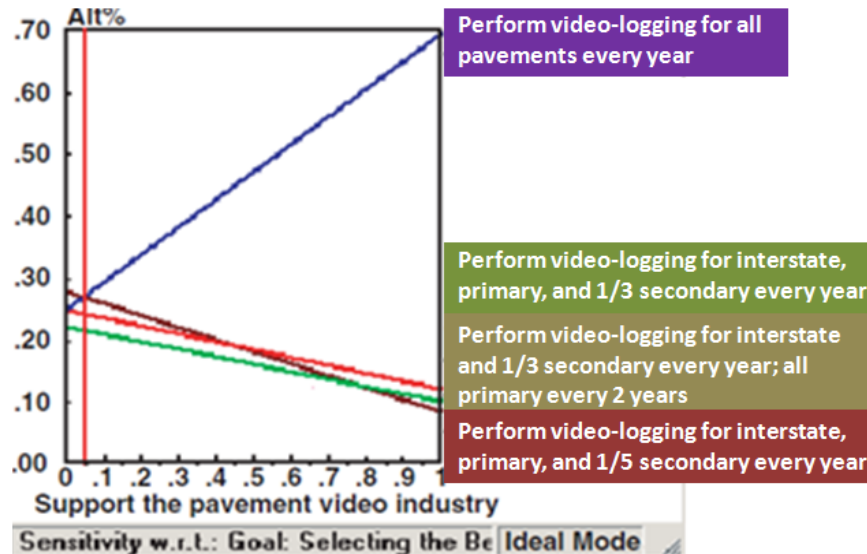

Figure 2–26. Sensitivity analysis results for corresponding alternatives from expert choice software (Source: Larson and Forman 2007)

2.7.8 Accelerated Construction Decision-Making Process for Bridges

Salem and Miller (2006) developed a decision-making model to identify the best construction procedure for a given bridge construction site. This study was funded by the Ohio DOT and the U.S. DOT. In the model, the potential of each construction strategy for achieving the goal is evaluated with respect to parameters of Cost (C), Traffic flow (T), Safety (S), Economic parameter (B), Social parameter (P) and Environmental parameter (E). These parameters were considered as major-parameters and consisted of sub-parameters. The data required for this decision-making model was obtained from a survey of 25 U.S. DOTs and industry experts with accelerated bridge construction expertise. The survey asked the share of each of six major-parameters in the accelerated construction decision-making. The survey data was averaged with 95% confidence intervals to obtain mean percentages for each parameter as shown in (Table 2-21). Similarly, the sub-parameters were assigned mean percentages.

Table 2-21. Mean Weights of Parameters from the Survey (Source: Salem and Miller 2006)

Parameter	Confidence interval (95%)	Mean percentage weight
Cost	16-31	25
Traffic flow	11-29	20
Safety	11-31	20
Economy	8-18	15
Social	7-16	10
Environment	7-13	10
Total		100

The mean percentage weights from major- and sub-parameters were back-calculated to form pair-wise comparison matrices of AHP (Table 2-22). Local priorities of major- and sub-parameters were then calculated, and each construction alternative was evaluated for its effectiveness: “e” with respect to each sub-parameter (Figure 2–27). The effectiveness was then multiplied with the mean percentage weights to calculate final priorities of construction alternatives (Figure 2–27).

Table 2-22. AHP Pair-Wise Comparison Matrix Developed through Back-Calculation from Mean Percentage Weights (Source: Salem and Miller 2006)

Pair-wise comparisons	Cost	Traffic flow	Safety	Economy	Social	Environmental
Cost	1	3/1	3/1	4/1	4/1	5/1
Traffic flow	1/3	1	1	3/1	4/1	4/1
Safety	1/3	1	1	3/1	4/1	4/1
Economy	1/4	1/3	1/3	1	3/1	3/1
Social	1/4	1/4	1/4	1/3	1	1
Environmental	1/5	1/4	1/4	1/3	1	1

$$\begin{array}{l}
 \text{Alternative x} \\
 \text{Alternative y} \\
 \text{Alternative z}
 \end{array}
 \begin{bmatrix}
 e_{1x} & e_{2x} & e_{3x} & e_{4x} & e_{5x} \\
 e_{1y} & e_{2y} & e_{3y} & e_{4y} & e_{5y} \\
 e_{1z} & e_{2z} & e_{3z} & e_{4z} & e_{5z}
 \end{bmatrix}
 \begin{bmatrix}
 w_1 \\
 w_2 \\
 w_3 \\
 w_4 \\
 w_5
 \end{bmatrix}$$

Figure 2–27. Final evaluation of construction alternatives (Source: Salem and Miller 2006)

The limitations of this model are these:

- The model is not capable of adequately in addressing specific sub-parameters which can further affect the final decision.
- The pair-wise comparison matrices are not developed directly from expert opinions; rather pair-wise comparison matrices are formed by back-calculating the survey data percentages. Thus, the capabilities of the AHP are not effectively implemented in this decision-making model.

2.7.9 PBES Decision-Making Model

Implementation of innovative bridge systems and construction technologies requires addressing many variables. These are the applicability of the design, availability of skilled workforce (i.e., contractors' and suppliers' abilities to deliver a successful project), project site access and space for equipment placement, the effect of construction process on cost and schedule, the owner's contractor's willingness to share responsibility and risk, and commitment of all the parties to successful completion of the project. Ralls (2005) developed a model addressing these variables to evaluate the potential and effectiveness of using an ABC for a particular site. This model consists of three main sections: a flow chart (Figure 2–28), a matrix (Table 2-23), and a considerations section. The flowchart is a tool that provides an overview of parameters that need to be considered in decision-making. The matrix of the questionnaire consists of detail questions requiring selection of *Yes/No/Maybe* answers. The dominance of a type of answer determines the optimal construction alternative. The questions presented in the matrix are all focused on ABC. For example, if *Yes* is dominant, then the site is feasible for ABC. The last part of this model, the *considerations section*, includes parameter descriptions in detail along with various definitions. Further details can be obtained from the report *Prefabricated Bridge Elements and Systems Decision-Making* by Ralls (2005).

The three sections in this model can be used independently or jointly, depending on the desired depth of evaluation. Even though the flowchart helps in arriving at the decision, the relative importance of different parameters is not considered. The matrix refers to the questionnaire having its implications for some tangible parameters and suggests answering the questionnaire. This is not that different from assigning random importance to parameters. This approach is

not quantitative and lacks a process to allow further refinements of the decision (Salem and Miller 2006).

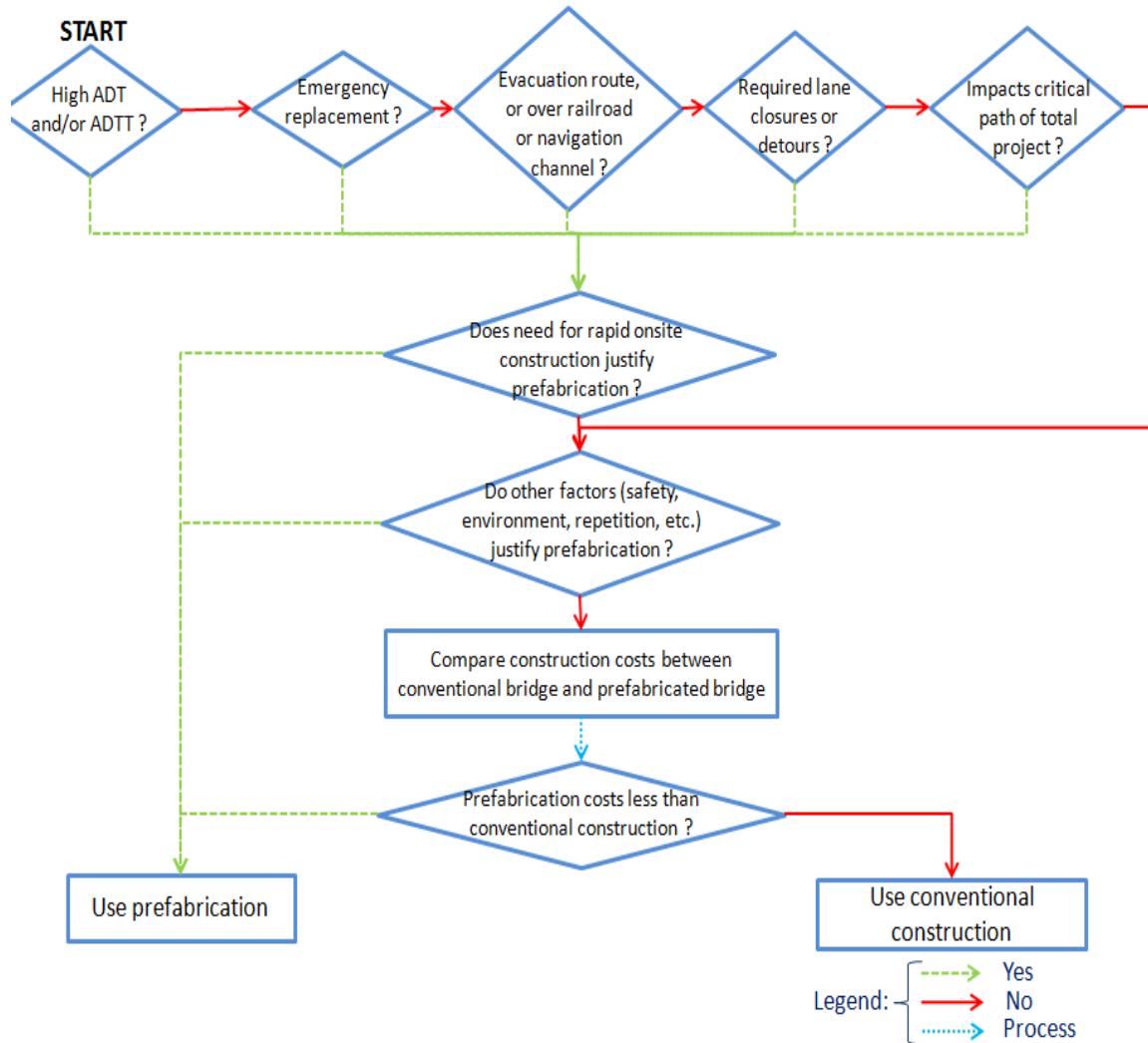

Figure 2–28. Flowchart for high-level decision-making on PBES (Source: Ralls 2005)

Table 2-23. Matrix for High-Level Decision-Making on PBES (Source: Ralls 2005)

Question	Yes	Maybe	No
Does the bridge have high average daily traffic (ADT) or average daily truck traffic (ADTT) or is it over an existing high-traffic-volume highway?			
Is the bridge over a railroad or navigable waterway, or is it on an emergency evacuation route?			
Will traffic be subject to back-ups when using the bridge during construction, or be subject to excessive detours during construction of the bridge?			
Is this project an emergency bridge replacement?			
Must traffic flow be maintained on the bridge during construction?			
Can the bridge be closed during off-peak traffic periods, e.g., nights and weekends?			
Does the bridge have multiple identical spans?			
Can the bridge be grouped with other bridges for economy of scale?			
Will roadway construction activities away from the bridge be completed quickly enough to make rapid installation of prefabricated bridge a cost effective solution?			
Can adequate time be allocated from project award to site installation to allow for prefabrication of components to occur concurrently with site preparation?			
Do worker safety concerns at the site limit conventional methods e.g., adjacent power lines or over water?			
Is the site in an environmentally sensitive area requiring minimum disruption (e.g., wetlands, air quality, noise, etc.)?			
Is the bridge location subject to construction time restrictions due to adverse economic impact?			
Are there natural or endangered species at the bridge site that necessitate short construction time windows or suspension of work for a significant time period, e.g., fish passage or peregrine falcon nesting?			
If the bridge is on or eligible for the national register of historic places, is prefabrication feasible for replacement/rehabilitation per the memorandum of agreement?			
Is the bridge site accessible for delivery of prefabricated components or use of heavy lifting equipment?			
Does the location of the bridge site create problems for delivery of ready-mix concrete?			
Does the local weather limit the time of year when cast-in-place construction is practical?			
Does the height of substructures make use of formwork to construct them inconvenient or impractical?			
Are fabricators available to economically manufacture and deliver the required prefabricated components?			
Are there contractors available in the area with sufficient skill and experience to perform prefabricated bridge construction?			
Does the height of the bridge above ground make false work uneconomical or impractical?			
Totals:			

2.7.10 Utah DOT ABC Decision-Making Process

UDOT developed a model which is an extended version of the PBES model developed by Ralls (2005). The flowchart by Ralls (2005) (Figure 2–29) was modified by incorporating additional parameters. The *Yes/No* option selection was retained. Selecting one *Yes* choice on a critical parameter can lead to ABC implementation decision. Again, in this procedure, quantitative and informed judgment as to the relative importance of parameters was absent. To overcome this, UDOT in 2010 developed a scoring table with a modified flowchart (UDOT 2010a). In this new model, the mathematical method of *scoring model* was utilized.

UDOT, in their decision-making model, focused on only one set of parameters rather than grouping as major-parameters and sub-parameters. The parameters were divided into site specific options with an ordinal scale of 0 to 5 (Table 2-24). Predefined weights were assigned to each parameter (Table 2-25, column b). For ABC decision evaluation, for a specific site, the site specific options will be assigned values depending on the site characteristics. The values entered by experts are multiplied with predefined weights and then summed to obtain a total score (Table 2-25, column c). This total score, with a maximum score (Table 2-25, column e), is assigned as the ABC rating (Eq.2-5). Finally, the ABC rating is used in the modified flowchart (Figure 2–30) for the final decision.

$$\text{ABC rating} = \frac{\text{Total score}}{\text{Maximum score}} \times 100 \quad (2-5)$$

Even though the UDOT procedure is an improvement to the PBES decision-making model, adequate descriptions for the predefined weights are not provided (Table 2-25, column b). The process is not flexible; thus project specific features cannot be addressed. Some tangible parameters, which will have a greater impact on the decision, are not included (e.g., impact on surrounding communities, contractor or precast plant experience, etc.). Moreover, in the modified flowchart, the decision box “Administrative decision by region/PD directors” is not clearly described. This decision box may switch the decision even when the rating for a construction alternative is within *0 to 20* (Figure 2–30).

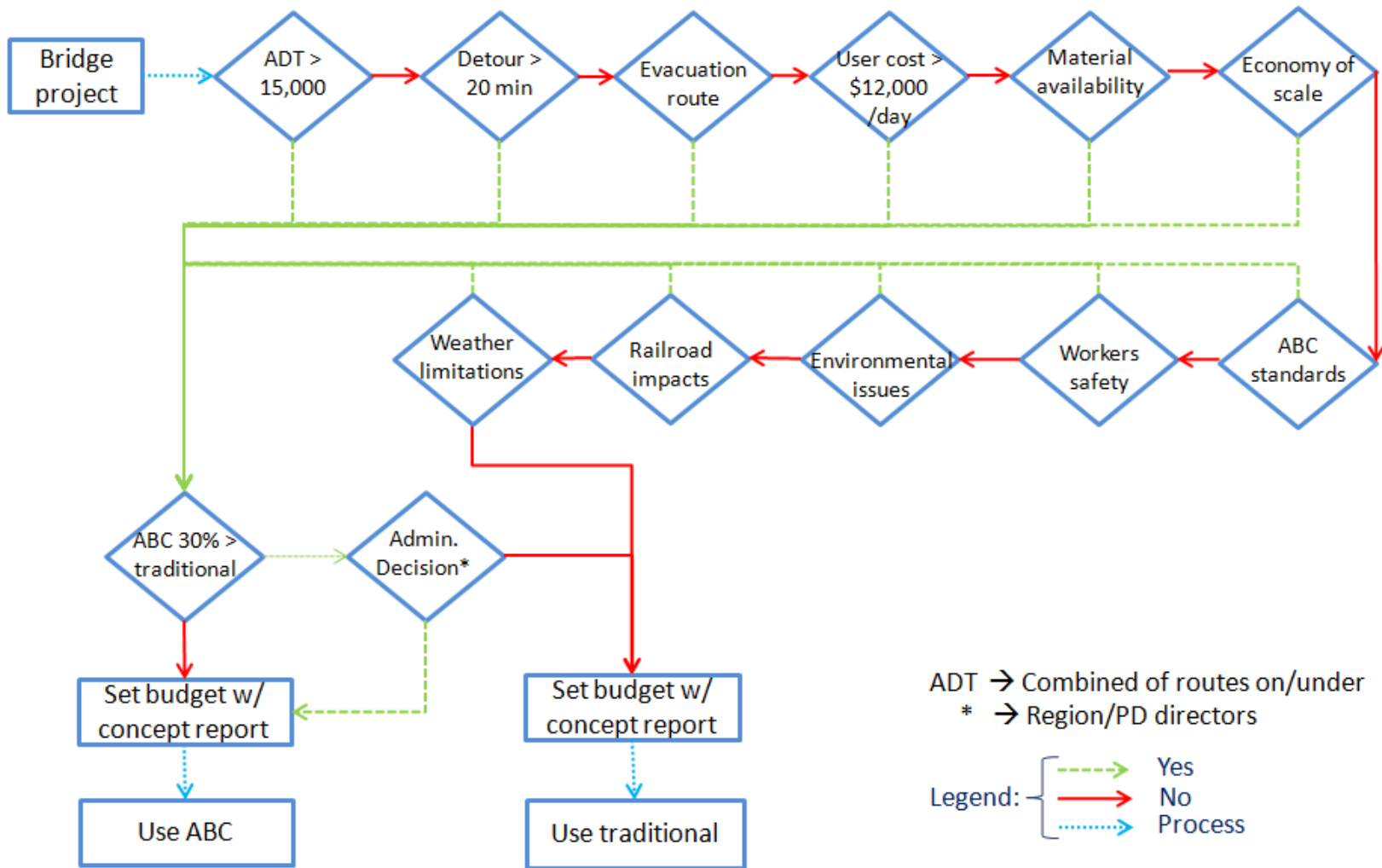

Figure 2–29. UDOT ABC decision chart (Source: Ralls 2008)

Table 2-24. UDOT ABC Scoring Sheet (Source: UDOT 2010a)

ABC rating procedure: Enter values for each aspect of the project. Attach back-up data if applicable			
Average daily traffic	X1	0	No traffic impacts
Combined on and under		1	Less than 5000
Enter 5 for Interstate Highways		2	5000 to 10000
		3	10000 to 15000
		4	15000 to 20000
		5	More than 20000
Delay time	X2	0	No delays
		1	Less than 5 minutes
		2	5-10 minutes
		3	10-15 minutes
		4	15-20 minutes
		5	More than 20 minutes
Bridge classification	X3	1	Normal Bridge
		3	Essential Bridge
		5	Critical Bridge
User costs	X4	0	No user costs
		1	Less than \$10,000
		2	\$10,000 to \$50,000
		3	\$50,000 to \$75,000
		4	\$75,000 to \$100,000
		5	More than \$100,000
Economy of scale	X5	0	1 span
(total number of spans)		1	2 to 3 spans
		2	4 to 5 spans
		3	More than 5 spans
Etc.		

Table 2-25. Total Score Calculation of UDOT ABC Parameters (Source: UDOT 2010a)

Parameter	Score (a)	Weight (b)	Adjusted score (c)	Maximum score (d)	Maximum adjusted score (e)
Average daily traffic	X1	10	X1 * 10	5	50
Delay time	X2	10	X2 * 10	5	50
Bridge classification	X3	4	X3*4	5	20
User costs	X4	10	X4*10	5	50
Economy of scale	X5	3	X5*3	3	9
Use of typical details	X6	3	X6*3	5	15
Safety	X7	8	X7*8	5	40
Railroad impacts	X8	5	X8*5	5	25
Weather limitations	X9	3	X9*3	5	15
			Total score = Σ		Max. score = 274

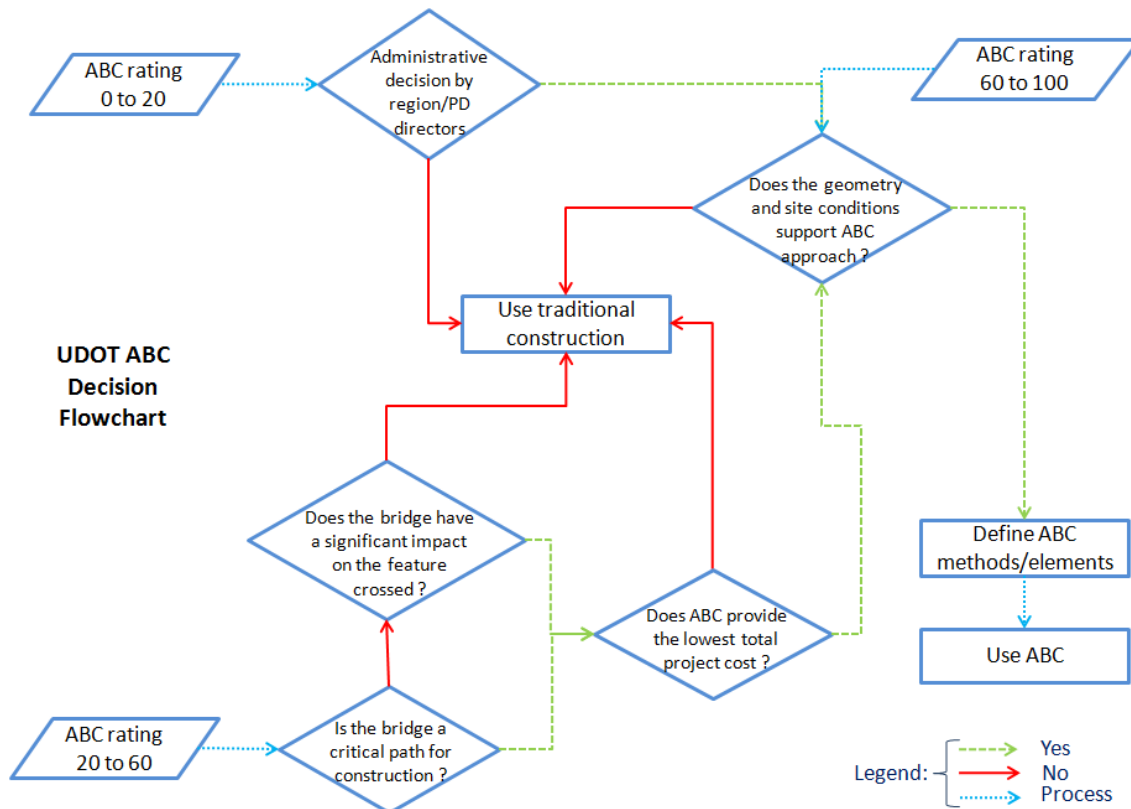

Figure 2–30. Modified UDOT ABC decision chart (Source: UDOT 2010a)

2.7.11 A Planning Phase Decision-Making Software for ABC

The decision-making software, which was developed by Doolen (2011) under the FHWA-sponsored pool fund study, considers relative appraisal of ABC parameters. This decision-making software utilizes AHP to quantify the qualitative trade-offs between the parameters to calculate the overall priority of respective construction alternatives. The decision-making platform is formally known as the *AHP decision-making environment*. It is developed in a Microsoft Visual Studio.NET application to evaluate between conventional and ABC alternatives.

The parameters (criteria) for this decision-making platform are gathered from interviews with various State Department of Transportation officials. The parameters are grouped into 5 major-parameters and associated sub-parameters. These parameters are arranged in a hierarchical format (Figure 2–31). The platform allows customization of major-parameters and sub-parameters with respect to the site specific conditions. The graphical user interface allows users to navigate between four tabs (Figure 2–32) which are i) decision hierarchy, ii) pair-wise comparison, iii) results, and iv) cost weighted analysis. The three major steps are accessed by the first two tabs. In the first tab, the user has the option to add or delete sub-parameters (Figure 2–32). In the second tab, pair-wise comparison of the major-parameters, sub-parameters, and construction alternatives are performed qualitatively on a fixed ordinal scale of 1 to 9 (Figure 2–33). The pair-wise comparison matrices are generated and evaluated to calculate the local priorities using the *approximate method* developed by Saaty (1980). The *approximate method* involves forming normalized matrices from the pair-wise comparison matrices. Then each element of the normalized matrix is divided by a corresponding column total to form a resultant matrix. The rows of that resultant matrix are averaged to obtain the local priorities. A similar procedure is performed for all three steps of analysis. The final priority values of the construction alternatives are obtained after integrating local priorities from the three AHP steps. The construction alternative with highest priority will be the preferred one.

This *AHP decision-making platform* is developed to be used by a single user at a time (Doolen 2011). In the case of multiple users, each has to execute the program separately, and discuss the choice with each other without a defined process.

The AHP calculates priority values for the alternatives. These priority values may change significantly with slight deviations in major-parameters' or sub-parameters' preferences. To account for this inconsistency, sensitivity analysis is recommended by Forman and Selly (2000). The *ABC decision-making platform* does not address the sensitivity analysis. Generally, sensitivity analysis for any AHP evaluation is performed by varying one parameter preference, without changing other parameter preference ratings from their actual values. The sensitivity analysis can be performed by evaluating the process for multiple trials. In each trial, preference of parameters are varied (major-parameter and sub-parameter) independently. The results, when plotted on a bar chart, will show the sensitivity of priority value of alternatives with respect to each parameter (major-parameter or sub-parameter).

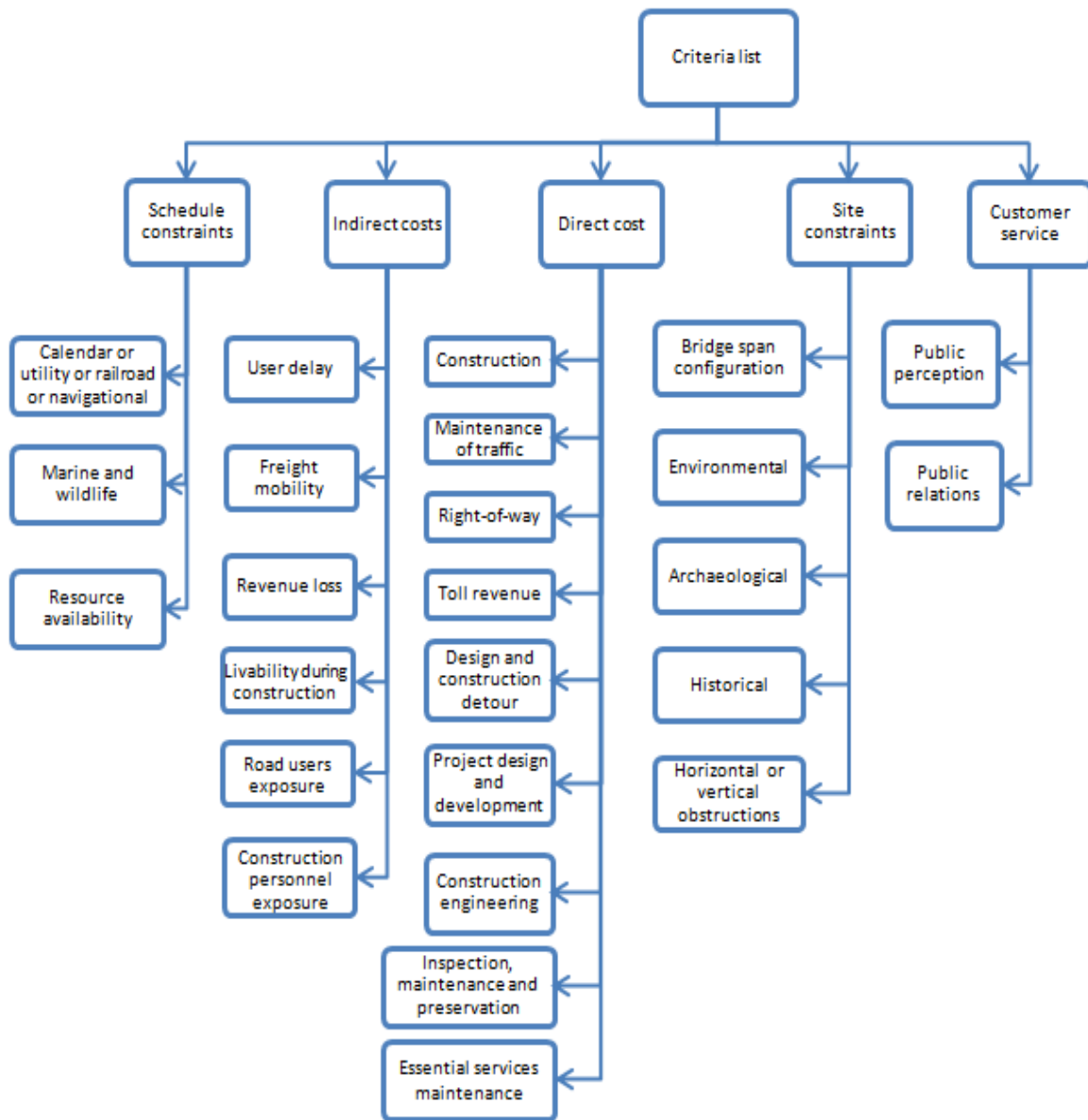

Figure 2–31. Default criteria hierarchy of the AHP decision-making software (Source: Doolen 2011)

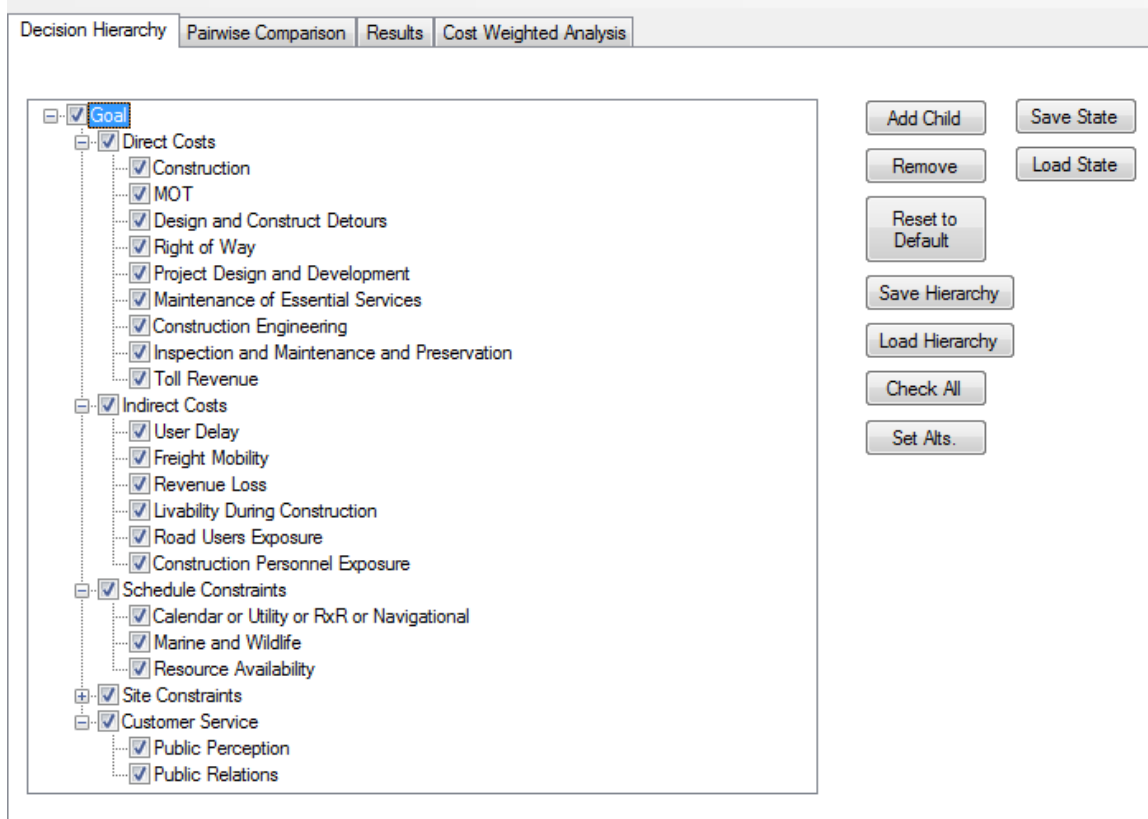

Figure 2–32. Graphical user interface of the AHP decision-making software (Source: Doolen 2011)

Decision Hierarchy	Pairwise Comparison	Results	Cost Weighted Analysis
Construction	<input type="radio"/> 9 <input type="radio"/> 7 <input type="radio"/> 5 <input type="radio"/> 3 <input type="radio"/> 1 <input type="radio"/> 3 <input type="radio"/> 5 <input type="radio"/> 7 <input type="radio"/> 9	MOT	<input type="text"/>
Construction	<input type="radio"/> 9 <input type="radio"/> 7 <input type="radio"/> 5 <input type="radio"/> 3 <input type="radio"/> 1 <input type="radio"/> 3 <input type="radio"/> 5 <input type="radio"/> 7 <input type="radio"/> 9	Design and Construct Detours	<input type="text"/>
Construction	<input type="radio"/> 9 <input type="radio"/> 7 <input type="radio"/> 5 <input type="radio"/> 3 <input type="radio"/> 1 <input type="radio"/> 3 <input type="radio"/> 5 <input type="radio"/> 7 <input type="radio"/> 9	Right of Way	<input type="text"/>
Construction	<input type="radio"/> 9 <input type="radio"/> 7 <input type="radio"/> 5 <input type="radio"/> 3 <input type="radio"/> 1 <input type="radio"/> 3 <input type="radio"/> 5 <input type="radio"/> 7 <input type="radio"/> 9	Project Design and Development	<input type="text"/>
Construction	<input type="radio"/> 9 <input type="radio"/> 7 <input type="radio"/> 5 <input type="radio"/> 3 <input type="radio"/> 1 <input type="radio"/> 3 <input type="radio"/> 5 <input type="radio"/> 7 <input type="radio"/> 9	Maintenance of Essential Services	<input type="text"/>
Construction	<input type="radio"/> 9 <input type="radio"/> 7 <input type="radio"/> 5 <input type="radio"/> 3 <input type="radio"/> 1 <input type="radio"/> 3 <input type="radio"/> 5 <input type="radio"/> 7 <input type="radio"/> 9	Construction Engineering	<input type="text"/>
Construction	<input type="radio"/> 9 <input type="radio"/> 7 <input type="radio"/> 5 <input type="radio"/> 3 <input type="radio"/> 1 <input type="radio"/> 3 <input type="radio"/> 5 <input type="radio"/> 7 <input type="radio"/> 9	Inspection and Maintenance and Preservation	<input type="text"/>

Figure 2–33. Qualitative pair-wise comparisons in AHP decision-making software (Source: Doolen 2011)

ABC decision making platform utilizing AHP is superior to the previously discussed models. Sensitivity analysis was performed for its validation using a prototype bridge site. The *decision making platform* was used to evaluate among the alternatives viz., conventional cast-in-place construction (CIP) and ABC. Major-parameters were identified as duration, environment, safety, site condition, traffic, and cost. These major-parameters included several sub-parameters. In the example, the site was assumed to be in a rural with low traffic volume of both facility carried and feature intersected (i.e., for sensitivity analysis with respect to the *Traffic* parameter). Generally, the major-parameters are pair-wise compared and assigned a preference rating based on the expert's experience and knowledge; whereas the sub-parameters are pair-wise compared and assigned a preference rating with respect to site specific conditions. To perform the sensitivity analysis the major-parameters were assigned equal preference ratings (Figure 2–34, no.1); whereas the sub-parameters were assigned preference ratings with respect to the site specific conditions (Figure 2–34, no.2). Most of the sub-parameters such as low ADT, short detour length, and low significance of the Level of Service (LOS) are biased towards conventional cast-in-place construction in the decision making process. Finally, *platform* was executed for evaluation, and the results showed that the ABC alternative is preferred (Figure 2–34, no.3). The analysis of the results show that; i) ABC is governed for a site in a rural area with low ADT, short detour length, and low significance of LOS, which seems an unlikely preference, and ii) although the sub-parameters have different local priorities (Figure 2–34, no. 2), the results show constant values of each alternative under all major-parameters (in Figure 2–34, no. 4 red circle mark). This cannot be correct, because for AHP calculation the values in Figure 2–34 no.4 should be calculated by integrating the major-parameter local priorities with their sub-parameter local priorities.

Further, the sensitivity plot for this analysis is generated by altering ratings only for the *ADT sub-parameter* (Figure 2–35). The sensitivity plot shows that the decision alternatives (i.e., conventional CIP and ABC) have equal values for each major-parameter. This cannot be correct because the major-parameter preference ratings are kept constant while the sub-parameter preference ratings are changed. The red and blue lines in Figure 2–35 showing the decision alternatives having equal weight corresponding to each major parameter should take different values because of different sup-parameter preference ratings. This error is the result

of *decision-making software* not checking the consistency ratio, while the local priorities are calculated using the approximate method.

Therefore the drawbacks pertaining in this *decision making procedure* are as follows:

- Project specific data are not provided to the user during pair-wise comparison, leaving users to rely upon their choices without any supportive information (i.e., if the user has access to quantitative data on the parameters, then preference ratings will be more consistent).
- The failure in addressing the consistency ratio generates erroneous results (as shown by the sensitivity analysis of an example site). This is because multiple sub-parameters increases the number of pair-wise comparisons, thus the rank of the pair-wise comparison matrix. As mentioned by Saaty (1980), more variables in the pair-wise comparisons create consistency issues when the approximate method is used for calculating local priorities. A consistency ratio of less than 10% is required or the pair-wise comparisons should be balanced (Saaty 1995).
- As complete understanding of the project and related data is impractical to be obtained from a single source; a negotiation process among multiple decision makers will improve the accuracy of the final decision. The *platform* does not facilitate incorporating decisions from multiple decision makers.
- Incorporating further automation in the preference rating process will increase the consistency of the process.

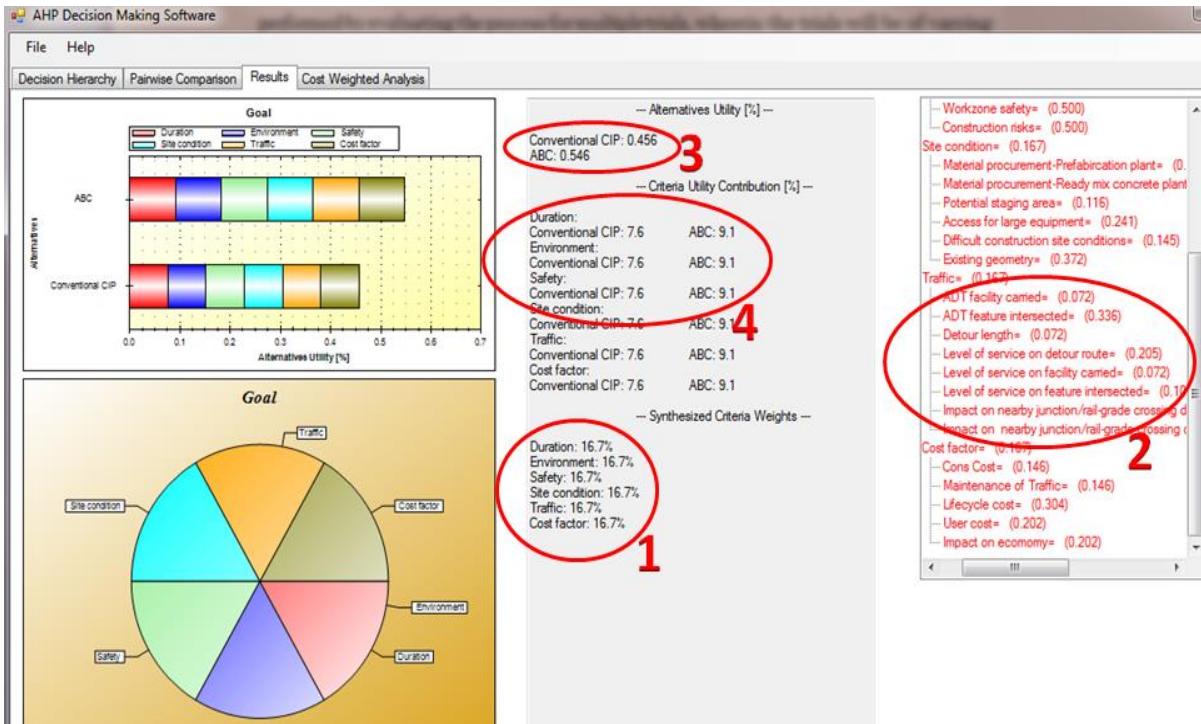

Figure 2-34. AHP decision-making software evaluation result for a prototype site

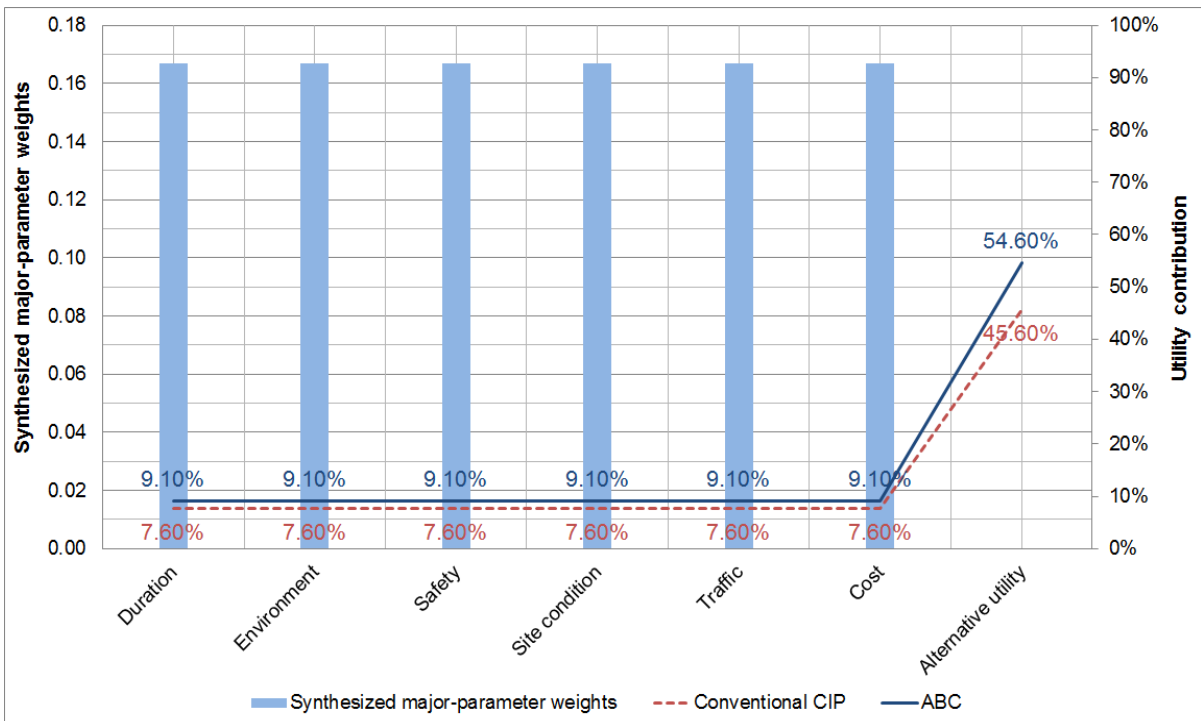

Figure 2-35. Plot of sensitivity analysis results from AHP decision-making software for a prototype site

2.7.12 Summary of Limitations in the Available Decision-Making Models

Several decision-making models reviewed during this study use the common strategy of requiring *Yes* or *No* inputs without any relative significance of critical parameters. Other decision-making processes are not really practical as they require significant amount of survey and research. Also, a few of the decision-making models do not include a consistent method to assign weights and preference ratings for the parameters.

Some of the advanced analysis-based decision-making models (e.g., linear programming, fuzzy AHP, etc.) include increased complexity as intricate mathematical calculations are required. Moreover, in some cases relating objective function and constraints to the qualitative parameters can get very complex.

Project specific data (quantitative data) is required to support the decision in the decision-making process. This would prevent the users to rely upon their subjective decision.

For the models using AHP methodology, the inability to address the consistency ratio while using the approximate method for calculating the local priorities is a major shortcoming. This may lead to erroneous results. Moreover, for higher order matrices, consistency may be difficult to achieve without *a computing aid*, because the number of transitive rules to be satisfied increases in a quadratic order.

The pair-wise comparison matrix is an in-depth process required in AHP. For an ideal AHP calculation, the *final weight* of each alternative at the level of each major-parameter should be calculated by integrating the major-parameter local priorities with their sub-parameter local priorities. The *final weight* should have a different value if any of the major-parameter or sub-parameter preference ratings are different.

Furthermore, the decision-making models developed are for a single user who is expected to know all the facts and data related to the project. Thus, there is a need to develop a collaborative decision-making model and a tool which allows preference ratings from multiple users.

Above all, the decision making models presented so far lack the use of project specific quantitative data. Therefore, there is a need to develop an ABC decision-making model that incorporates project specific data and available user-cost and life-cycle cost models to facilitate users with necessary quantitative data to make informed and accurate decisions. Moreover, some of the decision-making processes imply the need of precision for consistent results. To assure consistency and accuracy the decision-making model can incorporate further automation to improve usability along with addressing the sensitivity of results. The decision-making model could be implemented using available programming platforms such as Microsoft Excel/ Visual Basic/ Mathcad/ Matlab.

Intentionally left blank

3 PERFORMANCE, CHALLENGES, AND LESSONS LEARNED

3.1 OVERVIEW

This chapter presents (a) the causes of premature deterioration, potential measures to enhance durability performance of the earlier ABC implementations, and recommendations for future research and (b) the challenges and lessons learned from review of ABC projects.

3.2 FIELD PERFORMANCE OF BRIDGES CONSTRUCTED USING ABC TECHNIQUES

Performance of (a) full-depth deck panel systems, (b) side-by-side box-beam systems, and (c) bridges constructed using Self Propeller Modular Transporters (SPMT) or the slide-in techniques were reviewed. Appendix C provides description of each bridge, design details (where available), durability performance of full-depth deck panel systems and the bridges constructed using SPMTs or slide-in. This section presents the causes of premature deterioration, potential measures to enhance durability performance of the prefabricated bridge systems, and implementation recommendations.

3.3 CAUSES AND METHODS TO ABATE PREMATURE DETERIORATION OF FULL-DEPTH DECK PANEL SYSTEMS

Cause-1: Leakage through the transverse joints and shear pockets in full-depth deck panel system (Culmo 2010).

Measures	Description (Culmo 2010)
Avoid welded tie plate connections at transverse joints.	The live load at the middle portion of the deck panel will induce transverse as well as longitudinal bending in the deck panel. As the welded tie connection does not have adequate moment capacity, it may lead to failure of the connection. Moreover, a thin polymer overlay will not be sufficient to prevent the leakage in this situation.
Use post-tensioning in conjunction with grouted shear key at transverse connection.	Minor shrinkage of shear key grout during the construction, may develop cracks. Longitudinal post-tensioning after the grouting operation and using an overlay could prevent leakage.
Use superior quality grouting material, effective curing method, and a superior quality overlay.	Gaps and cracks in the grouted joints and grouted shear pockets may allow active leakage. These may be developed due to minor shrinkage of the grout after placement. The minor shrinkage in the grout may be due to quality of grout and/or lack of effective curing. Moreover, frequent exposure of the grouting material with de-icing salts could result in joint degradation and leakage. The use of waterproofing membrane and a superior quality overlay could prevent leakage.

Cause-2: Lack of post-tensioning to secure the tightness of the joints in a full-depth deck panel system (Sullivan 2003).

Measures	Description
Longitudinal post-tensioning	The precast concrete panels should be post-tensioned longitudinally to secure tightness of transverse joints, thus avoiding leakage (Issa <i>et al.</i> 1995b).
Treating joints with caulking material	Caulking material can be used for patching the openings in the joints; thus preventing leaching action through joints and preventing deposits and stains forming (Sullivan 2003).
Grouting joints with magnesium phosphate	Self-leveling Magnesium phosphate grout can be applied at temperatures as low as 15° F. Grout can gain a compressive strength of 5000 psi within 3 hours and flexural strength of 600 psi at 24 hrs along with 600 psi slant shear bond strength (Sullivan 2003).
Proper shear key connection	A shear key should be female-to-female type with at least 0.25 in. opening at bottom to allow any panel irregularities. The joints in which panels are in contact at the bottom should not be used (Issa <i>et al.</i> 1995b; Issa <i>et al.</i> 2007).

Cause-3: Leakage through cracks at the cast-in-place closure pours in full-depth deck panel system (Culmo 2010).

Measures	Description (Culmo 2010)
Use concrete material which has very low shrinkage and is consistent with thermal behavior of the deck panels.	Cracking is likely at the interface of the closure pour with the precast deck panels which are fabricated in a prefabrication plant. This aspect is magnified when high early strength concrete is used in the closure pour; since high early strength concrete tends to shrink more than conventional concrete. Moreover, the thermal behavior of closure pour concrete should be equivalent to the deck panels; since inconsistent thermal behavior of the deck panels with closure pour may lead to cracks, thus leakage. Using waterproofing membrane and a superior quality overlay may alleviate this issue.

Cause-4: Insufficient stiffness of the bridge superstructure results in increased strain values in top and bottom portions of beam, thus affecting the panel-beam connection integrity.

Cause-5: Limited numbers of shear connectors are also a factor that affects the beam-panel connection integrity as the compressive force is likely to exceed the shear strength provided by the shear connectors.

Cause-6: Lack of composite action between deck panels and beams will result in slippage at the interface (Smith-Pardo *et al.* 2003).

Measures	Description
Use of shear studs	Shear studs can be used for connecting precast concrete panels with supporting system through shear connection pockets. But a proper construction procedure of providing haunches and considering dimensional irregularities should be maintained to obtain satisfactory results (Issa <i>et al.</i> 1995b; Issa <i>et al.</i> 2007).
Consider a supporting system made of precast concrete	Use of precast concrete supporting system, which is stiffer than a steel supporting system, helps in reducing problems encountered in bridge decks (Issa <i>et al.</i> 1995b; Issa <i>et al.</i> 2007).

Cause-7: Poor condition of overlay in full-depth deck panel system (Biswas 1986).

Measures	Description (Issa et al. 1995b; Issa et al. 2007; Markowski 2005)
Rehabilitation of overlay with epoxy concrete overlay	The entire deck needs to be cleaned off of all potential detrimental materials. The epoxy requires the first course at a rate of 2.5 gal per 100 ft ² surface area and aggregate application at a minimum of 10 lbs per yd ² and the second course at a rate of 5 gal per 100 ft ² surface area and application of aggregate at 14 lbs per yd ² . Each course of this overlay needs sufficient curing before the next application.
Rehabilitation of overlay with EP-5 concrete overlay	EP-5, which is low modulus patching adhesive, needs the first course of application at a rate of 1 gal per 75 ft ² and the second course at 1 gal per 50 ft ² rate with 11 lbs per yd ² of sand in between the two courses. This epoxy resin needs to be cured sufficiently so that no tearing occurs during brooming action.
Rehabilitation with Latex Modified Concrete (LMC) as overlay	LMC is a standard type of overlay used in many projects across the country. It achieves 3000 to 3500 psi compressive strength within 2 to 3 days. Normal curing requires one day moist cure with air drying during the remaining curing regime. High early strength can be obtained in 24 hrs with use of Type-III cement in LMC. The application cost is \$900 to \$1000 per yd ³ .
Rehabilitation with Silica fume overlay	This overlay is much more opportune and efficacious than conventional latex modified concrete overlay. Silica fume overlay requires only 1.25 in thickness, is less susceptible to temperature changes and costs \$600 per yd ³ , which is 40 cheaper than the LMC material. The surface should be clean of curing compounds or other chemicals and wetted at least 1 hr before overlaying.
Using an overlay with a waterproofing membrane	An overlay, along with a waterproofing membrane, is essential to avoid any penetration of water through the deck joints and for good performance of the bridge deck. Mostly, latex modified concrete was used as overlay, but currently silica fume concrete is in use, due to its low cost and less sensitivity to temperature change.

Cause-8: Deep shear cracks near the edge of the panels in a full-depth deck panel system (Markowski, 2005).

Measures	Description
Treat Crack with High Molecular Weight Methacrylate (HMWM).	HMWM can be used both for crack sealing and treatment of concrete surfaces. This can fill 0.25 to 0.50 inch cracks in depth and can be used for situations of randomly oriented cracks where grouting and sealing are not obvious. Shot-blasting is necessary prior to placing HMWM (Issa <i>et al.</i> 1995b; Issa <i>et al.</i> 2007). Panel capacity can be increased with prestressing.

Cause-9: Punching shear is a likely mechanism causing failure in full-depth deck panel systems that are continuous over girders and subjected to significant amount of traffic (Sullivan 2003).

Measures	Description
Controlling traffic volume	The structural behavior of a bridge is significantly affected by the traffic volume. Hence, the traffic volume should be restricted to design volume to keep the deck in good condition (Issa <i>et al.</i> 1995b). Use of a prestressed deck panel may alleviate this problem.

Cause-10: Stress due to bending while handling is considered a cause for development of cracks in panels (Markowski 2005).

Measures	Description
Transverse prestressing	Precast concrete panels require a sufficient amount of transverse strength during handling to prevent cracks being developed internally during the process, which may develop to be visible over the surface. Thus, prestressing during fabrication of precast concrete panels is required (Issa <i>et al.</i> 2007, Markowski 2005).

Cause-11: Failure of connection at the approach slab and bridge deck interface (Culmo 2010).

Measures	Description (Culmo 2010)
Using cast-in-place closure pours instead of drilled pin or welded tie connections	Cast-in-place closure pours proved to be more durable than the drilled pin connection and welded tie connection. The joint at the approach slab and bridge deck interface should resist the live load impacts, and rotational moment developed due to settlement of sleeper slab. The drilled pin and welded tie connections failed to withstand these effects, causing failure, thus developing pot holes at the approach of the bridge.

3.4 CAUSES AND METHODS TO ABATE PREMATURE DETERIORATION OF BRIDGES MOVED USING SPMT

Cause-12: Diagonal cracks near the ends of the decks that are placed using SPMT (Culmo 2010).

Measures	Description (Culmo 2010)
Using pick-point casting method for field casting	The cracks in the bridge deck are highly dependent on the casting method. When the bridge deck is field cast by supporting at the girder ends and lifted using a SPMT at interior pick-points rather than the girder ends, the stresses developed in the deck will surpass the cracking limits of concrete. The cracks developed may lead to active leaking and affect the long-term performance of the structure. Moreover, a thin polymer overlay will not be sufficient to prevent the moisture ingress in this situation. Therefore, casting the deck by supporting the girders at interior pick-point locations is recommended when a <i>SPMT</i> is used to move the bridge.
Providing adequate time for curing and casting end-diaphragms and parapets once deck is hardened enough to sustain the stresses due to shrinkage	The cast-in-place concrete decks (conventional and the ones moved using SPMT) showed signs of cracking due to shrinkage in the deck. High early strength concrete is used in these bridge decks. The use of high early strength concrete tends to shrink more than conventional concrete and may magnify the cracking issue. This issue could be alleviated by allowing sufficient time for the deck to cure and shrink before casting concrete end-diaphragms and parapets.

3.5 CAUSES AND METHODS TO ABATE PREMATURE SIDE-BY-SIDE BOX-BEAM DETERIORATION

The side-by-side box-beam belongs to the first generation of Accelerated Bridge Construction (ABC) because it eliminates the cast-in-place concrete deck formwork; thus, it accelerates the construction while minimizing the disruption to traffic. Further, the construction can be accelerated using an overlay on the bridges with low volume of traffic instead of using a cast-in-place concrete deck. The bridge configuration has already been implemented in recent projects under the context of ABC; two examples are the Davis Narrows Bridge in Maine and the Mill Street Bridge in New Hampshire (Russel 2009; Stamnas and Whittimore 2005). In recent years, durability, and safety of this bridge type have also become a concern. The concern was due to longitudinal deck surface cracking reflecting from the longitudinal joints between beams. These cracks permit ingress of surface runoff that get trapped within the shear key zones leading to concealed corrosion of reinforcement as well as prestressing strands. The corrosion activity remains concealed until cracking, delamination, or spalling occur.

NCHRP Synthesis 393 (Russell 2009), which documents transverse connection details used by North American highway agencies, was initiated due to the renewed interest of utilizing side-by-side box-beam bridges for accelerated construction. Significant recommendations of synthesis 393 include full-depth grouted shear keys; use of transverse post-tensioning; incorporating a cast-in-place concrete deck and seven-day moist curing of the deck (Russell 2009). Most recommendations are from Michigan practice, except the use of shear key grout with high bond strength and specific grout curing procedures. Unfortunately, with full-depth shear keys, high levels of transverse post-tensioning, and 6 in. thick cast-in-place concrete decks, Michigan still experiences reflective longitudinal deck cracking. Inspection of a bridge under construction showed that the grout-beam interface cracking develops within a couple of days after grouting and well before the bridge is opened to traffic (Aktan et al. 2009). Michigan transverse post-tensioning design is based on an empirical approach and uses a much greater force magnitude compared to similar practices in other states. Further, Ulku et al. (2010) demonstrated the ineffectiveness of post-tensioning applied through discrete diaphragms in controlling stresses developed in the bridge deck under thermal loads.

After conducting a comprehensive review of the MDOT research reports RC-1470 and RC-1527 (Aktan et al. 2005 and Aktan et al. 2009), on reflective deck cracks, the following facts are derived:

1. Longitudinal reflective deck cracking is common to all side-by-side box-beam bridges, irrespective of age.
2. Shear key is intact, but cracks appear along the beam-shear key interface within two to three days upon grouting the joints.
3. Reflective deck cracks appeared within the first 15 days following deck placement.
4. Reflective deck cracks were first documented above the supports (abutments).
5. Reflective cracks initiated from the top of the deck and propagated through the thickness.

3.6 CHALLENGES AND LESSONS LEARNED

Fourteen ABC related activities were reviewed and summarized in Appendix D. After analyzing the challenges and lessons learned from each of the reviewed projects, they were consolidated and categorized into three major topics: project planning and design, precast element fabrication, and construction operations and tolerances.

3.6.1 Project Planning and Design

- Effective communication, collaboration, and coordination between the designer, contractor, and fabricator are key elements to mitigate the risks, identify and revise the methods of construction, and deliver the project on time.
- Pre-event meetings help in examining the steps involved in the construction phase.
- Careful planning of construction operations is essential for the successful completion of an accelerated bridge construction project.
- While ABC projects may initially cost more, the savings in user costs more than compensate for the initial investment. Furthermore, as ABC projects become common place, the costs will become competitive with conventional construction methods.
- Preparing a contingency plan for unforeseen site conditions during construction is useful to ensure on-time project delivery. The plan will need to address specification

- limitations to allow for flexibility in the selection of materials and construction methods that can accelerate the completion of construction and improve workmanship.
- An emergency response plan is useful to have and needs to delineate the decision making authority, communication protocols, and reporting relationship. This plan must include and clearly define an emergency response checklist, contact information, contracting alternatives, information sharing, and decision making hierarchy.
 - To ensure design requirements are met, it is essential to develop protocols for inspection procedures and site visitations.
 - Incentive and disincentive provisions will encourage the contractor to expedite the construction process.
 - Using the design-build delivery approach can add further time reduction for accelerated bridge construction projects.
 - All stakeholders need to be involved during the construction process.
 - Having only one precast contractor for all pre-fabricated elements will provide a more efficient construction process.
 - Involving the heavy lift contractor during design will facilitate the construction process.
 - The existing structure load capacity is an important factor in selecting the construction method, particularly when allowing the placement of equipment on the existing structure.
 - The staging area for Self-Propelled Modular Transporter (SPMT) system, when used, need to be planned properly.
 - Carefully evaluate the capability of the local concrete supplier when specifying special concrete mixes.
 - During design, identify the grout to be used and consider application limitations when developing connection details.
 - Include a pre-approved grout or demand specific information in special provisions to identify the exact type of grout to be used in the project rather than listing “non-shrink grout.”
 - The designer and contractor may work together on developing connection details.

3.6.2 Precast Element Fabrication

- Using prefabricated elements minimizes the construction time and traffic impacts, and improves safety of motorists and workers in the work zone.
- Standardizing the size of the precast components can improve the efficiency of installation in accelerated construction.
- Precast units need to be monitored during fabrication and post-tensioning operations.
- Consider using larger precast elements which will reduce the time and cost of fabrication, delivery, and erection.
- Properly sizing substructure elements allows efficient installation.
- Fabrication of components at the job site, or at a nearby location, will reduce the construction cost and the impact of load restrictions.
- Contractors need to investigate economical alternatives for temporary structures, supports, formwork, and material.
- Late submittal of shop drawings tends to push back the project completion data.

3.6.3 Construction Operations and Tolerances

- The SPMT can be used in bridge construction as well as deconstruction.
- A lift test prior to the scheduled move is needed to avoid operational delays.
- Simple connection details and lighter sections are needed to prevent the difficulties of placing pier caps on columns.
- Grout connection details need to be reviewed with special attention to the grouting operation.
- Since prestress shortening is not well controlled, fitting the alignment pins into the pier caps is a challenge (i.e., pier cap to column connection).
- Simple and durable connection details at the abutments need to be developed.
- The impact of missing shear connectors needs to be evaluated due to the difficulty of drilling girder flanges when there is a misalignment. Designers need to consider providing more flexible connection mechanisms.
- Simple connection details at the foundation and abutment need to be developed minimizing required grouting efforts.

- Consider using epoxy polymer deck overlay when precast elements are used.
- Consider specifying material properties and applicable evaluation methods (i.e., historical data or testing).

Intentionally left blank

4 THE MICHIGAN ACCELERATED BRIDGE CONSTRUCTION DECISION-MAKING (Mi-ABCD)

4.1 OVERVIEW

State-of-the-art decision making models were reviewed, and the shortcomings of the existing models are documented in Chapter 2. To overcome the limitations in the available decision-making processes, a multi-criteria decision-making process and a guided software program were developed. The software, titled Michigan Accelerated Bridge Construction Decision-Making (Mi-ABCD), evaluates the Accelerated Bridge Construction (ABC) vs. Conventional Construction (CC) alternatives for a particular project. The process incorporates project-specific data with user-cost and life-cycle cost models to provide input to the decision makers with quantitative data. The software is developed using Microsoft Excel and Visual Basic for Applications (VBA) scripts. A user manual is developed for the software and is presented in Appendix E. The multi-criteria decision-making process discussed in this chapter provides solutions to all the issues raised by the mid-north regional state DOTs related to ABC decision-making and cost justification which are listed in the *Mid-North Regional Peer-to-Peer Exchange Final Report* (FHWA 2012).

This chapter presents an overview of the software and its application for a specific bridge site. Also, a brief summary is presented comparing the capabilities and advances of Mi-ABCD with the software developed through a pool fund study by the Oregon State University which is commonly used for making ABC decisions.

4.2 THE Mi-ABCD PROCESS

4.2.1 Sample Popup Menus and Datasheet

The VBA's Graphical User Interface (GUI) forms are utilized to interact with the user. These forms are termed as *Pop-up Menus* (Figure 4-1-a and b), and the Excel sheets that are customized for user input are termed as *Datasheets* (Figure 4-1-c). The main features of the *pop-up menu* are to provide (1) Command buttons, (2) Dropdown menus, (3) Tabs, (4) Text fields, (5) Check boxes, and (6) an Additional information button () (Figure 4-1-a and b). The most commonly used features are the *command buttons* and *dropdown menus*. The

primary features of a *datasheet* are (1) Command buttons, (2) Dropdown menus, and (3) Data input fields (Figure 4-1-c).

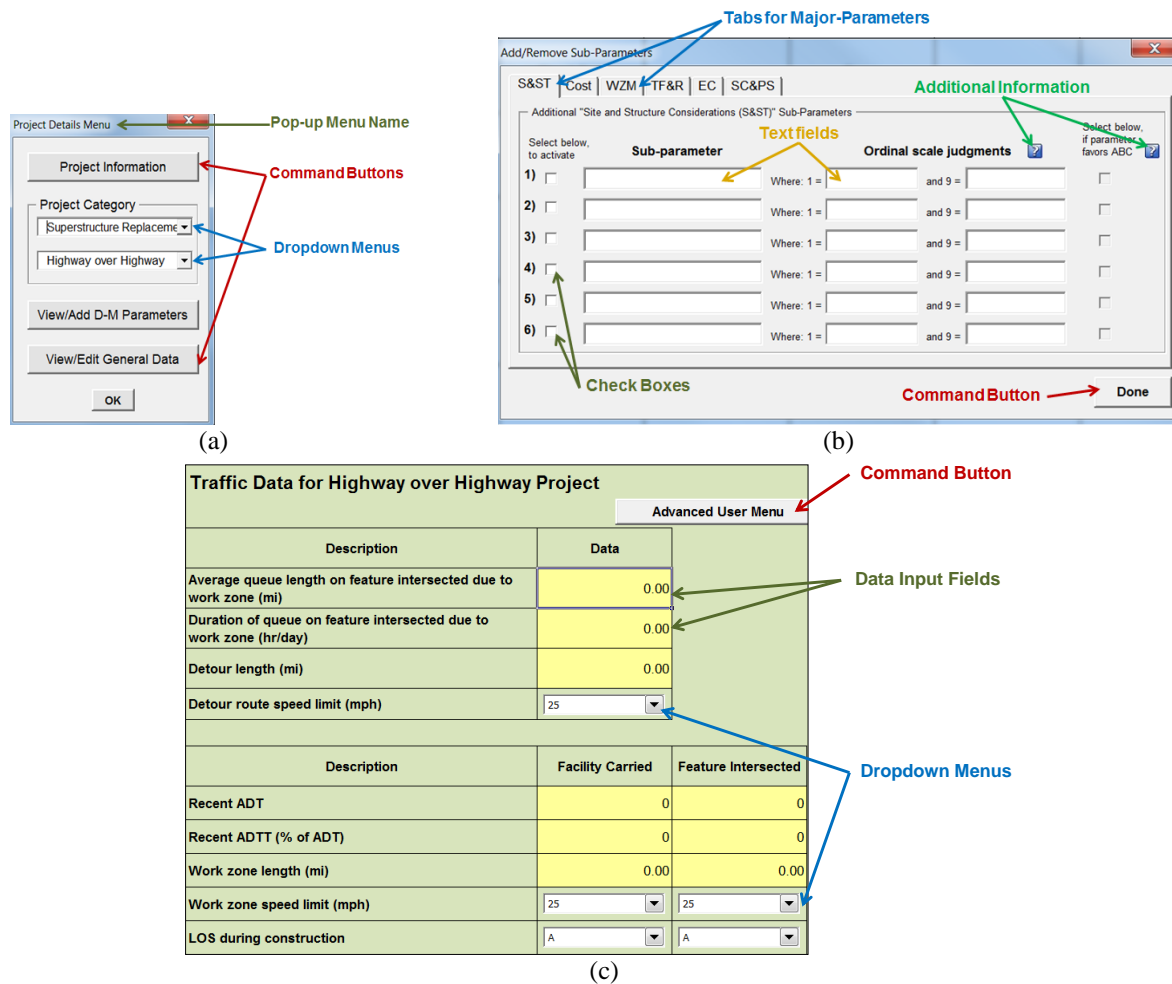

Figure 4-1. Sample popup menus and datasheet

4.2.2 User Menus

The software allows data entry for two user types; *Advanced User* and *Basic User*. The *Advanced User* is generally envisioned to be the project manager who is familiar with the project specifics of site-specific data, cost estimates, traffic data, and construction methodologies. The *Advanced User* enters and/or edits *Project Details*, *Site-Specific Data*, *Traffic Data*, *Life-Cycle Cost Data*, and *Preference Ratings*. Finally, the *Advanced User* can execute data analysis and view *Results*. The *Advanced User Menu* (Figure 4-2a) includes the command buttons for entering and editing data, data analysis, and viewing results. In order to execute the decision-making process, the *Advanced User* must complete all the data entry steps before any *Basic User* can use the program.

The *Basic User* is envisioned to be an expert who will make preferences on qualitative parameters based on their experience on most recent bridge projects. The *Basic User* can view *Project Information*, enter *Preference Ratings*, execute analysis, and view *Results* (Figure 4-2b). One of the advanced features in this software is that it allows the *Basic User* to include their reasoning in the comment boxes while assigning *Preference Ratings*. The subsequent users can view the comments from previous users, but not the ratings.

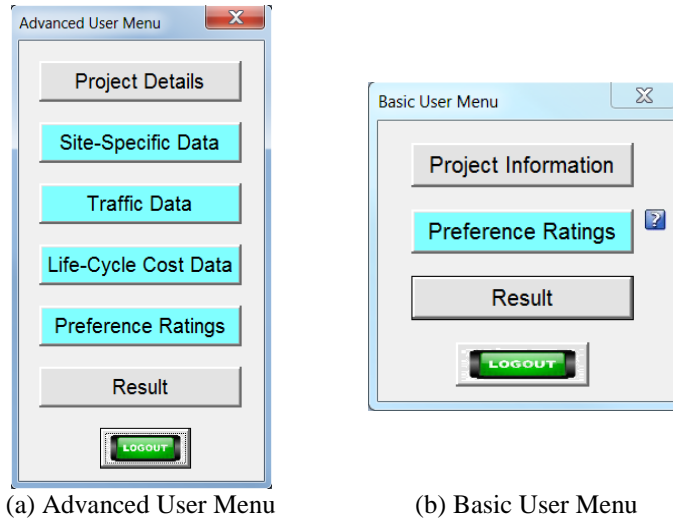

Figure 4-2. User menus

4.2.3 Implementation of Mi-ABCD Process

The bridge project for Mi-ABCD implementation is the Stadium Drive (I-94 BR) over US 131 in Kalamazoo County, Michigan. The data was collected for the Mi-ABCD process assuming bridge construction option will be the use of prefabricated bridge elements and systems (PBES). First, the *Advanced User* needs to complete all the data entry in the *Advanced User Menu* before requesting *Basic User* to provide *Preference Ratings*.

4.2.3.1 Data Entry using the Advanced User Menu

First step by the *Advanced User* (AU) is the entry of *Project Information* (Figure 4-3a). AU selects *Project Category*, *View/Add D-M Parameters* (Figure 4-3b), and *View/Edit General* data using *Project Details Menu*. For this project, the AU choice was not to add additional decision-making (D-M) parameters. The *General Data* (wage rate of drivers, vehicle operating cost, accident cost, and accident rate) is incorporated into the program knowledgebase and

does not require frequent changes. Hence, the AU choice was not to change *General Data* for this project.

Project Details Menu

Project Information

Name:	Stadium Drive
Date:	8/1/2013
By (advanced user):	UBA
Description:	I-94 BR over US-131, Kalamazoo County. This is the major route to the Western Michigan University and to two hospitals, Borgess and Bronson. This is also a major route to Kalamazoo downtown.



(a) Project Information

Decision-Making Parameters for Highway over Highway Project							Project Details Mer
Major-Parameters	Site and Structure Considerations (S&ST)	Cost	Work Zone Mobility (WZM)	Technical Feasibility and Risk (TF&R)	Environmental Considerations (EC)	Seasonal Constraints and Project Schedule (SC&PS)	
Sub-Parameters	Precaster/Ready-mix supplier proximity	Initial Construction cost	Significance of maintenance of traffic on facility carried	Contractor experience	Environmental protection (e.g., wet land)	Seasonal limitations	
	Availability of staging area	Life-cycle cost	Significance of maintenance of traffic on feature intersected	Manufacturer/ Precast plant experience	Aesthetic requirements	Construction duration	
	Existing structure type and foundations	User cost	Length of detour	Work zone traffic risk		Stakeholder(s) limitations	
Sub-Parameters	Terrain to traverse	Economic impact on surrounding businesses	Significance of level of service on detour route	Construction risks			
	Access and mobility of construction equipment	Economic impact on surrounding communities	Impact on nearby major intersection due to traffic on facility carried				
	Number of similar spans		Impact on nearby major intersection due to traffic on feature intersected				
Add Sub-Paramete							

(b) Decision-Making Parameters for Highway over Highway Project

Figure 4-3. (a) Project information and (b) decision-making parameters for highway over highway project

The second step by the AU is to enter *Site-Specific Data* (Figure 4-4a), *Traffic-Data* (Figure 4-4b), and the *Life-Cycle Cost Data* (Figure 4-5) using the command buttons in the *Advanced User Menu* shown in Figure 4-2a.

Site-Specific Data for Highway over Highway Project

[Advanced User Menu](#)

Description	Data
County of the project	Kalamazoo
Distance to ready-mix concrete plant	11-20 miles
Distance to prefabrication plant	≤ 10 miles
Distance to a potential staging area	≤ 10 miles
Number of major intersections for facility carried	2
Number of major intersections for feature intersected	1
Number of similar spans	2

Description	Facility Carried	Feature Intersected
Functional class	Urban freeway (Peak hou	Urban freeway (Peak hou
Traffic directionality	2	2
Number of lanes in each direction	3	3
Speed limit (mph)	45	70

(a)

Traffic Data for Highway over Highway Project

[Advanced User Menu](#)

Description	Data
Average queue length on feature intersected due to work zone (mi)	1.13
Duration of queue on feature intersected due to work zone (hr/day)	4.00
Detour length (mi)	1.24
Detour route speed limit (mph)	45

Description	Facility Carried	Feature Intersected
Recent ADT	41774	52085
Recent ADTT (% of ADT)	3	12
Work zone length (mi)	0.00	1.00
Work zone speed limit (mph)	NONE (Full Closure)	45
LOS during construction	NONE (Full Closure)	C

Description	Before Construction	During Construction using CC	During Construction using ABC
LOS on detour route	B	D	D
LOS on nearby major intersection-1 due to traffic on facility carried	B	D	D
LOS on nearby major intersection-2 due to traffic on facility carried	B	C	C
LOS on nearby major intersection-1 due to traffic on feature intersected	A	B	B
LOS on nearby major intersection-2 due to traffic on feature intersected	N/A	N/A	N/A

(b)

Figure 4-4. Site specific data and traffic data

Life-Cycle Cost Data		Advanced User Menu	
Description	Data		
Number of years for life-cycle cost analysis	75		
Discount factor (%)	3%		
<small>Note: A high discount factor will make the life-cycle cost less important than a low discount factor, and vice-versa. Generally, a discount factor around 3% to 5% is considered reasonable with average close to 4% (FHWA 1998; Thoft-Christensen 2009).</small>			
Description	Conventional Construction (CC)	Accelerated Bridge Construction (ABC)	
Construction duration (days)	152	60	
Initial construction cost (\$)	\$6,000,000	\$7,500,000	
Cost per each maintenance/repair activity (\$)	\$120,000	\$150,000	
Average duration between the maintenance/repair activities (year)	15	35	
Disposal cost or salvage value (\$)	\$600,000	-\$750,000	
<small>Note: At the end of life-cycle cost analysis period, if the structure has either a residual life or a salvage value, the input amount should be negative.</small>			

Figure 4-5. Life-cycle cost data

The third step by the AU is to enter their *Preference Ratings* (Figure 4-6). The user can include their reasoning for the ratings in a text box adjacent to the rating box. Figure 4-6 shows the comments and the *Preference Ratings* entered by the AU as *User-1*. Once the AU data entry is complete and *Preference Ratings* as *User-1*, now the data need to be saved. Following, AU exits, the program with the data is forwarded to experts who will access Mi-ABCD as the *Basic User* (BU) to enter their *Preference Ratings*. The subsequent BU will be able to see the comments provided in the *Preference Rating* datasheet by the previous users. Only the AU is allowed to see the *Preference Ratings* together the comments provided by the users. Once the BU completes entering *Preference Ratings*, they can perform the analysis by clicking the *UserX-OK* button (e.g. *User1-OK* button shown in Figure 4-6). The analysis results are viewed by clicking the *Result* button in the user menu (Figure 4-2). Figure 4-7 shows *Preference Ratings* entered by the third user together with the comments from the two previous users.

Figure 4-8 shows the analysis results in three formats, a pie chart, a bar chart, and a line chart. Pie charts describe the upper and lower bound results between the “users.” As shown in the Figure 4-8, ABC upper bound preference rating is 77% and the lowest bound is 63%. The chart on right shows distribution of major-parameter preferences from respective users. As an example, the User-1 preference is heavily weighted on the cost parameter (i.e., 38%). That is 30% for ABC and 8% for CC. These values are graphically represented in the chart below (the cost values are represented in orange). Further, the results are shown in a tabular format (Figure

4-9). The first two rows under cost parameter shows the contribution of cost from *User-1* preference (i.e., 8% and 30%) to the overall preference for CC and ABC (i.e., 31% and 69%).

Preference Ratings for Decision-Making Parameters

Advanced User Menu View the preference ratings of respective user here:

Parameter		Rating Significance		Ordinal Scale Rating (1 to 9)	Comments Provided by (User-1):
		1	9		
Initial construction cost	Conventional Construction: \$6.00 M Accelerated Bridge Construction: \$7.50 M	More flexible	Highly constrained	8 <input type="button" value="▲"/> <input type="button" value="▼"/>	Cost difference is quite large
User cost	Conventional Construction: \$5.88 M Accelerated Bridge Construction: \$2.32 M	Not significant	Extremely significant	5 <input type="button" value="▲"/> <input type="button" value="▼"/>	ABC really helps reduce user cost
Life-cycle cost	Conventional Construction: \$15.65 M Accelerated Bridge Construction: \$8.61 M	Not significant	Extremely significant	9 <input type="button" value="▲"/> <input type="button" value="▼"/>	ABC also reduces LCC
Economic impact on surrounding businesses		Insignificant impact	Extreme impact	9 <input type="button" value="▲"/> <input type="button" value="▼"/>	University as well as Pfizer, Stryker, and hospital employees use this road
Work zone traffic risk		Not significant	Extremely significant	7 <input type="button" value="▲"/> <input type="button" value="▼"/>	Quite high traffic, the accident risk is high
Construction risks (Involved with the proposed ABC technology)		Not significant	Extremely significant	5 <input type="button" value="▲"/> <input type="button" value="▼"/>	Contractor has some experience
Existing structure type and foundations		Not complex	Extremely complex	5 <input type="button" value="▲"/> <input type="button" value="▼"/>	Narrow shoulder width and near entrance and exit ramps
Terrain to traverse (e.g., Viaduct over rapids, deep water, a valley, or restricted access)		Not difficult	Extremely difficult	5 <input type="button" value="▲"/> <input type="button" value="▼"/>	Narrow shoulder width and near entrance and exit ramps
Access and mobility of construction equipment		Not difficult	Extremely difficult	5 <input type="button" value="▲"/> <input type="button" value="▼"/>	Narrow shoulder width and near entrance and exit ramps
Contractor experience (Required for the proposed ABC technology)		Limited experience	Experienced	6 <input type="button" value="▲"/> <input type="button" value="▼"/>	Contractor has some experience
Manufacturer/Precast plant experience (Required for the proposed ABC technology)		Limited experience	Experienced	3 <input type="button" value="▲"/> <input type="button" value="▼"/>	Limited experience
Seasonal limitations		Not significant	Extremely significant	7 <input type="button" value="▲"/> <input type="button" value="▼"/>	Minimum impact to the University during late summer
Stakeholder(s) limitation		Not significant	Extremely significant	7 <input type="button" value="▲"/> <input type="button" value="▼"/>	University and named businesses will be constrained
Environmental protection		Minimal	Extremely important	3 <input type="button" value="▲"/> <input type="button" value="▼"/>	Not significant
Aesthetic requirements		Not a concern	Required	5 <input type="button" value="▲"/> <input type="button" value="▼"/>	Urban area, aesthetics important

User1-OK User-1

Figure 4-6. Preference ratings and comments provide by User-1

Preference Ratings for Decision-Making Parameters

Parameter		Rating Significance		Ordinal Scale Rating (1 to 9)	Comments Provided by (User-3):	Comments Provided by (User-2):	Comments Provided by (User-1):
		1	9				
Initial construction cost	Conventional Construction: \$6.00 M Accelerated Bridge Construction: \$7.50 M	More flexible	Highly constrained	9		We get federal funding for innovations	Cost difference is quite large
User cost	Conventional Construction: \$5.88 M Accelerated Bridge Construction: \$2.32 M	Not significant	Extremely significant	3		ABC has a significant impact	ABC really helps reduce user cost
Life-cycle cost	Conventional Construction: \$15.65 M Accelerated Bridge Construction: \$8.61 M	Not significant	Extremely significant	7		ABC reduces LCC	ABC also reduces LCC
Economic impact on surrounding businesses		Insignificant impact	Extreme impact	7		Businesses get cutoff during construction	University as well as Pfizer, Stryker, and hospital employees use this road
Work zone traffic risk		Not significant	Extremely significant	5		Compared to similar projects, we can manage it	Quite high traffic, the accident risk is high
Construction risks (Involved with the proposed ABC technology)		Not significant	Extremely significant	3		Contractor has some experience	Contractor has some experience
Existing structure type and foundations		Not complex	Extremely complex	2		Not a significant challenge	Narrow shoulder width and near entrance and exit ramps
Terrain to traverse (e.g., Viaduct over rapids, deep water, a valley, or restricted access)		Not difficult	Extremely difficult	2		Some challenges use to US-131	Narrow shoulder width and near entrance and exit ramps
Access and mobility of construction equipment		Not difficult	Extremely difficult	2		Have access ramps and median	Narrow shoulder width and near entrance and exit ramps
Contractor experience (Required for the proposed ABC technology)		Limited experience	Experienced	5		Not well experienced	Contractor has some experience
Manufacturer/Precast plant experience (Required for the proposed ABC technology)		Limited experience	Experienced	5			Limited experience
Seasonal limitations		Not significant	Extremely significant	5		University and the winter conditions are the biggest challenges	Minimum impact to the University during late summer
Stakeholder(s) limitation		Not significant	Extremely significant	7		University, hospitals, and other businesses	University and named businesses will be constrained
Environmental protection		Minimal	Extremely important	2		Due to close proximity to the businesses	Not significant
Aesthetic requirements		Not a concern	Required	8			Urban area, aesthetics important

Figure 4-7. User-3 provides Preference Ratings while observing previous users' comments

Result for Highway over Highway Project

Edit/View My Ratings & Re-Analyze

Basic User Menu

Upper Bound Rating Result

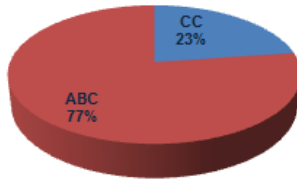

Lower Bound Rating Result

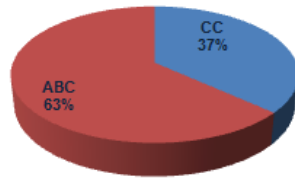

ABC: Accelerated Bridge Construction
CC: Conventional Construction

SC&PS: Seasonal Constraints and Project Schedule
EC: Environmental Considerations
TF&R: Technical Feasibility and Risk
WZM: Work Zone Mobility
Cost: Cost
S&ST: Site and Structure Considerations

Distribution of Major-Parameter Preferences from Multiple Users

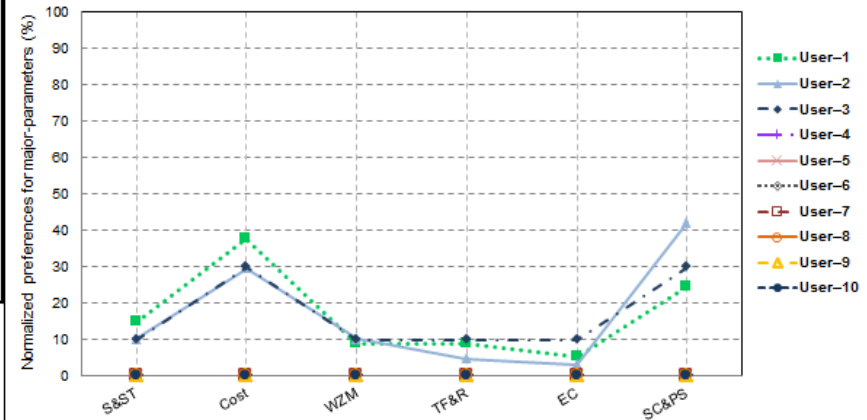

Distribution of Construction Alternative Preferences from Multiple Users

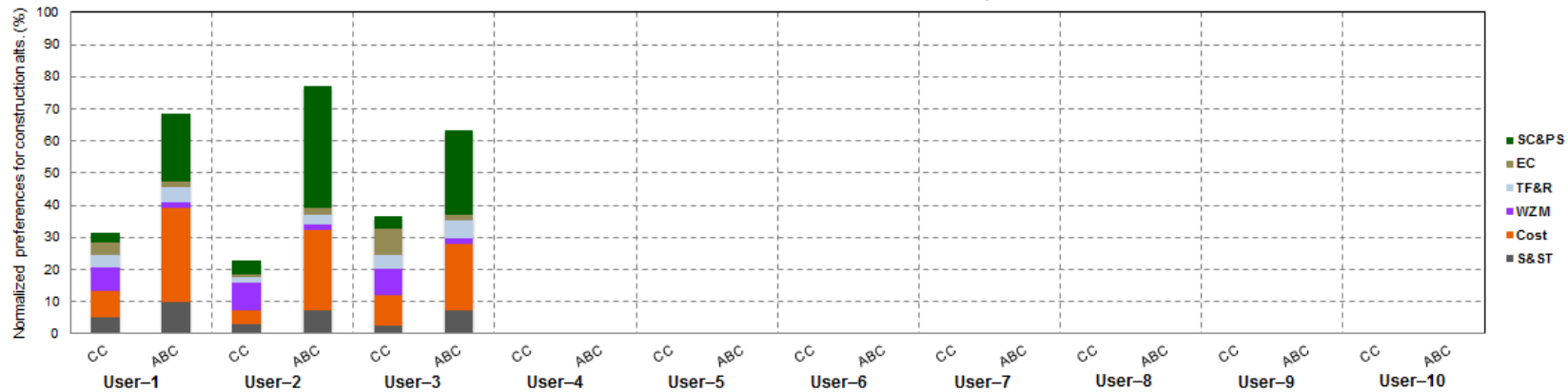

Figure 4-8. Results in chart format

Users or Decision Makers	Construction Alternatives	Site and Structure Considerations (S&ST) (%)	Cost (%)	Work Zone Mobility (WZM) (%)	Technical Feasibility and Risk (TF&R) (%)	Environmental Considerations (EC) (%)	Seasonal Constraints and Project Schedule (SC&PS) (%)	Overall Preference (%)	Edit/View My Ratings & Re-Analyze
User-1	CC	5	8	7	4	4	3	31	Basic User Menu
	ABC	10	30	2	5	2	21	69	
User-2	CC	3	5	8	2	1	4	23	
	ABC	7	25	2	3	2	38	77	
User-3	CC	3	9	8	4	8	4	37	
	ABC	7	21	2	6	2	26	63	
User-4	CC	0	0	0	0	0	0	0	
	ABC	0	0	0	0	0	0	0	
User-5	CC	0	0	0	0	0	0	0	
	ABC	0	0	0	0	0	0	0	
User-6	CC	0	0	0	0	0	0	0	
	ABC	0	0	0	0	0	0	0	
User-7	CC	0	0	0	0	0	0	0	
	ABC	0	0	0	0	0	0	0	
User-8	CC	0	0	0	0	0	0	0	
	ABC	0	0	0	0	0	0	0	
User-9	CC	0	0	0	0	0	0	0	
	ABC	0	0	0	0	0	0	0	
User-10	CC	0	0	0	0	0	0	0	
	ABC	0	0	0	0	0	0	0	

Figure 4-9. Results in tabular format

4.3 MI-ABCD CAPABILITIES AND ADVANCEMENT

Doolen (2011) developed a *Planning Phase Decision Tool for ABC* under a pool fund study with the support from the Federal Highway Administration (FHWA). Even though the tool is developed using the Analytical Hierarchy Process (AHP), the decision makers have to assign preference ratings by making pair-wise comparisons of all decision parameters (Figure 4-10). Further, the users cannot provide comments regarding their preferences. Additionally, supportive data is not provided to help guide the user preferences. Hence, the decisions are not properly articulated, and the aggregate preferences by the users may not yield a coherent decision.

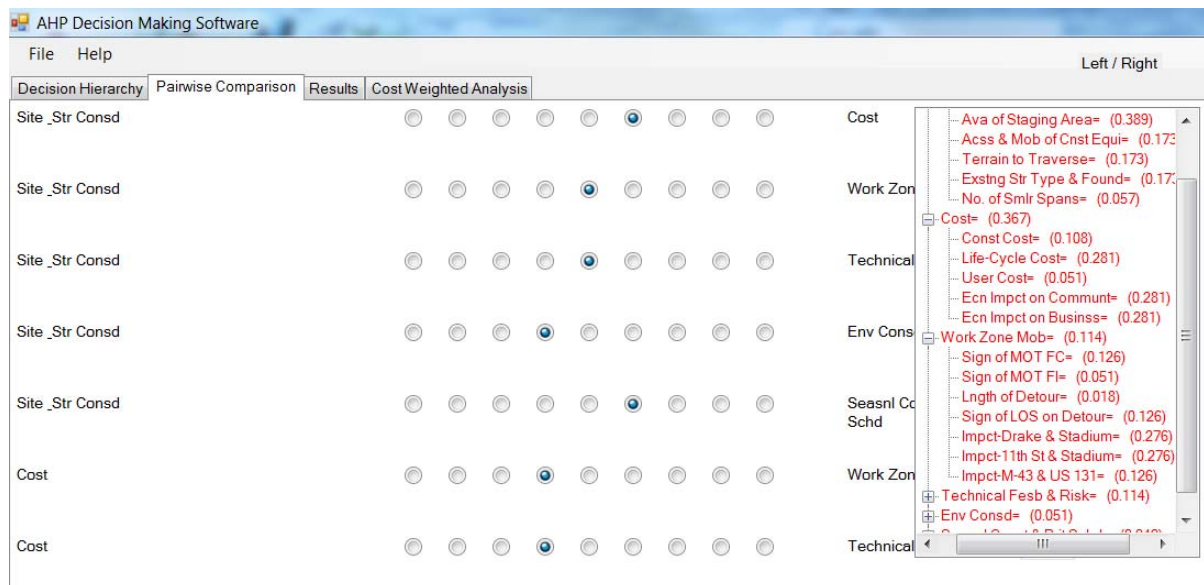

Figure 4-10. Interface of the decision tool developed by Doolen (2011)

The Mi-ABCD is a significant advancement over the FHWA tool. The advanced features of the Mi-ABCD can be summarized as follows:

1. The Mi-ABCD incorporates *Project Information*, *General Data*, *Site-Specific Data*, *Traffic-Data*, and the *Life-Cycle Cost Data* (Figure 4-2a) that guide the user in making informed preferences.
2. Mi-ABCD only requires the users to provide preferences for a set of parameters based on their experience from the previous recent projects. This process helps leveraging the experience gained from past projects to enhance the decision-making process.

3. Users may provide comments while assigning preference ratings. These comments are available to subsequent users. This feature provides an opportunity to develop a user knowledgebase within the process.
4. Mi-ABCD analysis procedure is based on eigenvalue method to calculate overall preference ratings for construction alternatives which assures the consistency of results between multiple users.
5. The comparison shown in Table 4-1 demonstrates that Mi-ABCD process requires less effort from the users.

Table 4-1. Comparison of FHWA/OSU Decision Tool and Mi-ABCD Features

FHWA/OSU Model	Mi-ABCD
Process is based entirely on the expert opinion	Process is based on site-specific data as well as expert opinion
Experts' opinion is represented by pair-wise comparisons of parameters	Experts' opinion is represented by preference ratings using an ordinal scale
Number of pair-wise comparisons for 5 major-parameters require 15 entries	Number of pair-wise comparisons for 6 major-parameters require no entries
Number of pair-wise comparisons for sub-parameters require 56 entries	Number of pair-wise comparisons for sub-parameters require no entries
Number of pair-wise comparisons for construction alternatives require 27 entries	Number of pair-wise comparisons for construction alternatives require no entries
The entire process requires 98 entries	The entire process requires 44 entries
Approximate method (i.e., normalized row average method) is used to calculate the preference ratings	Eigenvalue method is used to calculate the preference ratings

4.4 SUMMARY

The process of making ABC decisions need to be supported by a mathematical process that utilizes tangible bridge construction parameters, site-specific qualitative and quantitative data, and the heuristic experience of the project engineers. The Michigan Accelerated Bridge Construction Decision-Making (Mi-ABCD) process and the associated software platform were developed to address this expectation. The specific conclusions related to the Mi-ABCD are;

1. The Mi-ABCD process is limited to unremarkable bridges only. The process needs to be extended to incorporate bridge with other features such as high skew, long span, etc.

2. At this time the platform is capable of comparing ABC to conventional construction. The platform can be extended also to analyze comparison of various ABC methodologies to a specific site. The goal is to expand the program so that various ABC methodologies together with conventional construction can be compared.
3. Strength of the methodology is the integration of quantitative data to help the user to make qualitative decisions. An additional strength is eliminating pair-wise comparison of parameters and using preference ratings. This is based on the user feedback on the complexities of making pair-wise comparisons between unrelated parameters.

Intentionally left blank

5 CONSTRUCTION AND DECONSTRUCTION PROCEDURES AND DETAILS FOR SELECTED BRIDGE STRUCTURAL SYSTEMS

A thorough literature review presented in Chapter 2, documents (a) prefabricated bridge elements and systems (PBES) currently being implemented and under development, (b) details designed for connecting prefabricated elements and developing continuity details over piers and abutments, and (c) construction and deconstruction procedures. A summary of findings is given in Chapter 2 while a detailed discussion on PBES and connection and continuity details is given in Appendix A and B. This chapter includes (1) recommended PBES including configurations for developing reduced-weight bent/pier caps, (2) connection details for PBES including standard deck-level longitudinal connection details, (3) continuity details over piers and abutments, and (4) construction and deconstruction procedures for selected bridge systems.

5.1 PBES RECOMMENDATIONS

The Prefabricated Bridge Elements and Systems (PBES) recommendations are identified after a critical review of the connection and continuity details described in Appendix A. The review was based on the durability and constructability of the connections. In order to help in identifying a particular prefabricated bridge element, system or combination thereof for a project, the benefits and drawbacks of each element or system are described. Also, in specifying a PBES for a project, it would be useful to review the potential challenges during construction and identify effective means to mitigate such challenges. To help with that effort, constructability challenges and other limitations of the PBES are listed. Further, topology, commonly used span ranges, and material properties associated with each element or system are presented where such information is available. Having such information is useful for identifying elements, systems or a combination thereof suitable for a particular project following the evaluation of site constraints. The source of information for each element or system is also included.

5.1.1 Prestressed Concrete (PC) Girders

The following two girder types are recommended:

1. Precast concrete (PC) I-girders: These girders are recommended, because their formwork is widely available at the precast plants. The depth of AASHTO PC I-girders ranges from 28 in. to 54 in., and their span ranges up to 114 ft. In addition to AASHTO standard sections, the state-specific PC I-girder sections are available to accommodate longer spans. As an example, the Michigan 1800 girder could span up to 145 ft. Moreover, the designers, fabricators, and contractors are familiar with these girders, and past performance data is available that could be utilized in various assessment procedures.
2. Precast bulb-tee girders: These girders are recommended because there is a significant amount of research data available primarily performed by FHWA and various state DOTs. The sections are structurally efficient and cost effective. For example, after evaluating available precast bulb-tee girders in the U.S., the Utah DOT produced standardized girders with a depth ranging from 42 in. to 98 in. and spans ranging up to 186 ft. These girders can also be spliced with the use of post-tensioning to extend up to a span of 220 ft. The formwork of these girders can also be utilized for the decked bulb-tee girder. The decked bulb-tee girder is a potential modular superstructure element, which will be discussed in Section 5.1.3.1 - Modular Superstructure Elements.

For each of the two girder types, a description, a list of citations, and a review of constructability are presented.

5.1.1.1 Precast Concrete (PC) I-Girder

Description: The AASHTO types I to IV girders were developed and standardized in the late 1950s, and AASHTO types V and VI girders were developed in 1960s. As a result of AASHTO standardization, precast plants invested in the formwork for PC I-girders. Thus, the design practices were simplified, and significant cost savings were observed in the construction of prestressed concrete bridges.

The performance of the PC I-girders is well documented. The performance data can be utilized in various assessment/evaluation procedures, such as the life-cycle cost calculation. These

girders were also successfully implemented in Accelerated Bridge Replacement (ABR) projects where Self Propelled Modular Transporters (SPMTs) are used.

Sources of information: Chung et al. (2008); Abudayyeh (2010b); MDOT-BDM (2013); Attanayake et al. (2012); (Ralls 2008).

Constructability evaluation: The PC I-girders are often used to build bridge superstructures that are moved into position using SPMT or the slide-in technique. The only difficulty in using PC I-girders in ABR is to design the girders and deck to accommodate the stresses developed during the bridge move. The implementation of PC I-girders in ABC requires partial-depth or full-depth deck panels. Partial-depth deck panels are not recommended because of reflective deck cracking potential. When used with full-depth deck panels, the girder sweep needs to be controlled. Moreover, cast-in-place (CIP) construction and special details are required to develop continuity over the piers. The continuity details are discussed in Section 5.2.1.4 – Continuity Detail over the Pier or a Bent. Where needed, the curved spans can be constructed using straight PC I-girders.

The PC I-girders are appropriate for short-to-medium span bridges. Girders are prone to end cracking. Girder end cracking potential is high along the transfer length when 0.7 in. diameter prestressing strands are used (Vadivelu 2009). To prevent end cracks, some of the prestressing strands can be debonded near the girder ends to increase the transfer length. The prestressing strands of 0.5 in. and 0.6 in. diameter, and a 28-day concrete strength ranging from 5000 psi to 7000 psi are commonly specified in these girders.

5.1.1.2 Precast Bulb-Tee Girder

Description: In 1980, FHWA initiated a research project to develop an optimized, efficient and economic prestressed concrete girder. The research evaluated the AASHTO standard PC I-girders as well as state specific standard girders. The bulb-tee along with the Washington and Colorado girders were identified as the structurally efficient sections. The bulb-tee girder with a 6 in. web was proposed as a national girder for short-to-medium spans. Later, the PCI committee modified the bulb-tee section (Figure 5-1) and in 1988, they standardized it as the AASHTO/PCI bulb-tee girder (TFHRC 2006). Russell et al. (1997) conducted a comprehensive study on the effect of strand size and spacing on capacity and cost for high-

strength concrete bulb-tee girders. The results indicated that 0.7 in. diameter strands at 2 in. spacing in a precast bulb-tee girder with 10,000 psi strength would provide an economical design for longer spans.

Following evaluation of precast bulb-tee girder sections in the U.S, a series was standardized by the Utah DOT to be formally known as Utah Bulb-Tee (UBT) girders. The depth, span range, and corresponding concrete strength of the standard UBT girders are presented in Table 5-1. The standard drawings for the UBT girders (UDOT 2010b) are presented in Appendix G.

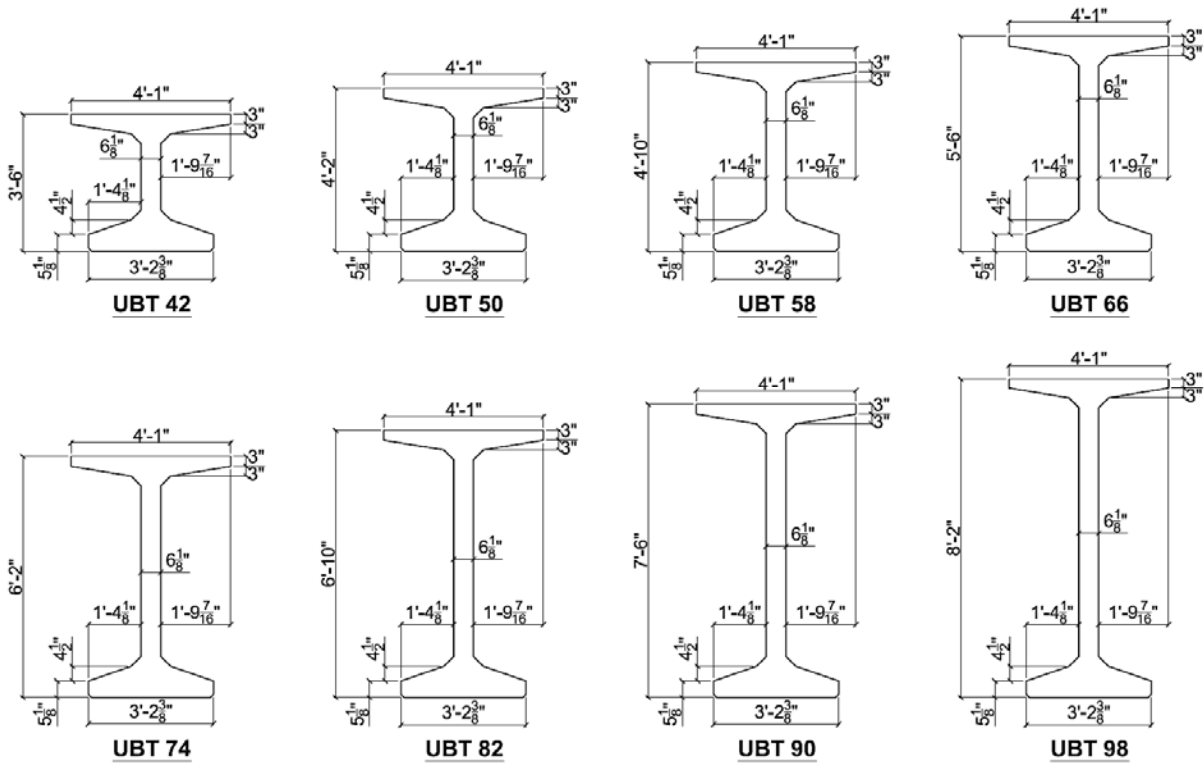

Figure 5-1. Precast bulb-tee girders (Source: UDOT 2010b)

Table 5-1. Depth and Span Range of Utah Bulb-Tee Girders (Source: UDOT 2010b)

	Depth (in.)	Span (ft)		Diameter of prestressing strands (in.)	Number of strands
		28-day concrete strength of 6,500 psi	28-day concrete strength of 8,500 psi		
Utah bulb- tee girders spaced at 8 ft	42	~85	~98	0.6	Varies
	50	~97	~117		
	58	~112	~131		
	66	~124	~146		
	74	~140	~157		
	82	~150	~167		
	90	~164	~177		
	98	~169	~186		

Sources of information: Mills et al. (1991); Seguirant (1998); Lavallee and Cadman (2001); Castrodale and White (2004); Fouad et al. (2006); Browder (2007); UDOT (2010b).

Constructability evaluation: The precast bulb-tee girders are appropriate for developing continuous spans. Special details and CIP construction are required to develop continuity over the piers. (See Section 5.2.1.4 – Continuity Detail over the Pier or a Bent for Details.)

ABC implementation can be accomplished with partial-depth or full-depth deck panels. As indicated earlier, the use of partial-depth deck panels is not recommended due to reflective deck cracking potential. When used with full-depth deck panels, the controlling girder sweep is critical due to slenderness of the section. The use of a wide bottom flange in the precast bulb-tee girders results in a stable section and accommodates a larger number of prestressing strands.

For bridges with restrictions for pier placement, spliced spans extending up to medium spans could be achieved with multiple precast bulb-tee girders. Post-tensioning can be used for the full length of the bridge when spliced spans are utilized. However, the web width needs to be increased in spliced girders to accommodate the post-tensioning ducts (Figure 5-2). Splicing options and details are discussed in the NCHRP report 517 (Castrodale and White 2004).

The splicing operation requires more time that will extend the construction schedule. Further, a CIP concrete diaphragm is typically required at the spliced location. As was mentioned earlier, with post-tensioning, the repair or rehabilitation activity options will be limited. Before

repair, rehabilitation or deconstruction operations, the stability of the system needs to be evaluated.

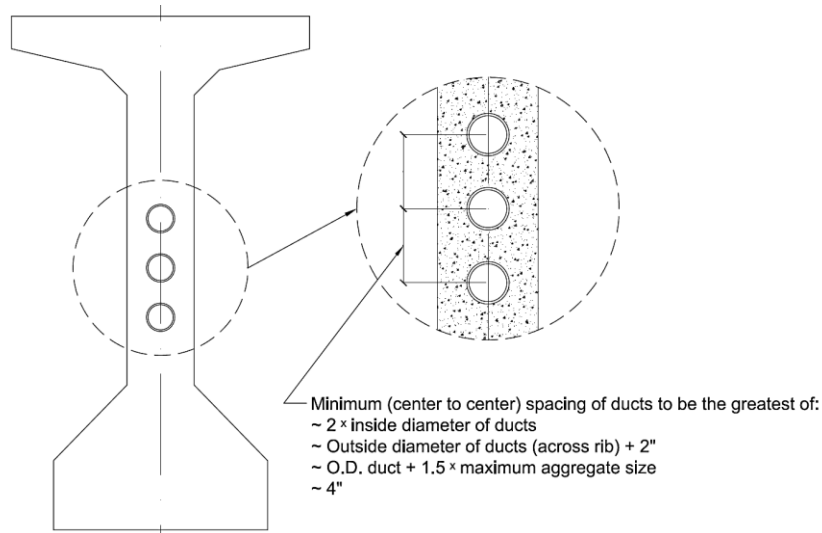

Figure 5-2. Precast bulb-tee with post-tensioning in the web (Source: Castrodale and White 2004)

5.1.2 Full-Depth Deck Panels

DOTs are sometimes reluctant to use post-tensioning (FHWA 2012). However, a full-depth deck panel system with transverse prestressing and longitudinal post-tensioning is recommended. This recommendation is supported by the deck's superior durability performance. Transverse prestressing provides crack control and allows using thinner deck panels and wider spacing of supporting girders. Longitudinal post-tensioning can be designed so that the deck remains under compression under all service load conditions, resulting in a durable system. Moreover, full-depth deck panels have been implemented in several ABC projects, from which lessons-learned reports are available. Additionally, designers and precast plants have experience with the system.

5.1.2.1 Full-Depth Deck Panels with Transverse Prestressing and Longitudinal Post-tensioning

Description: Full-depth deck panels have been used since the early 1970's (Issa et al. 1995a). The full-depth deck panels can be used in the deck replacement, superstructure replacement and bridge replacement projects. The transverse prestressing allows casting deck panels as wide as 40 ft [i.e., dimension in transverse direction of the bridge (Figure 5-3 a)].

The UDOT (2010b) developed standard details for the full-depth deck panels. (See Appendix F for details.) The UDOT (2010b) allows the use of skewed panels up to 15° (Figure 5-3 b). For skew decks up to 45°, rectangular interior panels with trapezoidal end panels are specified (Figure 5-3 c).

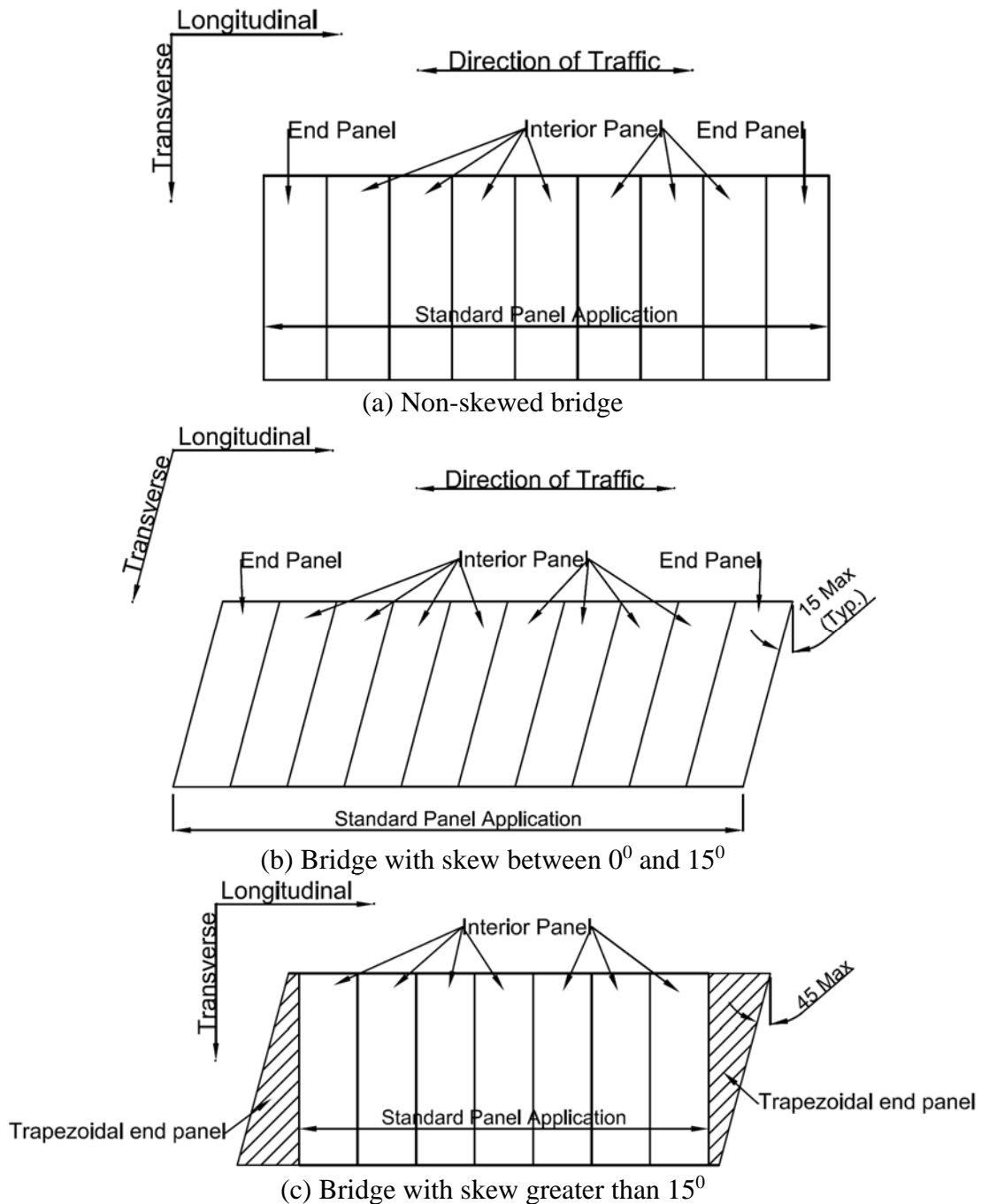

Figure 5-3. Standard full-depth deck panel applications (Source: UDOT 2010b)

Full-depth deck panel length (in the direction of traffic) with transverse prestressing could vary from 8 ft to 16 ft. The panel width (in the direction transverse to traffic) could vary from 24 ft to 40 ft. Several projects specified a deck thickness of 8.5 in. with concrete strength of 4,000 psi at release and 5,000 psi at 28 days. The supporting girder spacing for the deck panels with transverse prestressing could vary from 8 ft to 12 ft. Steel girders with a minimum top flange width of 16 in., AASHTO types II to VI girders, or precast bulb-tee girders are commonly used.

Sources of information: Hieber et al. (2005); Badie et al. (2006); Higgins (2010); UDOT (2010b); Attanayake et al. (2012).

Constructability evaluation: The uncertainty related to the full-depth deck panel's durability performance is the tightness of transverse connections. The connection details promising best performance are discussed in Section 5.2.1.1 – Transverse Connection at the Deck Level.

Staged construction with full-depth deck panels is possible (Figure 5-4). During staged construction, vibrations generated by the traffic may promote cracking within the cement matrix and at the interface of the longitudinal closure. Reinforcement overlapping conflicts at the closure are documented in post-construction reports. This can be addressed by educating the detailers of the issue, while specifying and enforcing the best practices for tolerances.

AASHTO (2010) specifies 250 psi compression at the panel transverse connection after all the prestressing losses. The continuous span structures should be analyzed in the vicinity of the piers to determine the level of post-tensioning required to achieve nominal 250 psi compression at connections. Transverse connections should be placed away from the pier locations to minimize the potential for developing tensile stresses. The maximum post-tension duct spacing should be less than panel length (Ulku et al. 2011). Tolerances at the post-tension duct splicing locations should be appropriate to minimize misalignment. To reduce the difficulties associated with the strand placement in the post-tensioning ducts, round ducts are preferred over the flat ducts (Badie et al. 2006). Moreover, to prevent excessive friction during post-tensioning operation, adequate space should be maintained between the strands and the ducts. For example, if 4-0.6 in. diameter strands are allowed for a particular duct, the design may be based on 4-0.5 in. diameter strands.

The deck system contains several grouted connections thus making the construction challenging. Therefore, special provisions need to direct the contractor to identify the grouting procedures and to demonstrate the effectiveness of the procedures by performing mock-up testing. The difficulties with grout selection and application are discussed in Section 2.4. The panels should be properly supported until the haunch grout achieves the required strength. For supporting the deck panels, in each deck panel, at least two (2) leveling devices per girder need to be provided. Proper tolerances at the shear pockets should be specified and verified. The shear pockets and leveling device details are discussed in Section 5.2.1.3 – Deck-to-Girder Connection–Blockouts.

The following challenges are encountered when implementing full-depth deck panel systems:

- Specifying and enforcing the required tolerances during the fabrication process,
- Enforcing the construction tolerances during the assembly process,
- Transporting the trapezoidal end panels used in the high skew bridges, and
- Replacing a single girder or a panel in a system with post-tensioning.

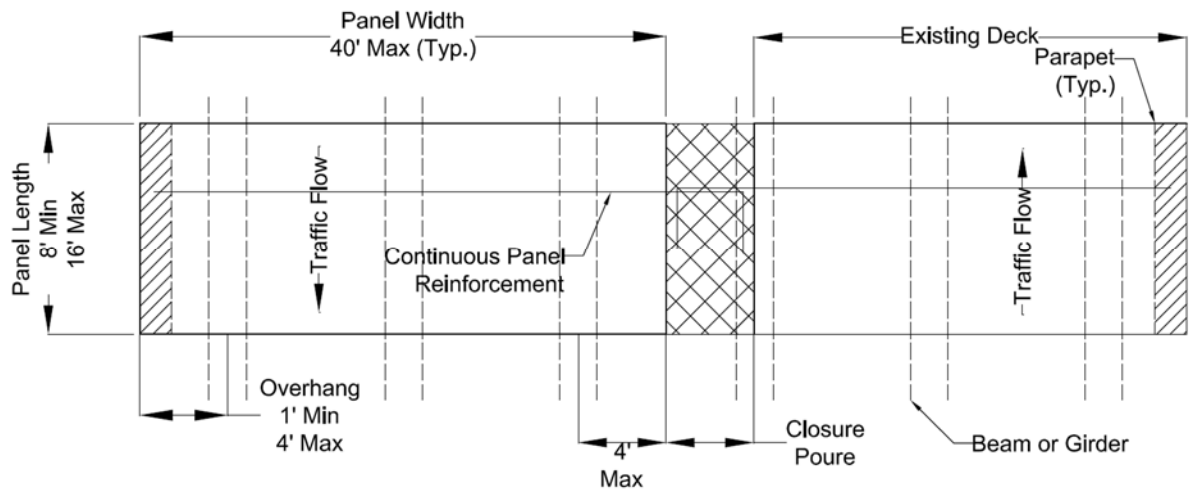

Figure 5-4. Stage construction configuration for full-depth deck panels (Source: UDOT 2010b)

5.1.3 Modular Superstructure Elements

The two modular superstructure elements recommended for potential implementation are described below.

1. Decked bulb-tee girder: This section has been implemented in several projects in Florida, New York, Utah, and a few states in the New England region. UDOT (2010b) standardized this section for spans up to 180 ft. The superstructure can be formed by placing the units next to each other and providing a connection for moment and shear transfer. The superstructure can be designed with or without an overlay. Overlay is recommended for durability. The precast forms for the precast bulb-tee girders could also be utilized to cast the decked bulb-tee girder elements.
2. Decked box-beam: This section is recommended based on recent positive experiences in Michigan. The superstructure can be used with or without an overlay. Again, overlay is recommended for durability. The precast forms for casting the adjacent box-beams could be utilized to cast the decked box-beam elements. Precast plants and contractors often have experience with the precast box-beams; thus, prefabrication of the decked configuration will not be challenging.

5.1.3.1 Decked Bulb-Tee Girder

Description: The decked bulb-tee girder (Figure 5-5) was developed in 1969 by Arthur Anderson based on the standard tee girder. The standard tee girder was commonly specified for parking structures and the building industry in early 19th century. The New England states, Utah, and Florida have specified the decked bulb-tee girder section in several projects. The New York State DOT has implemented this section in a few projects since 2009.

The decked bulb-tee girders can be manufactured in a single pour, which makes the fabrication easier compared to a single cell box-beam. The decked bulb-tee girders provide the flexibility for accommodating utility lines. When compared to the double-tee girder elements, decked bulb-tee girders can be designed for a greater load carrying capacity for equal span lengths. A wearing surface, or an overlay, is required once the decked bulb-tee girders are assembled on the site (Figure 5-6).

UDOT (2010b) standardized the decked bulb-tee girder with flange widths ranging from 4 ft to 8 ft, depths ranging from 35 in. to 98 in., and spans of up to 180 ft. The maximum span has not been implemented in ABC projects primarily due to limitations in transporting the sections to the bridge site. The standard drawings for the decked bulb-tee girder by UDOT (2010b) are presented in Appendix G.

Sources of information: PCI (2011); Shah et al. (2006); UDOT (2010b); Culmo (2011).

Constructability evaluation: As with any modular system, the connections between the decked bulb-tee girders can fail unless designed as a flexure-shear transfer connection. Standard details for deck level longitudinal connection are developed and presented in Section 5.2.1.2 – Longitudinal Connection at the Deck Level.

UDOT (2010b) specifies a span up to 180 ft. As with any other bridge system, use of deep girders for medium span bridges is not practical in most sites due to underclearance issues.

Some considerations related to the use of decked bulb-tee girders are as follows:

- The spacing of the diaphragms between the decked bulb-tee girders needs to be researched to achieve the desired level of torsional stiffness.
- The weight of the decked bulb-tee girders needs to be considered during the design process, to comply with transportation limitations, and
- The crown of the riding surface on the decked bulb-tee girders can be formed by an overlay. There is preference for use of latex modified concrete or epoxy overlay over an asphalt overlay with a waterproofing membrane.

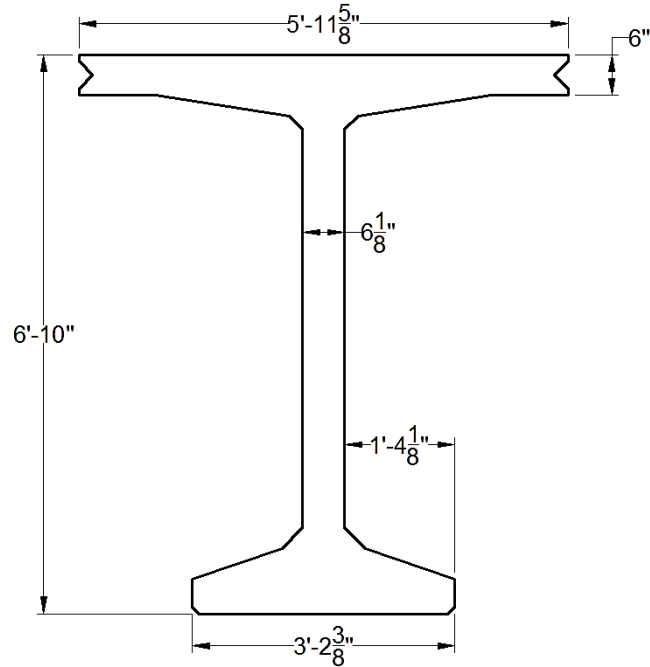

Figure 5-5. Typical section of a decked bulb-tee girder (Source: PCI 2011)



Figure 5-6. Decked bulb-tee girder (Source: CPMP 2011)

5.1.3.2 Decked Box-beam

Description: The decked box-beam element is the traditional box-beam with a built-in deck (Figure 5-7). This element was developed by Michigan DOT to provide a prefabricated element, which inherits the benefits of an adjacent box-beam, and when assembled on site, resembles a spread box-beam bridge. The decked box-beam system was implemented for ABC in 2011 to replace M-25 over the White River Bridge (B01 of 32091) in Michigan. Transverse

post-tensioning similar to side-by-side box-beam bridges, through the CIP diaphragms, was specified. The beam depth was 3 ft (including the deck) and spanned 47 ft. The top flange width of the beams was 5 ft-5 in. The specified 28-day compressive strength was 7000 psi.

The decked box-beam section is suitable at sites with underclearance limitations. As the decked box-beam resembles the spread box-beam bridge, utilities could be accommodated. The weight of the decked box-beam may be the factor limiting the use for short-span bridges (20 ft to 60 ft).

Source of information: MDOT M-25 over White River Bridge plans (2010); MDOT-BDM (2011).

Constructability evaluation: The decked box-beam section is new, and past performance data is limited. The longitudinal deck connection detail used with these beams needs to be designed to transfer both moment and shear. Standard deck level longitudinal connection details are developed and presented in Section 5.2.1.2 – Longitudinal Connection at the Deck Level. The designers should be aware of shipping and handling weight limitations while designing these sections for increased spans.

The typical sequence of precasting the decked box-beam is to fabricate the box-beam, place the deck reinforcement on top of the box-beam, and cast the deck. The deck reinforcement placement and the deck casting operation scheduling is critical to prevent a cold joint between the deck and the box-beam.

Some of the considerations related to the use of decked box-beams are these:

- Difficulty of inspection of the box-beam interior,
- Difficulty in the fabrication, because of the multi-step process, and
- Difficulty in replacing single or multiple units because of the transverse post-tensioning.

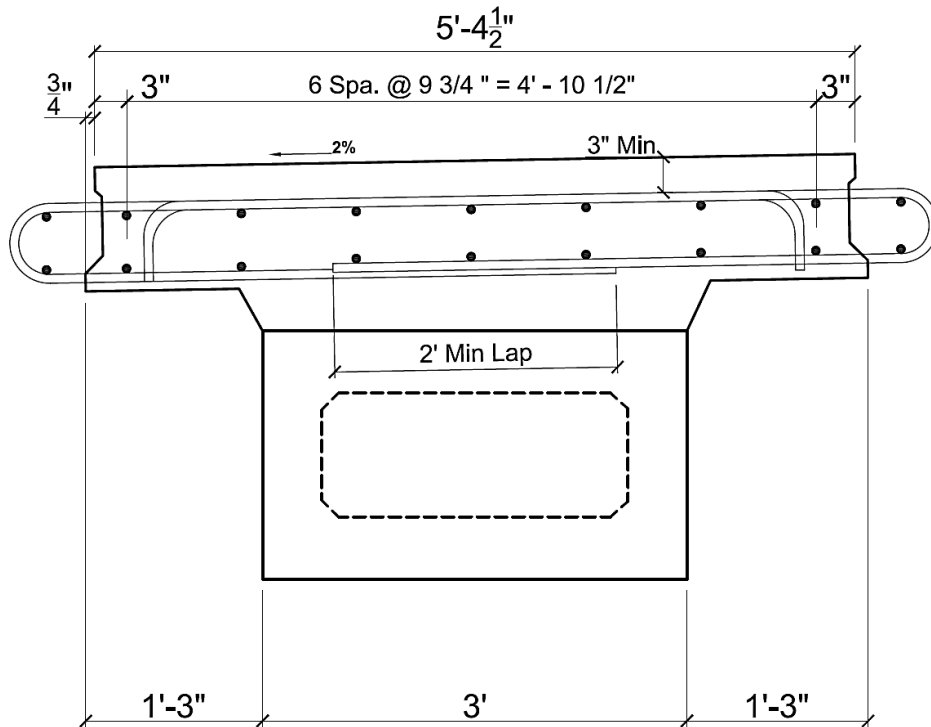

Figure 5-7. Decked box-beam section (Source: MDOT M-25 over White River Bridge plans 2010)

5.1.4 Modular Superstructure Elements with an Implementation Potential

Modular superstructure elements, which have a potential for implementation, but require additional investigation for successful use in ABC projects are presented below:

1. Precast adjacent box-beams: This is the classic system specified to accelerate the construction with several inherent advantages. Many state DOTs, prefabricators, and contractors are familiar with the system. Because of large inventory, the past performance data is available going back to the 1950s. The major obstacle is the reflective deck cracking which leads to premature deterioration. Even with the reflective deck cracking potential, the system is widely specified because of a lack of alternatives for sites with underclearance limitations.
2. Inverted-T precast slab: This element is recommended because of its high span-to-depth ratio, which is suitable for implementation with underclearance limitations. Further, this element eliminates the formwork requirement for the CIP deck. Again, there is potential for reflective cracking along the longitudinal connection. A recent NCHRP-10-71 project proposed a few design changes for improving the connection. The new details have not been tested for performance to determine its durability.
3. Northeast Extreme Tee (NEXT) D beam element: This element is selected because of its higher load carrying capacity than standard double tee girders. These elements are suitable for bridges with up to a 90 ft span and with underclearance limitations. Additional studies are needed on the section in order to clarify the following: i) ambiguous live load distribution, ii) sufficiency of the longitudinal connection detail, and iii) optimality of the cross-section.

5.1.4.1 Precast Adjacent Box-beams

Description: These elements have been in use in Michigan since 1955 (Attanayake 2006). There is extensive experience with their design and performance. These elements are ideal for sites with underclearance limitations. The construction can be accelerated by specifying a wearing surface without a cast-in-place deck directly over the box girders (Figure 5-8). These elements possess high torsional stiffness and can be used for constructing aesthetically pleasing shallow-depth structures.

Sources of information: Aktan et al. (2009); Attanayake (2006); Stamnas and Whittemore (2005); Chung et al. (2008); MDOT-BDM (2011); Ulku et al. (2010).

Constructability evaluation: Field inspection has documented grout spall and inadequate gaps between beams for forming the shear keys (Aktan et al. 2009). Tighter fabrication tolerances need to be specified. Reflective cracking is common among the inventory constructed with a CIP deck. Therefore, a redesign of the transverse connectivity of the adjacent box-beams will mitigate the reflective cracking (Ulku et al. 2010). Box-beam attributes are shown in Table 5-2.

Table 5-2. Attributes of Precast Adjacent Box-beams Used in Michigan (Source: MDOT-BDM 2013)

	Depth range (in.)	Spans up to (ft)	28 day concrete strength (psi)
Box-beam (36 in. wide)	17 – 42	~120	5,000 – 7,000
Box-beam (48 in. wide)	21 – 60	~150	5,000 – 7,000

Some of the considerations related to the use of these elements are as follows:

- Fabrication complexity due to the multi-step fabrication process of the box,
- Inspection difficulties of the box-beam interior,
- Difficulty in accommodating utilities underneath the superstructure, and
- Difficulty in replacing an individual beam due to transverse post-tensioning.



Figure 5-8. Adjacent box-beams that require a wearing surface (Source: CPCI 2006)

5.1.4.2 *Inverted-T Precast Slab*

Description: The inverted-T precast slab elements are assembled adjacent to each other so that formwork is not required for casting the connections and the deck. The transverse reinforcement protruding from the precast elements provides the moment continuity across the connection (Figure 5-9). These elements have been used by the Minnesota DOT in several projects since 2005.

These elements are suitable for spans up to 65 ft (i.e., short span bridges). The typical width is 6 ft, and the depth is 30 in. (for elements of 65 ft span). The depth includes the 24 in. deep precast section and 6 in. thick CIP deck. Because of their shallow depth, these elements are ideal for sites with underclearance limitations. Concrete with a 28-day strength of 6,500 psi is commonly specified for these elements, and a 28-day strength of 4,000 psi is specified for the CIP deck.

Sources of information: Bell II et al. (2006); French et al. (2011).

Constructability evaluation: These elements require a reinforcement cage along the longitudinal joint with the CIP deck. The transverse reinforcement (Figure 5-9 and Figure 5-10) allows anchoring the preassembled reinforcement cage (Figure 5-11). The CIP deck

increases the project duration. The implementation of these elements in Minnesota has been limited to the short span bridges (20 ft to 60 ft).

The observed reflective cracking at the longitudinal joints was described as a durability concern. A recent NCHRP-10-71 project (French et al. 2011) investigated the performance of these elements. Moreover, the investigations revealed that the elements with depth greater than 22 in. require large amounts of confining reinforcement in the end regions. The time-dependent restraint moments in the full bridge system were identified to dominate the creep of individual elements. The NCHRP-10-71 project proposed design changes to account for the reflective cracking and bursting stresses at the end regions. The new but untested details for the inverted-T precast slab section are shown in Figure 5-10 and Figure 5-11 b.

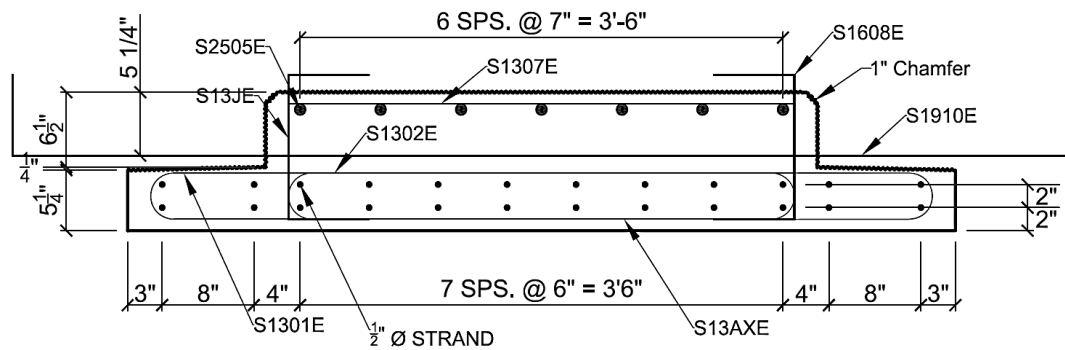

(a) End section

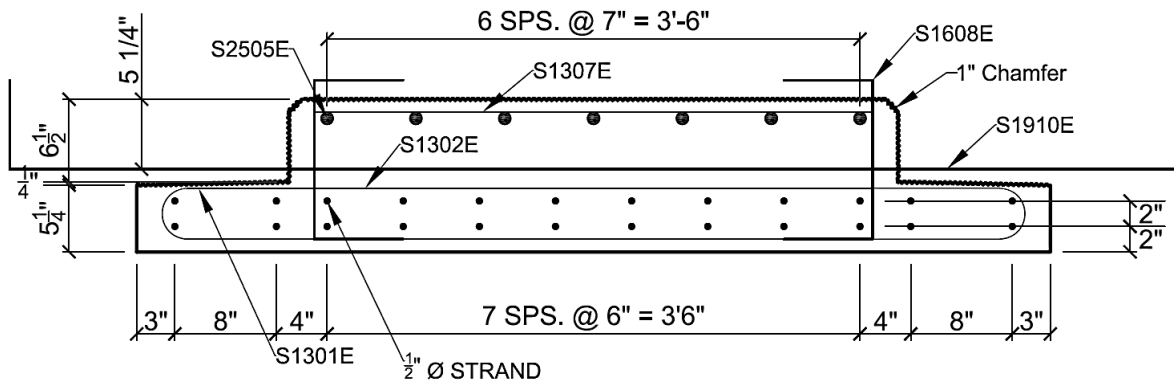

(b) Midspan section

Figure 5-9. Old detail of the inverted-T precast slab

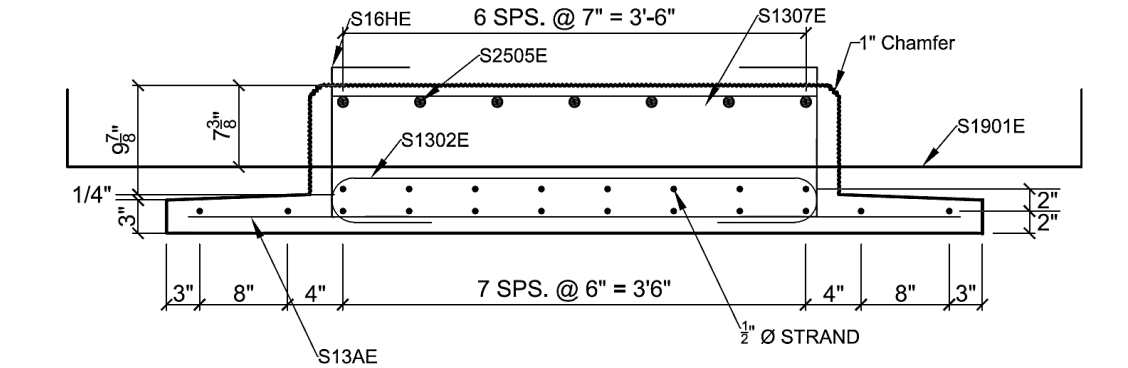

(a) End section

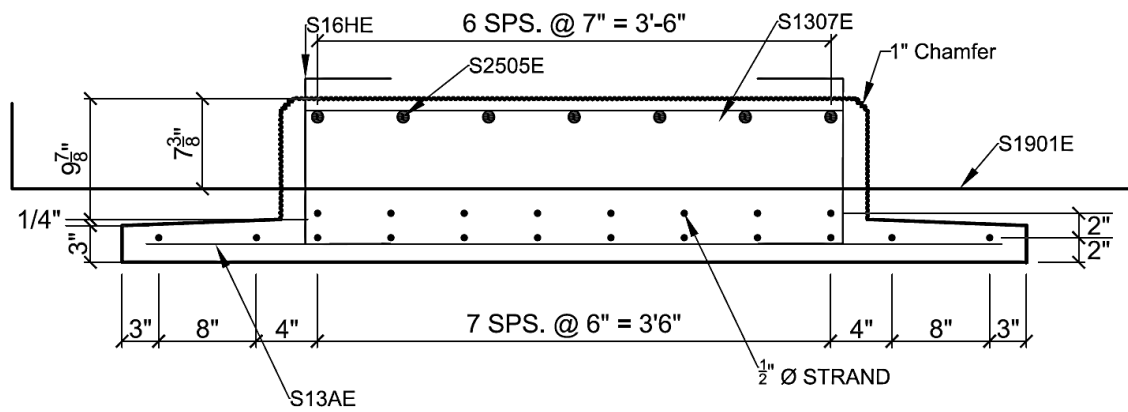

(b) Midspan section

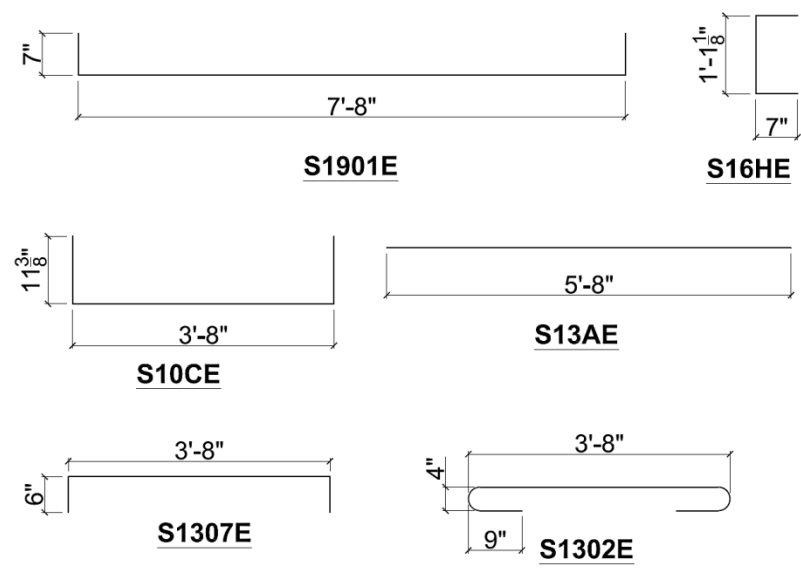

(c) Standardized reinforcing bars

Figure 5-10. New detail proposed by the NCHRP for the inverted-T precast slab

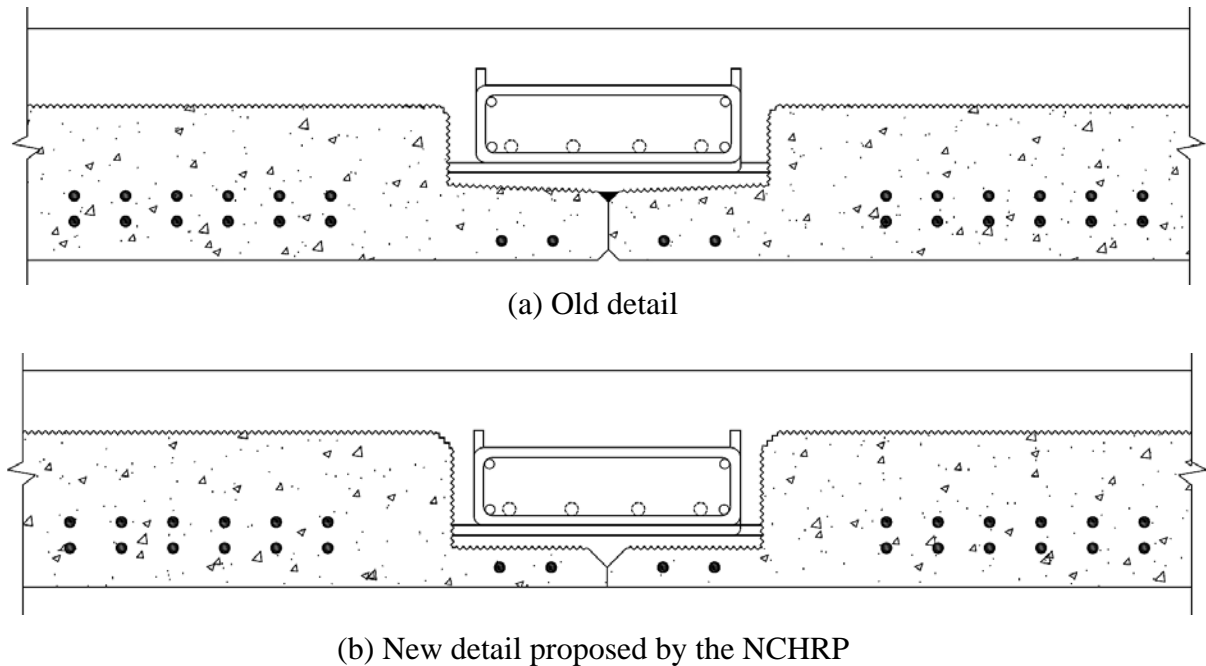

Figure 5-11. Reinforcement cage at longitudinal joint of the inverted-T precast slab

5.1.4.3 Northeast Extreme Tee (NEXT) D Beam

Description: The NEXT D beam is a modified version of the standard double tee girder. The NEXT D beam does not require a CIP deck and has a wider stem that can accommodate large number of prestressing strands (Figure 5-12). These elements have been designed for greater load carrying capacity than the standard double tee girders. This section is approved for use in Connecticut, Massachusetts, Maine, New Hampshire, Rhode Island, Vermont, Delaware, Maryland, and New Jersey.

The Precast Prestressed Concrete Institute Northeast chapter (PCI NE) has developed standard details for the NEXT D beam elements. (See Appendix H for details.) The NEXT D beam elements can be cast in a single pour. Also, standardized depth, spacing, and size of stems allow different element widths, ranging from 8 ft to 12 ft, to be produced with one set of formwork (Figure 5-12). The spans range from 40 ft to 90 ft, and the depth ranges from 24 in. to 36 in. at 4 in. increments. The NEXT D beam of 90 ft length weighs about 160 kips.

Sources of information: Calvert (2010); Culmo and Seraderian (2010); PCI NE (2011); Culmo (2011).

Constructability evaluation: The NEXT D beam elements are designed without intermediate diaphragms. The lack of the intermediate diaphragms may lead to undefined load distribution and excessive twist under live load.

The NEXT D beam elements and their connection details are new, and past performance data is limited. Durability performance of longitudinal connections between the elements needs to be evaluated. The potential connection details for such systems are discussed in Section 5.2.1.2 – Longitudinal Connection at the Deck Level.

The NEXT D beam consists of wide stems. This cross section is non-optimal which results in excess weight. Therefore, the use of these elements in bridge construction will be limited.

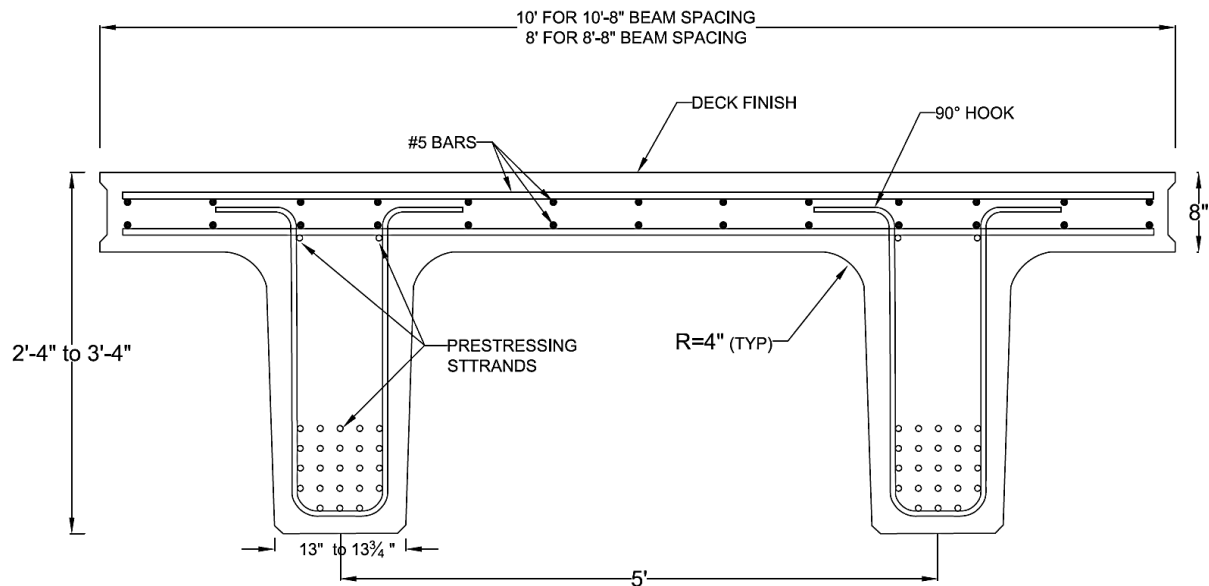

Figure 5-12. NEXT D beam element (Source: PCI NE 2011)

5.1.5 Modular Superstructure Systems

The modular superstructure systems presented in Appendix A include the INVERSET™ (proprietary) and the decked steel girder (non-proprietary). The recommended modular superstructure system for immediate implementation is described below

1. The decked steel girder system: This system is recommended because it is non-proprietary and fabrication is simple. The system is more suitable for bridges in non-corrosive environments. This system requires a wearing surface to enhance durability once assembled on-site.

5.1.5.1 Decked Steel Girder System (Also Referred as Decked Steel Girder Module)

Description: The decked steel girder system was developed in a SHRP II project; it was implemented in the I-93 Fast 14 project in Medford, MA (MassDOT 2011) and the Keg Creek Bridge replacement project in Pottawattamie County, IA (IowaDOT 2011).

The modules consist of two W 30x99 (depth: 29.7 in.), ASTM A709 grade 50W steel girders, integral with a 7.5 in. to 8 in. deep precast deck (Figure 5-13). The section width ranges from 8 ft to 9 ft with a 28-day compressive strength of 4000 psi to 5000 psi. Up to 73 ft spans have been implemented with the section details shown in Figure 5-13.

Sources of information: Shutt (2009); LaViolette (2010); MassDOT (2011); IowaDOT (2011); Moyer (2011).

Constructability evaluation: Manufacture of this module requires steel fabricators and precasters to work together. The crown of the decked steel girder bridge could be formed in two ways: i) increasing the thickness of the deck, and diamond grinding part of the deck to the desired crown, and ii) placing an overlay over the deck to form the crown.

Use of weathering steel can help with corrosion prevention. However, the system, even with weathering steel, is not suitable for Michigan exposure with aggressive winter maintenance. The past performance data of the decked steel girder system is limited. The success of the decked steel girder system is controlled by the performance of the longitudinal connections. The recommended longitudinal deck connection details and continuity details over the piers

and abutments are discussed in Section 5.2.1.2 – Longitudinal Connection at the Deck Level and Section 5.2.1.4 – Continuity Detail over the Pier or a Bent.



(a) Section elevation

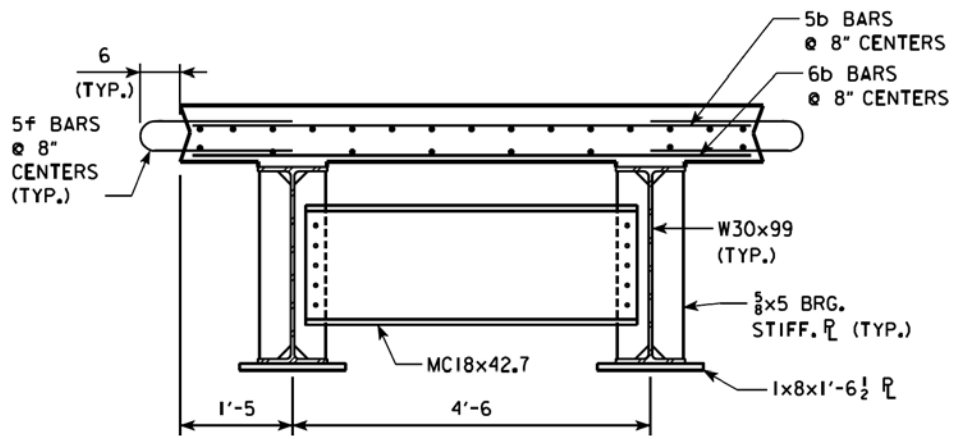

(b) Section details

Figure 5-13. Decked steel girder system (Source: MassDOT 2011; IowaDOT 2011)

5.1.6 Substructure Elements and Reduced-Weight Options

Since the inception of ABC, several substructure elements and connection details have been developed. The substructure elements that were identified during the literature review are presented in Appendix A.

Transport and placement impose limits to the weight of prefabricated components. For example, the MDOT-BDM (2013) Section 7.01.19 recommends limiting weights of PBES to 80 kips (40 tons) for safe handling using conventional equipment. Due to similar constraints, the ABC Toolkit developed under the SHRP2 R04 project (SHRP2 2012) recommends limiting weights to 160 kips (80 tons). Where site conditions allow, SHRP2 (2012) suggests using PBES up to 250 kips (125 tons) to build longer spans or wider bridges to minimize construction duration.

Generally, the substructure is considered bulky and heavier compared to the girders. According to Table 2-1, a span length greater than 50 ft with decked bulb-tee and decked box-beam sections with 9.5 in. thick flange cannot be attained when the PBES weight is limited to 40 ton (80 kips). In other words, bridge span and girder type also need to be considered when defining weight limits for substructure components. Options are available for reducing substructure element weight. Generally, the section weight can be reduced by removing the material that does not contribute to section capacity or the stiffness, applying prestressing or post-tensioning, or a combination thereof.

The substructure elements that show potential for immediate implementation are as follows:

1. Precast abutment walls and stems: Use of precast abutment walls and stems are recommended. Some of the recommended stem sections are cast with cavities to reduce weight. Additionally, segmental stems are recommended for sites with limited access for large equipment.
2. Precast column: Octagonal and square/rectangular columns are recommended. These precast columns are preferred because they do not require vertical casting and are easy to secure during transportation. Segmental columns with precast hollow sections are recommended for sites with limited access for large construction equipment.

3. Precast pier/bent cap: The recommended bent caps include the rectangular and the trapezoidal shapes. These bent caps are preferred because they reduce the number of required substructure elements (i.e., columns and footings). In addition, a bent cast with cavities, tapered sections, or a combination thereof is recommended for reduced weight.

5.1.6.1 Precast Abutment Walls and Stems

Description: The precast abutment walls and stems were used in several ABC projects in the U.S. Use of walls or stems depends on the site condition. An example project with an abutment wall is the M-25 over the White River Bridge in Michigan (Figure 5-14). The precast abutment walls are used with spread footing while the stems are used with piles. The abutment wall on spread footing is also known as a cantilever abutment.

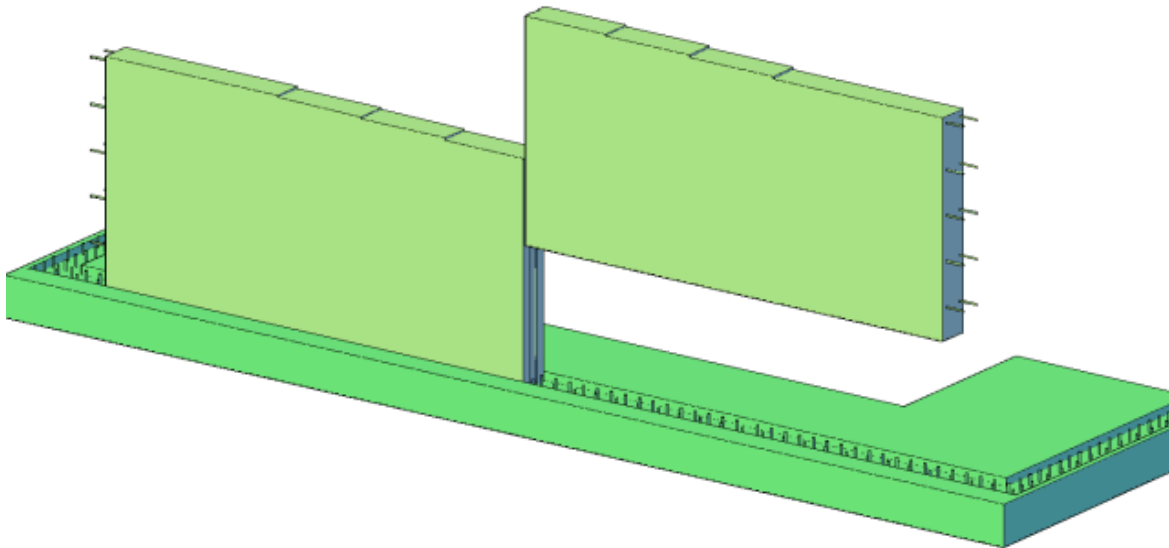

Figure 5-14. Abutment wall on spread footing (Source: MDOT M-25 over White River Bridge Plans)

For sites requiring a spread footing, the precast abutment wall is usually cast in segments to help with shipping and handling of the component. For sites requiring piles, the precast abutment stem is cast either in segments or as a single element based on site constraints. Another option of reducing abutment stem weight is to use redundant pile cavities to be filled in the field (Figure 5-15).

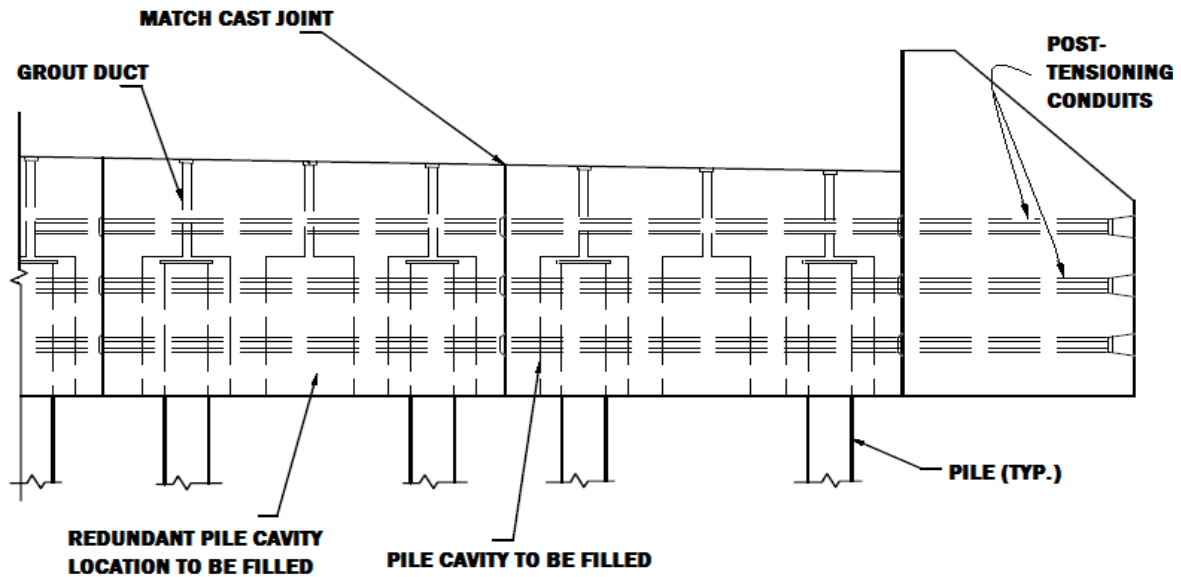

Figure 5-15. Segmental abutment with redundant pile cavities (Source: Culmo 2009)

The abutments can be designed as integral or semi-integral. The semi-integral abutment is recommended because of the following: (1) placing the prefabricated superstructure is simpler on the constructed abutment, (2) the semi-integral abutment provides access for inspection and maintenance of the bearing, (3) future superstructure repair and replacement activities can be accommodated, and (4) the semi-integral abutment simplifies substructure design especially in high-skew bridges.

The height of a precast abutment wall varies from 4ft to 10ft, and its thickness is around 2 ft. Precast abutment stem height and thickness vary between from 3 ft and 4 ft, and the length can be up to 14 ft. The typical 28-day compressive strength used in precast substructure elements varies from 4,000 psi to 5,000 psi.

Sources of information: Stamnas and Whittemore (2005); MDOT M-25 over White River Bridge plans (2010); Culmo (2009); UDOT (2010b).

Constructability evaluation: For sites requiring spread footings, the abutment walls are placed into the channel cast in the spread footing. Connectivity is achieved through grouted splice-sleeve connection. Tight tolerances are required for the proper fit of the precast elements while using grouted splice sleeve connections. Refer to Section 5.2.2.3 – Abutment Wall to Footing Connection for design details and potential strategies for improved constructability.

In sites requiring piles, tighter tolerances are required for the pile driving operation when a precast abutment stem is used. A steel template is commonly used to assure accuracy of pile placement (Figure 5-16). The abutment stems are connected to the piles using various types of grouted connections. (See Section 5.2.2.1 – Pile Cap or Abutment Stem to Pile Connection for details.) During the abutment stem placement over the piles, for leveling, a gap needs to be maintained between the end of the pile and the precast abutment stem. With this gap, maintaining a proper grade with the abutment stem is difficult. To maintain the grade, a CIP concrete slab on grade can be placed as shown in Figure 5-17.

Post-tensioning is commonly specified for abutment stems casted in segments. Other vertical connection details without post-tensioning are discussed in Section 5.2.2.5 – Vertical Connection between Elements. Grouting of the vertical shear keys between the abutment segments (i.e., splices) (Figure 5-14) needs further study. Projects have reported joint forming and sealing difficulties under significant pressure head due to the height of the abutment stem.

Moreover, when the redundant pile cavities (Figure 5-15) are used in an abutment stem to reduce the weight, the formwork to form the cavity may create difficulties during the casting process. Grouting large cavities will be difficult because of fill depth limits of most grouts. The use of concrete and special concrete mixes for filling cavities in substructure elements needs to be investigated.



Figure 5-16. Template used for maintaining pile driving tolerances (Source: Photo courtesy of MDOT)



Figure 5-17. Concrete slab on ground to maintain the proper grade for placing the abutment stem (Source: Photo courtesy of MDOT)

5.1.6.2 Precast Columns

Description: Precast columns of circular, I-shape, octagonal, square/rectangular, and oval-shape have been implemented in various projects. The oval-shape is typically used for the piers of long and wide bridges. The I-shape is typically used for the piers of tall structures where increased lateral stiffness is required. For the short and short-to-medium span bridges, the circular, square/rectangular, and octagonal shapes are used.

According to the precast industry, a circular cross-section can only be cast in vertical position which creates difficulties. For that reason, New England states, Florida, Texas, and Utah prefer using octagonal precast columns. Other states such as Iowa, Washington, and California use square/rectangular precast columns. If needed, there are various ways of casting circular sections in horizontal position as accomplished by the concrete pole industry's centrifuge casting.

The octagonal columns (Figure 5-18) and square/rectangular columns (Figure 5-19) are easy to fabricate and are more stable during the shipping and handling process.

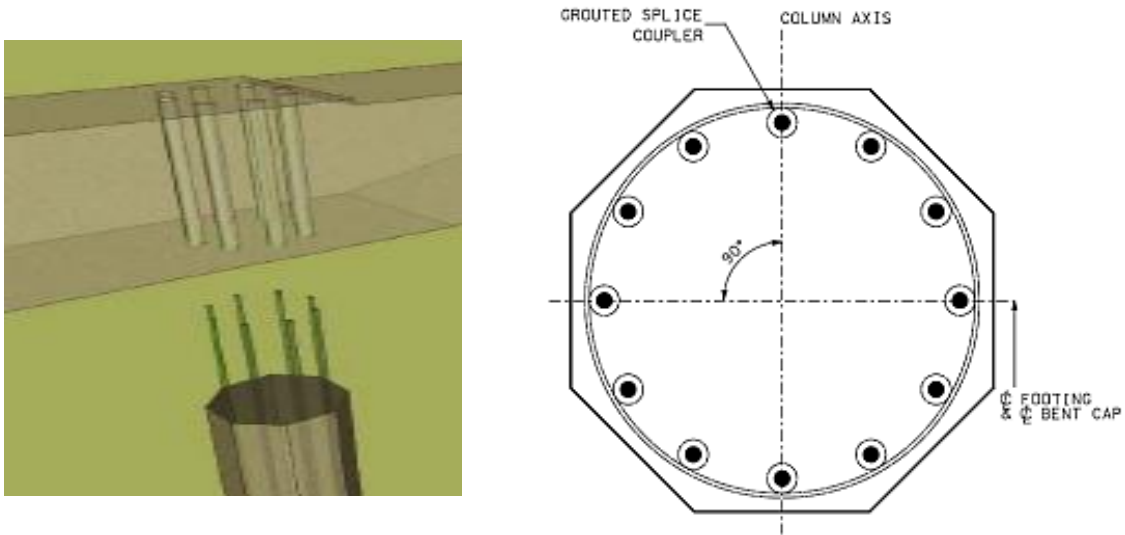

Figure 5-18. Octagonal column (Source: UDOT 2010b)



Figure 5-19. Square/Rectangular column (Source: IowaDOT 2011)

Sources of information: Shahawy (2003); UDOT (2010b); Khaleghi (2011).

Constructability evaluation: The octagonal and rectangular precast columns can be fabricated in horizontal position, thus providing flexibility by using long forms to provide the ability to cast multiple columns at once. Higher strength concrete can be specified, and prestressing can be used to achieve taller and more durable precast columns.

Specified tolerances need to be stricter for column connections to footings and to bent caps. Refer to Section 5.2.2.2 – Column to Footing Connection and Section 5.2.2.4 – Pier Cap or Bent Cap to Pier or Column Connection for design details and potential strategies to mitigate constructability issues.

Transporting columns may create difficulties depending on the height and weight. A rectangular precast column with a similar load carrying capacity to an octagonal column has a greater weight.

5.1.6.3 Precast Pier/Bent Cap

Description: The precast pier/bent caps are common prefabricated substructure elements that distribute the load from the bridge superstructure uniformly to the foundation. The commonly specified bent cap geometries are: i) rectangular (Figure 5-20) and ii) trapezoidal (Figure 5-21). The bent caps are useful for the bridge sites crossing power/utility lines, waterways, and highway-rail grade crossings. The use of bent caps minimizes the required number of columns and footings.

Usually, one bent cap is used to support the full-width of the superstructure, whereas multiple trapezoidal bent caps are used for the full-width (Figure 5-21). The typical height of a bent cap is 3 ft to 4.5 ft, and the width is 3 ft to 4 ft.

The UDOT (2010b) standardized the bent caps as: i) single column hammer head bent (Figure 5-22 a), ii) two column bent (Figure 5-22 b), and iii) three column bent (Figure 5-22 c). Any combination of any of two or three column bent caps is used to support the full-width of a superstructure (UDOT 2010b).



Figure 5-20. Rectangular bent cap (Source: <http://facilities.georgetown.org/2009>)



Figure 5-21. Trapezoidal bent cap (Source: Restrepo et al. 2011)

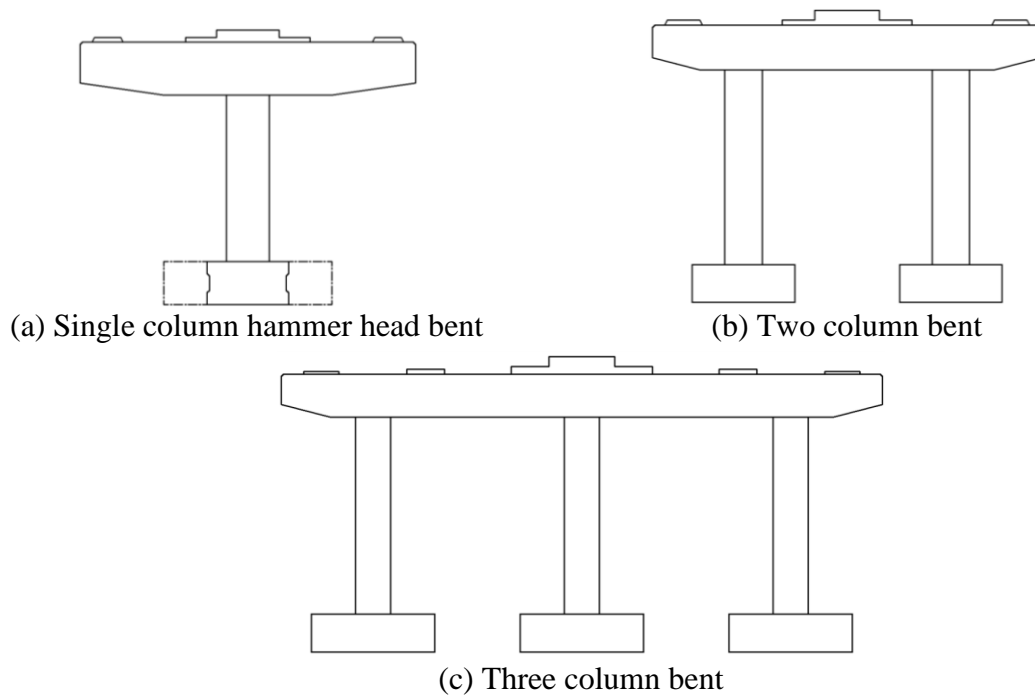

Figure 5-22. UDOT standardized bent cap sections (Source: UDOT 2010b)

Sources of information: LoBuono (1996); Billington et al. (1999); Matsumoto et al. (2001); Ralls et al. (2004); UDOT (2010b); Restrepo et al. (2011).

Constructability evaluation: The bent cap weight needs to be considered for transport and handling.

Depending on the type of connection for the bent cap to column or pier cap to pier, the specified tolerances needs to be stricter. Refer to Section 5.2.2.4 – Pier Cap or Bent Cap to Pier or Column Connection for design details and potential strategies to mitigate construction challenges.

Prestressing may be used to reduce the height and weight of the element. A precast inverted-T bent cap was proposed by Billington et al. (1999), which can be prestressed (Figure 5-23 a, b) to achieve shallow depth and extended length of up to 42.5 ft. Also, the section geometry can be optimized to reduce the weight of the bent cap (i.e., reducing the section around the center of the cap and bottom corners of the flange, Figure 5-23 c, d). The recommended design with web walls of 14 in. thickness provides sufficient cover, anchorage zone, and shear reinforcement in the bent cap. Implementation of the inverted-T bent cap could not be identified. Further study is required to establish the applicability of the details proposed by Billington et al. (1999).

Another approach to reduce the weight of the bent cap element is to eliminate a section using embedded corrugated metal casing. Refer to Section 5.2.2.1 – Pile Cap or Abutment Stem to Pile Connection for design details. The approach needs further analysis before being considered for implementation.

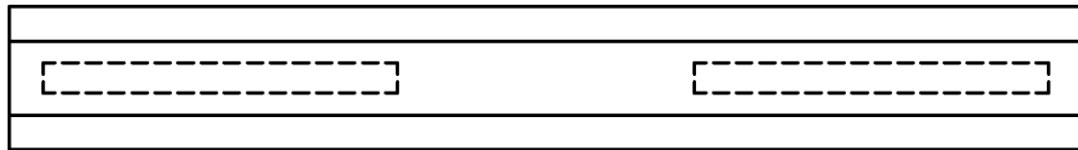

(a) Plan view

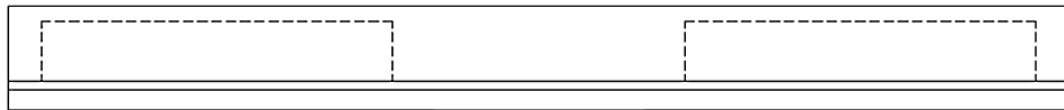

(b) Elevation view

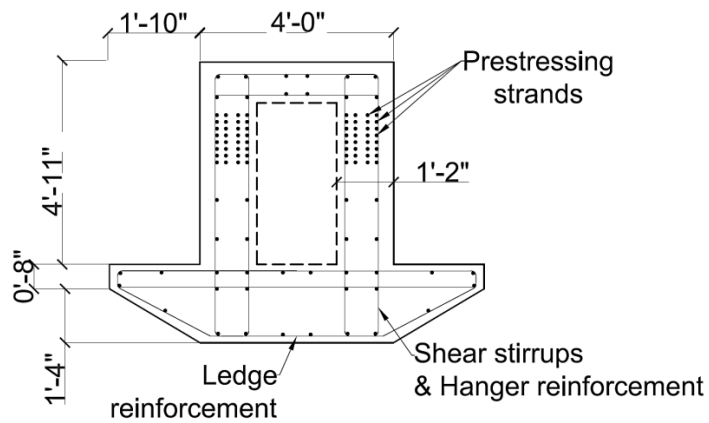

(c) Section through the cantilever portion

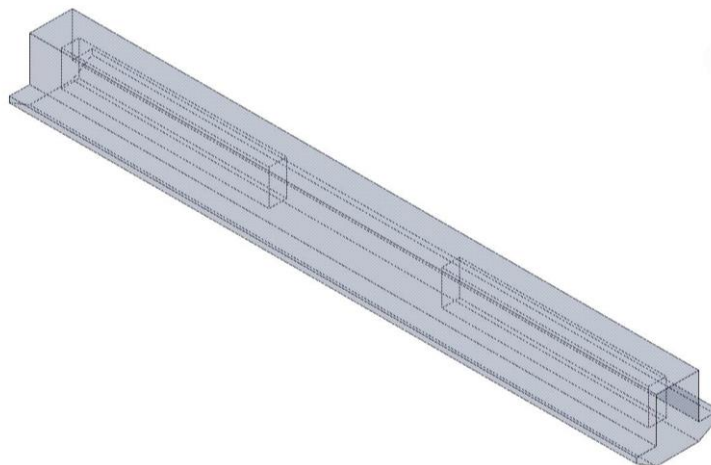

(d) Isometric view showing the voids

Figure 5-23. Inverted-T prestressed bent cap (Source: Billington et al. 1999)

5.1.7 Substructure Elements with Implementation Potential

Some of the substructure elements that are presented in Appendix A may have a potential for implementation. The substructure elements used in limited number of projects are

1. Precast bent cap cast with cavities or tapered sections
2. Precast segmental columns.

5.1.7.1 Precast Bent Cap Cast with Cavities or Tapered Sections

Description: This bent cap (Figure 5-24) was implemented in 2001 in the Conway Bypass Highway Bridge in Horry County, South Carolina. The bent cap weight was reduced by including cavities.

In the Conway Bypass Highway Bridge project, each bent cap with a square cross-section supported the full-width of the superstructure. The depth and width of the bent cap were about 4 ft with a specified 28-day compressive strength of 5000 psi. Cross-section details were not available in the literature. The design and cross-section details need to be investigated.



Figure 5-24. Precast bent cap with cavities (Source: Culmo 2009)

Potential weight reduction using a doubly reinforced concrete section, a component with embedded cavity, and a component with tapered cantilevers was evaluated (Figure 5-25). A 25% weight reduction can be achieved by using doubly reinforced concrete sections when compared to a singly reinforced section (Table 5-3). Use of a cavity and tapered cantilever helps reduce weight by 16% when compared to a singly reinforced section.

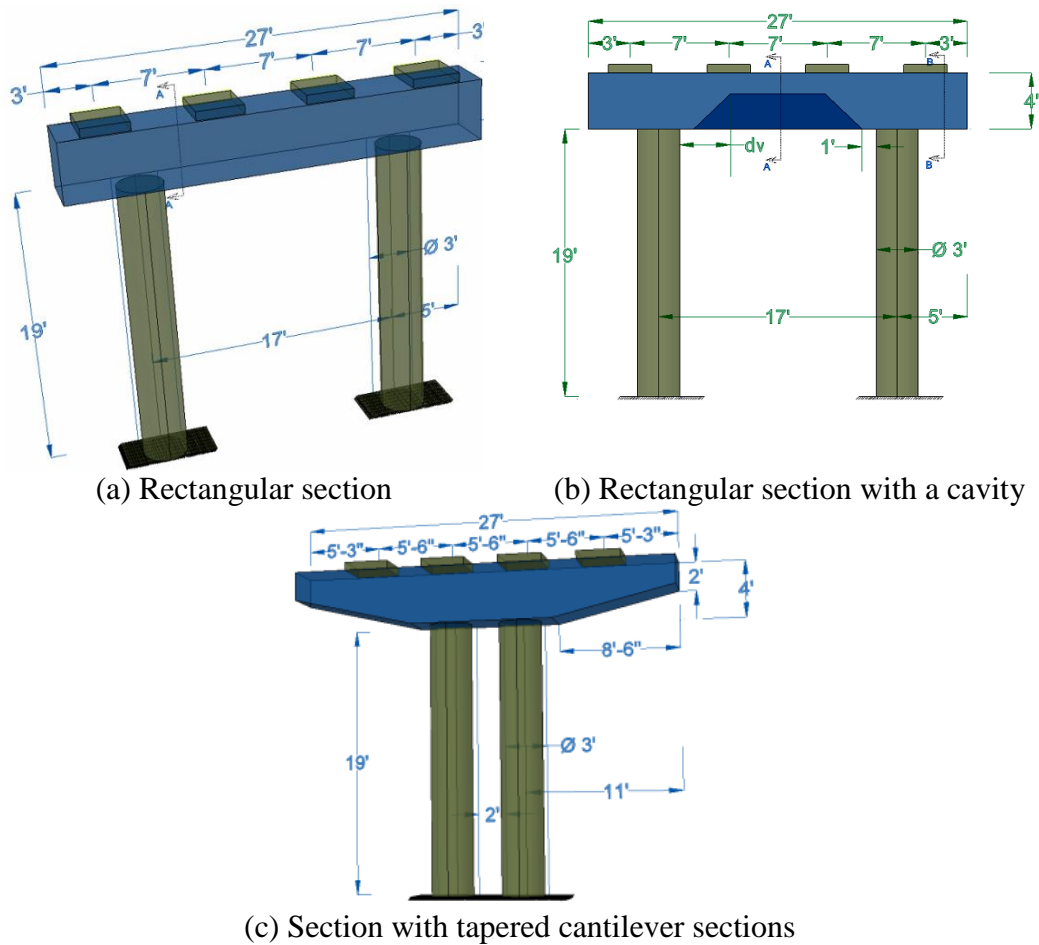

Figure 5-25. Bent cap configurations

Table 5-3. Comparison of Bent Cap Weight Reduction

Bent Configuration	Volume (ft ³)	Weight (kips)	Wt. Reduction (%)
Standard rectangular (singly reinforced design)	378.0	56.7	-
Rectangular (doubly reinforced design)	283.5	42.5	25.0
w/ Cavity	317.5	47.6	16.0
w/ Tapered cantilever	318.5	47.8	15.7

Sources of information: Shahawy (2003); Culmo (2009).

Constructability evaluation: Fabrication and reinforcement detailing of the bent cap with cavities may create difficulties. Potential connection details of the bent cap to the column are

discussed in Section 5.2.2.4 – Pier Cap or Bent Cap to Pier or Column Connection. Prestressing can be an option to further reduce the cross-section dimensions.

5.1.7.2 Precast Segmental Columns

Description: A hollow precast segmental column was designed by Billington et al. (2001) under the sponsorship of FHWA and Texas DOT. The columns consist of multiple precast segments and a template (capital) (Figure 5-26 a). The desired column height could be achieved by increasing/ decreasing the number of segments and segment heights. The weight of each segment can be limited to allow ease in transporting and placing. The precast template (Figure 5-26 a) helps with aligning the pier with the bent cap or girder elevation. The hollow section of the segment (Figure 5-26b) can accommodate drainage ducts. Girders can be directly placed on the segmental columns to eliminate the bent cap (Figure 5-27).

The precast segmental column was implemented in a short-span bridge project in Texas (U.S. Highway 249 over Louetta Road in Houston). No other implementation was documented in the literature. Because of limited application and lack of performance data, further review is recommended before specifying these substructure elements.

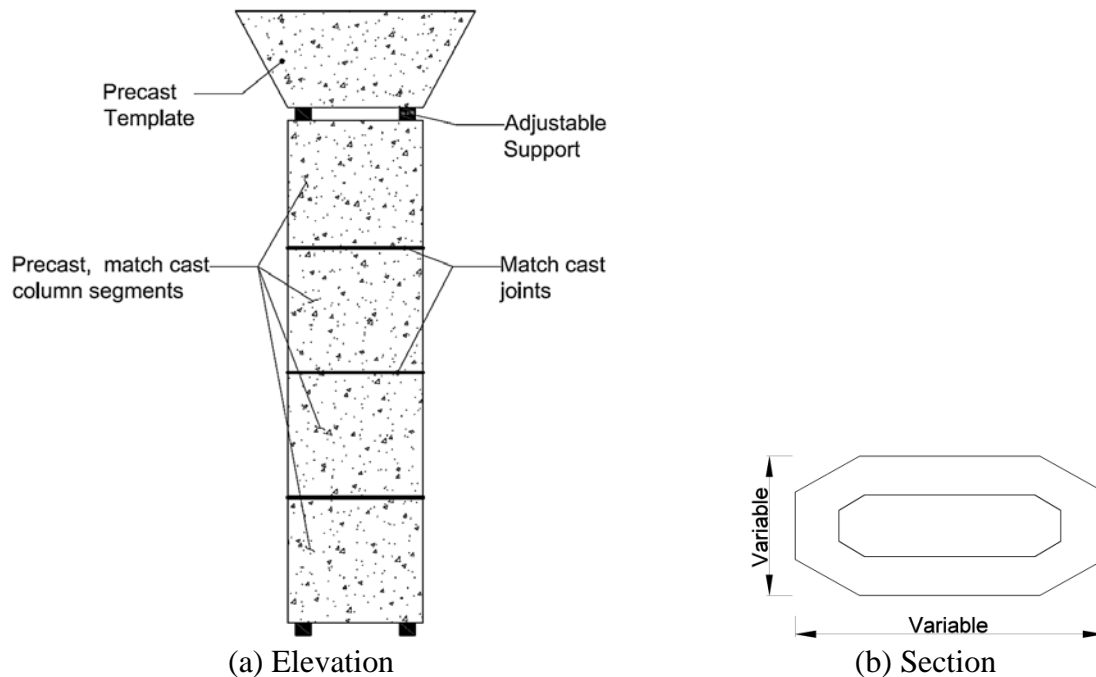

Figure 5-26. Precast segmental column (Source: Billington et al. 2001; Shahawy 2003)



Figure 5-27. Short-span bridge with precast segmental columns (Source: Shahawy 2003)

The precast segmental column characteristics are as follows:

- Length of each segment 3 ft to 6 ft,
- Depth of cross-section 4 ft to 10 ft,
- Width of cross-section is 4 ft, and
- Specified 28-day compressive strength is 5000 psi.

Sources of information: Billington et al. (2001); Shahawy (2003); PCI (2011).

Constructability evaluation: The precast template (capital) is aligned with the bent cap or girder elevation with adjustable supports on the top segment of the precast segmental column. High-strength epoxy grout is specified for the joint between the precast template and the top segment of column. The match-cast joints between the segments allow for an accelerated construction process. However, for using match-cast joints, each segment must be labeled for identification. There are two possible connection details for the precast column segments: i) grouted splice coupler connection and ii) vertical post-tensioning. (See Section 5.2.2.6 – Connection between Segmental Columns or Piers for details.)

To minimize the segment weight, a suitable section type and size needs to be developed for short and short-to-medium span bridges. This requires further review before implementation.

5.2 CONNECTION DETAILS

5.2.1 Recommended Superstructure Connection Details

The following connection details are recommend to be used in the State of Michigan. Recommendations are based on (1) exposure conditions in Michigan, (2) load transfer demand, (3) constructability, (4) connection dimensions and tolerances (to ensure construction quality) and (5) other required details such as formwork.

5.2.1.1 *Transverse Connection at the Deck Level*

The transverse connection between panels is typically unreinforced, and requires post-tensioning for transfer of both moment and shear. Following the grouting, the panel joints can be compressed by longitudinal post-tensioning. Panel tolerances must be specified so that post-tensioning only compresses the grout and avoids transfer through panel-to-panel contact. To accommodate some duct misalignment and ease of placing tendons, generally a 2-in. circular post-tensioning duct is recommended for this purpose. The post-tensioning schedule needs to accommodate the strength development rate of the joint grout in between panels. A grout material with a modulus of elasticity comparable to the deck panel concrete is recommended for the panel joints at the transverse connection for a uniform distribution of clamping stress (Ulku et al. 2011).

The details shown in Figure 5-28 are recommended instead of the details presented in Figure 5-29 . This recommendation is based on the required tolerances, space for ensuring proper grouting, and adequate confinement for the material to transfer shear. The connection detail shown in Figure 5-29 has been used with a specified tolerance of $\frac{1}{4} \pm \frac{1}{4}$ in. between the bottom edges of the panel, which may result in zero tolerance and panel to panel contact. In the case of panel-to-panel contact, the post-tensioning forces will be transferred at contact locations without compressing the grout. For this reason, the tolerance is increased to $\frac{1}{2}$ in. as shown in Figure 5-29. Figure 5-30 shows the details at post-tensioning tendon coupling locations. As discussed in Section 2.4, grout void dimensions are one of the parameters that need to be considered in selecting grout. A larger void (fill depth) requires using extended grouts or special concrete mixes to avoid high heat of hydration. The extended grouts, or special mixes, have slower rate of strength development and will increase the construction

duration. Neat grout that has a maximum fill depth limit of 6 in. is suitable for the connection cavity shown in Figure 5-28. Also, proper grout curing and protection practices need to be exercised as per the manufacturer's recommendations.

There should be a sufficient gap in panel connections to eliminate panel-to-panel contact. Flexible material such as a foam backer rod is commonly used to seal the bottom of the joint. The foam backer rod can be attached to one of the panels before being placed. Further, foam backer rods can accommodate panel surface irregularity at the joint. The foam backer rod following installation should be able to withstand the self-weight of grout and any additional pressure due to the application procedures such as pumping.

The connection detail recommended for the deck panels can also be specified for the longitudinal connections such as a decked bulb-tee, double-tee, decked box-beam, or any modular superstructure system. The difficulty expressed by the bridge designers with this connection detail is the use of post-tensioning. The reason for the difficulty is the complexities created by the post-tensioning during bridge deck repair, rehabilitation, and replacement activities. On the other hand, post-tensioning essentially seals the joint and improves system durability.

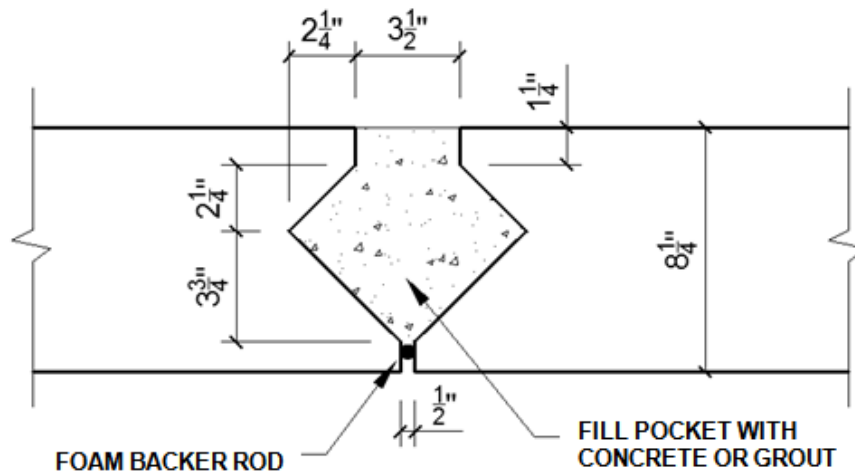

Figure 5-28. Diamond shaped transverse connection details between panels (Source: Culmo 2009)

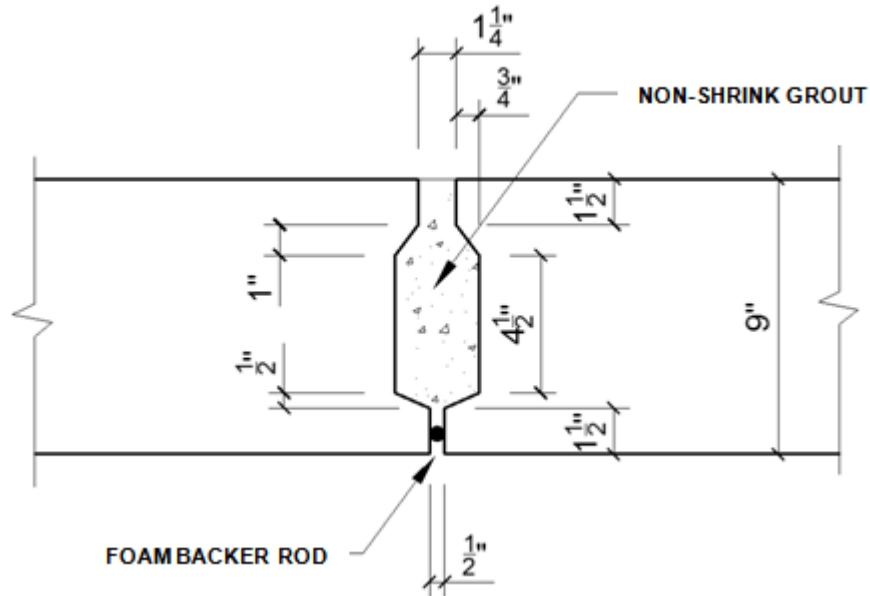

Figure 5-29. Transverse connection details of a grouted shear key

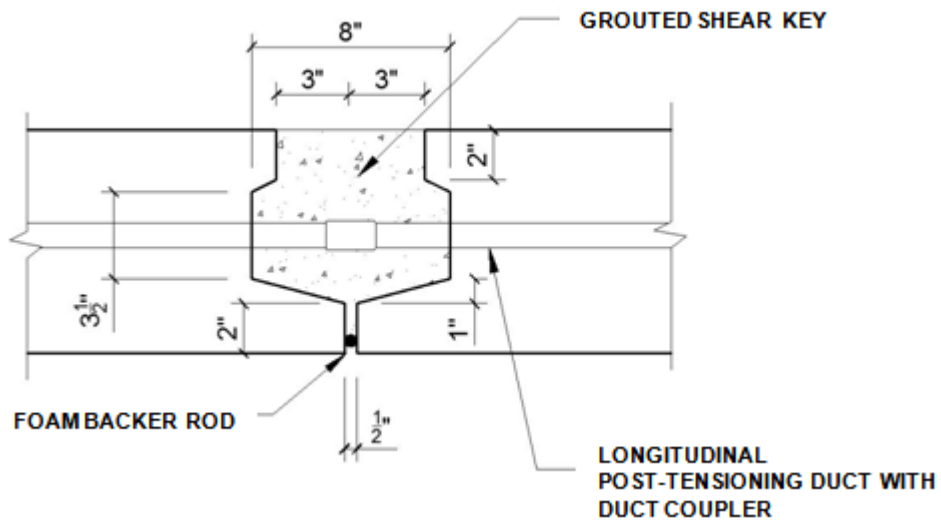

Figure 5-30. Transverse connection detail of a grouted shear key with longitudinal post-tensioning duct coupling

5.2.1.2 Longitudinal Connection at the Deck Level

There have been numerous ABC projects that successfully utilized longitudinal connections at the deck level. In all cases, the connection design was empirical, and guidelines are not available for rational design incorporating all effects including the thermal gradient loads.

In this project, in order to evaluate the connection capacities under all load effects, the longitudinal connection behavior with respect to its design parameters was analyzed. Utilizing the analysis results connection was rationally designed, and standard details were developed incorporating the load demands (i.e., moment, shear, and axial force) under live and temperature gradient loads. The parameters considered in the analysis are (1) bridge width, skew and span length, (2) girder size, spacing, and flange thickness, (3) end and intermediate diaphragm configuration, (4) intermediate diaphragm spacing, and (5) the material properties of superstructure components.

Load demands include only positive and negative thermal and live loads. Michigan is located in zone 3 as defined in the AASHTO LRFD (2012). A temperature of $T_1 = 41$ °F and $T_2 = 11$ °F, as specified in the AASHTO LRFD Table 3.12.3.-1, defined the gradient profile. Negative temperature values are obtained by multiplying the positive values by -0.3.

Live loads are specified in MDOT-BDM (2013) Section 7.01.04, which references AASHTO LRFD Article 3.6.1.2. This includes the exception that the design tandem, as specified in section 3.6.1.2.3, shall be replaced with a 60 kip single axle. Also, for Michigan interstate and trunkline bridges, vehicular live loading designated as HL-93Mod, is specified as 1.2 times the combination of the

- Design truck or 60 kip single axle load and
- Design lane load.

Temperature gradient generates considerably larger moments and forces due to internal and external constraints. The impact of each parameter on the moment, shear and axial load demand was evaluated. Moment and force envelopes were developed based on the critical parameters. The analysis process and the associated critical parameters are shown in Figure 5-31.

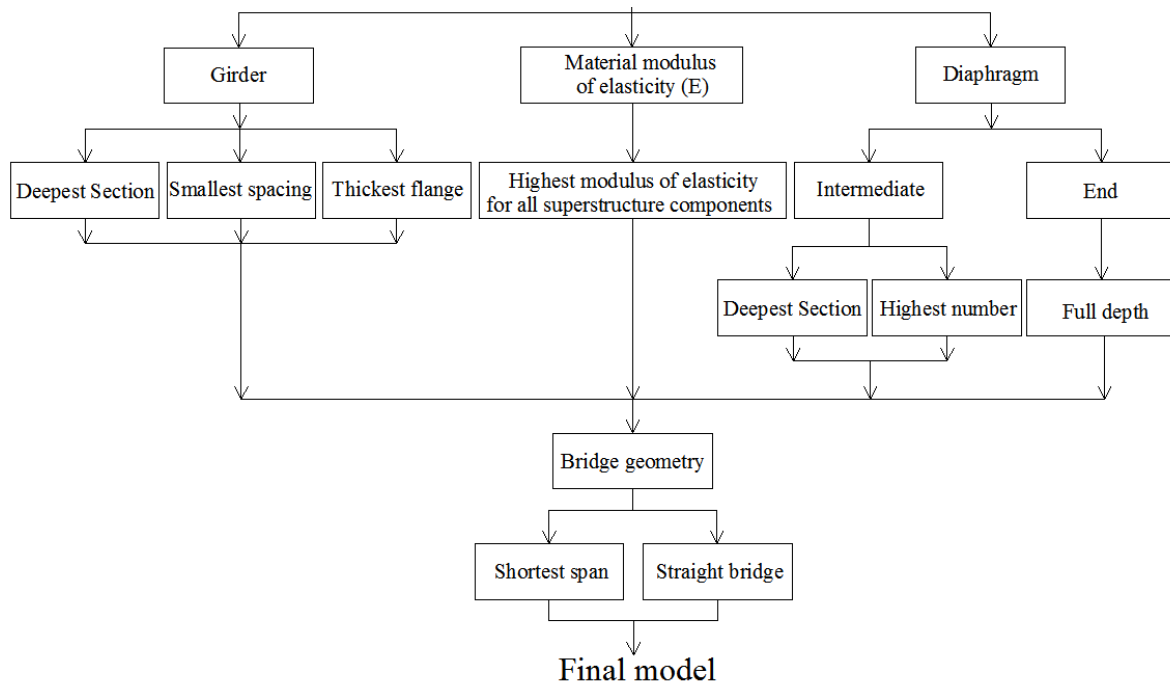
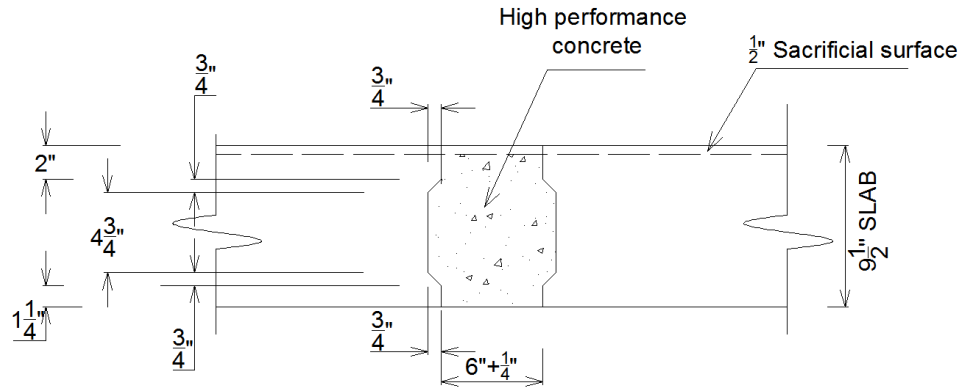
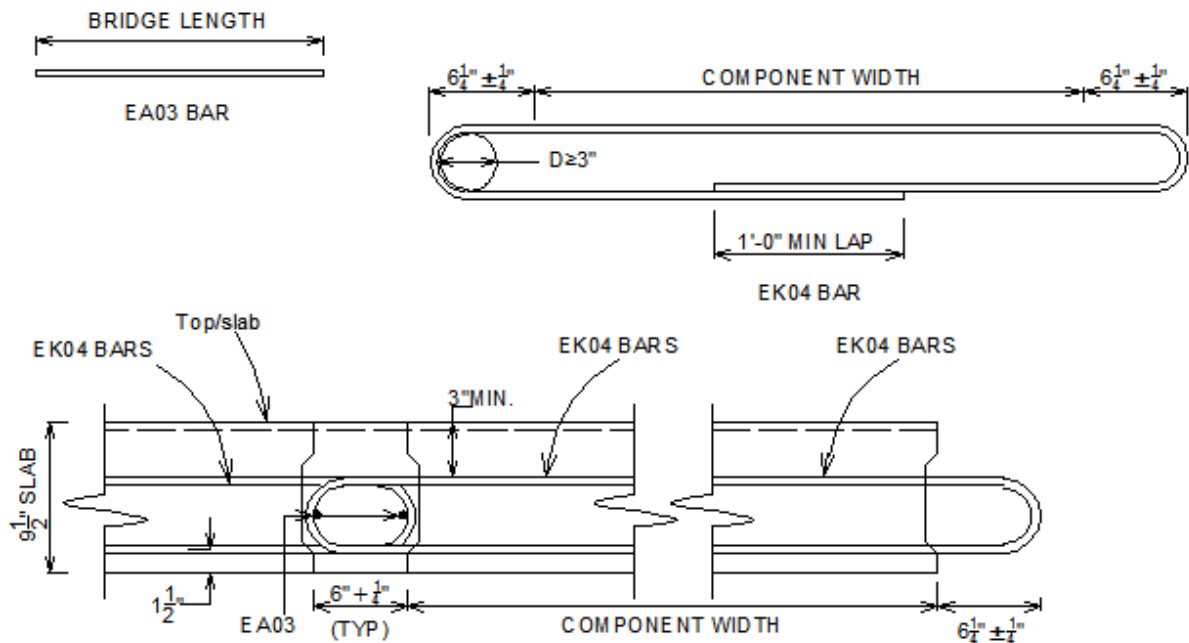

Figure 5-31. Critical design parameters for longitudinal connection at the deck level

The connection designed based on the rational process is shown Figure 5-32. These details are appropriate for bridge superstructures with precast girders and concrete decks. The details presented in Figure 5-32 are applicable to only unremarkable bridges with typical prestressed concrete girders such as I, box, bulb-tee, and MI-1800. The standard details are also presented in Appendix I in a format compatible with the Michigan Bridge Design Guide.



(a) Deck slab and connection dimensions



(b) Connection details

Figure 5-32. Standard details for the longitudinal connection at the deck level

The connection can be cast with high early strength concrete or grouts with an elasticity modulus comparable to concrete. The formwork for the connection needs to be designed to retain the material and prevent any leakage. The formwork needs to be designed to carry the weight of closure material and can be mounted as shown in Figure 5-33. In a majority of the cases, the formwork can be attached along the edge of prefabricated element prior to installation. Spray foam can be used to seal the gaps between the formwork and the concrete slab.

One of the difficulties associated with this connection detail is the space available for the reinforcement. One approach is to stagger the reinforcement as indicated in the MDOT-BDM (2013) Section 7.01.19.

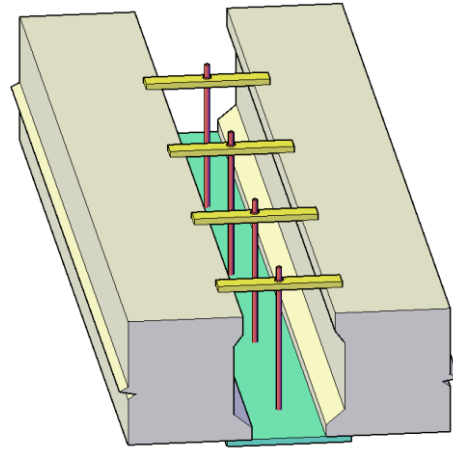

(a) 3D-view of the hanging formwork (reinforcement not shown for clarity)

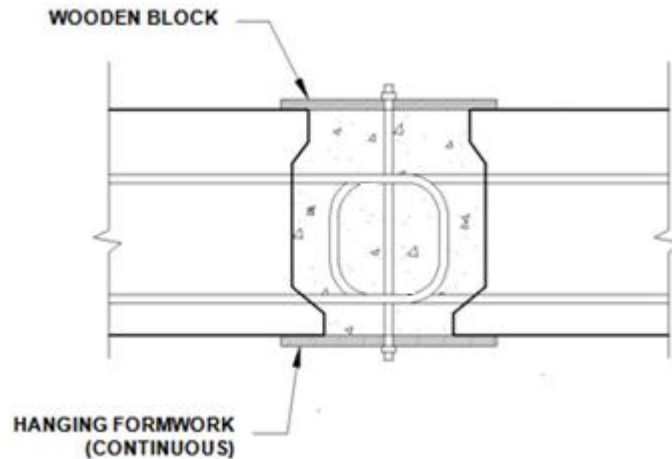

(b) 2D-section of hanging formwork with longitudinal closure reinforcement

Figure 5-33. Hanging formwork for longitudinal connection at deck level

5.2.1.3 Deck-to-Girder Connection - Blockouts

The blockout in the deck panels to establish the connection between the deck and steel girder is shown in Figure 5-34. The blockout is formed with rounded corners and tapers through the depth. A blockout with rounded corners is preferred to minimize the potential for developing air pockets during grouting, and to reduce stress concentrations within the connection under thermal and shrinkage loads. The tapered grouted cavity also prevents potential uplift of the panel. Steel studs can be welded to the steel girders on site or before being transported to site.

The formwork recommended for these connections is fabricated from flexible foam. Leveling devices are required to be used in conjunction with the flexible foam to maintain the proper panel elevation and to keep the foam compressed to prevent grout leakage.

The recommended deck and precast concrete girder connection is shown in Figure 5-35. Implementation of this detail is simple as the coil bolts are threaded into the flared coil on site. In any case, tolerance specifications for girder sweep, blockout size and location, and a quality control process are critical to avoid potential construction difficulties.

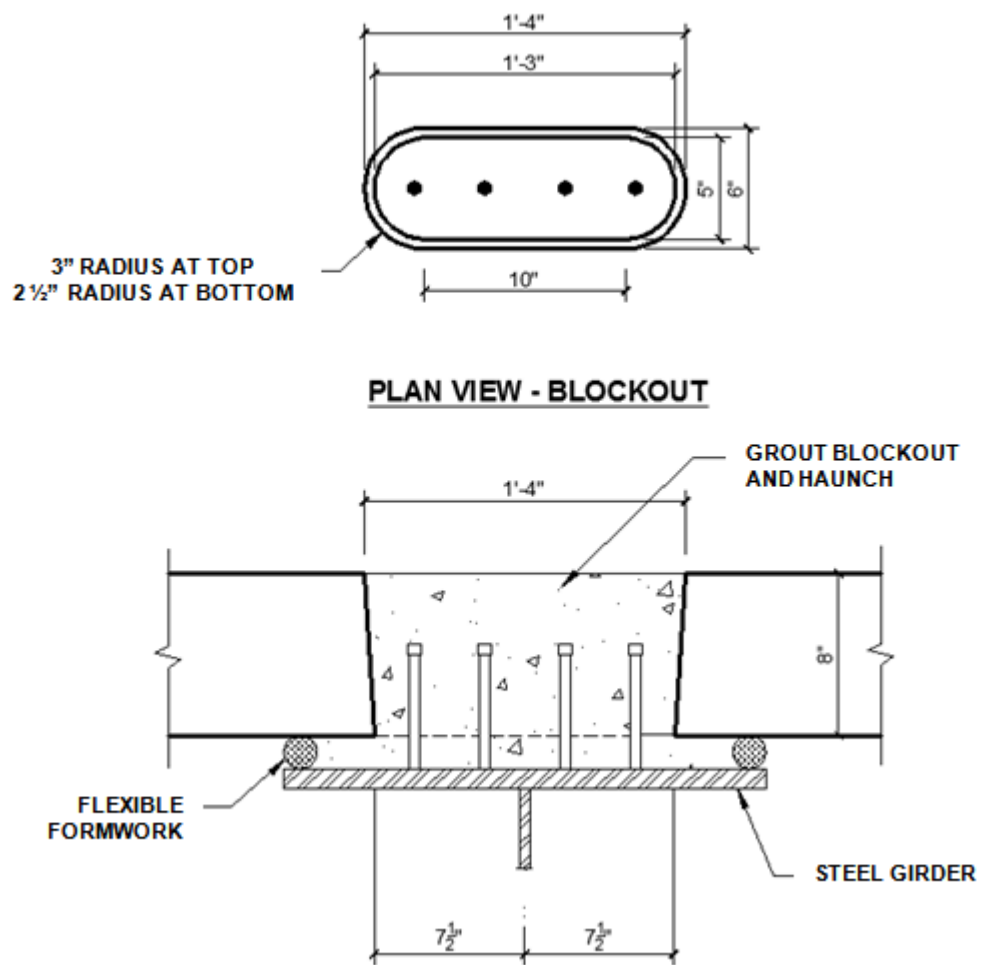

Figure 5-34. Panel to steel girder connection details (Source: Culmo 2009)

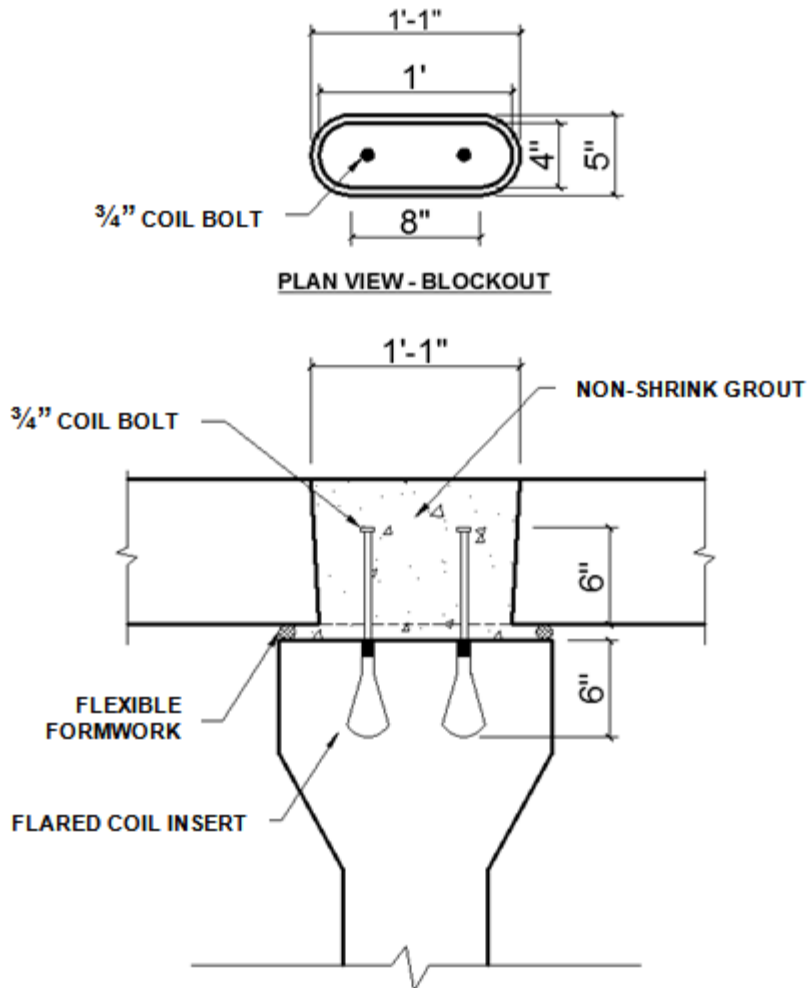

Figure 5-35. Panel to concrete girder connection details

Shim packs have been previously used for supporting and leveling the panels. Ensuring proper support, setting up the deck crown, and constructability are the primary complications associated with using shim packs. Leveling devices are used for supporting full-depth deck panels (Figure 5-36). Leveling devices can also be specified as a temporary support to overcome the difficulties described above. Leveling devices will provide support to panels until haunches are grouted and have achieved sufficient strength to carry the load due to remaining construction activities. Placing deck panels over the girders will be easier with the use of leveling devices. Also, with the use of leveling devices, differential camber can be adjusted. The leveling bolts can be designed to support the deck dead load and other temporary construction loads. Following connection grouting, leveling devices can be removed or may be left embedded in the deck.

Designing leak proof formwork and ensuring fully consolidated grouted connection are reported as difficulties. This is primarily because grout is expected to consolidate only under gravity. One such example is the formwork for grouting the haunch between full-depth deck panels and the girders. In the majority of cases, steel angles, wooden formwork, or flexible foams have been used. Flexible formwork is recommended here because girder and panel surface gap irregularities and panel movement during adjustments are accommodated (PCI NE 2011). The commonly specified flexible foams for grouting the haunches (Figure 5-36) are (1) polypropylene tubing seal, (2) elastomeric tubing, and (3) polyethylene rod.

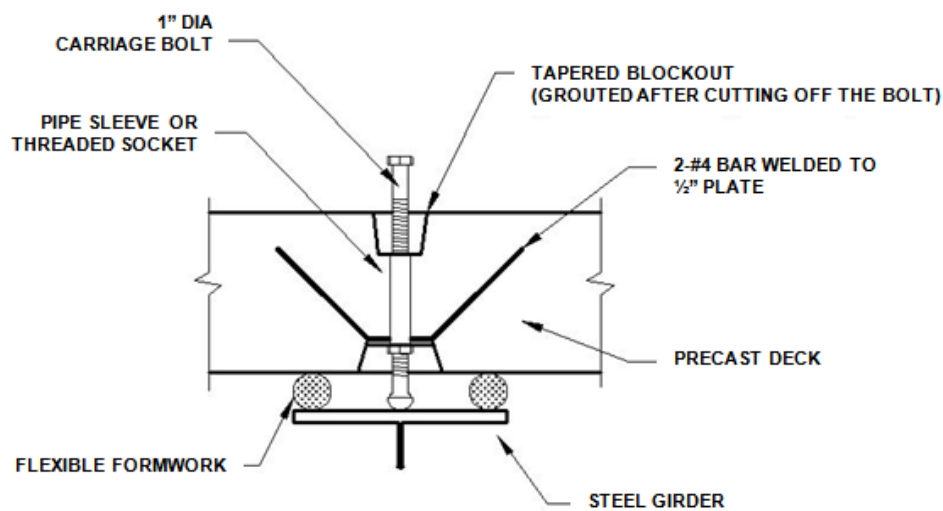

Figure 5-36. Leveling device detail and formwork at the deck level (Source: PCI NE 2011)

5.2.1.4 Continuity Detail over the Pier or a Bent

Continuity detail over the pier or bent can be established using splice sleeves provided at the deck level and continuity reinforcement provided at the bottom flange of the beam (Figure 5-37). The splice sleeves are slid into position after placing a beam over the adjacent span. A similar detail can be used to establish the live load continuity over the piers for steel girders. The connection detail at the bottom flange is shown in Figure 5-38. The complexities reported with this connection are (1) connecting splice sleeves is a tedious and time consuming process, and (2) maintaining beam reinforcement alignment for splice sleeves is difficult.

Another option for continuity over the pier or a bent can be established with link slabs (Figure 5-39). Link slab analysis and design procedures presented in Ulku et al. (2009) are recommended. Link slabs have been implemented in the Mass DOT Fast 14 ABC project.

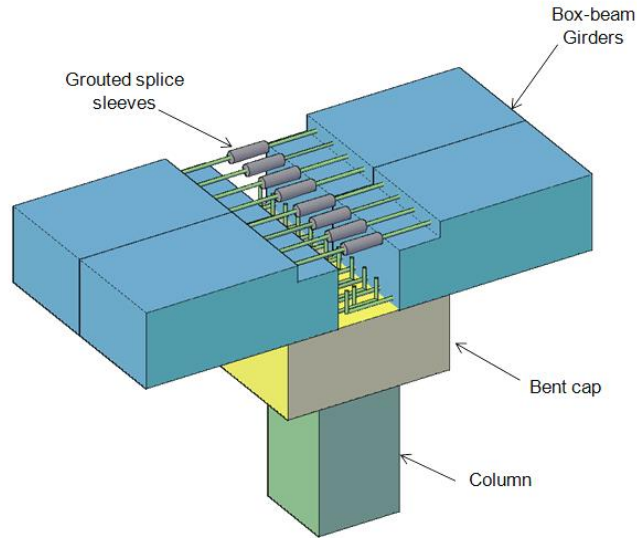

Figure 5-37. Continuity detail at pier using splice sleeves (Source: Culmo 2009)

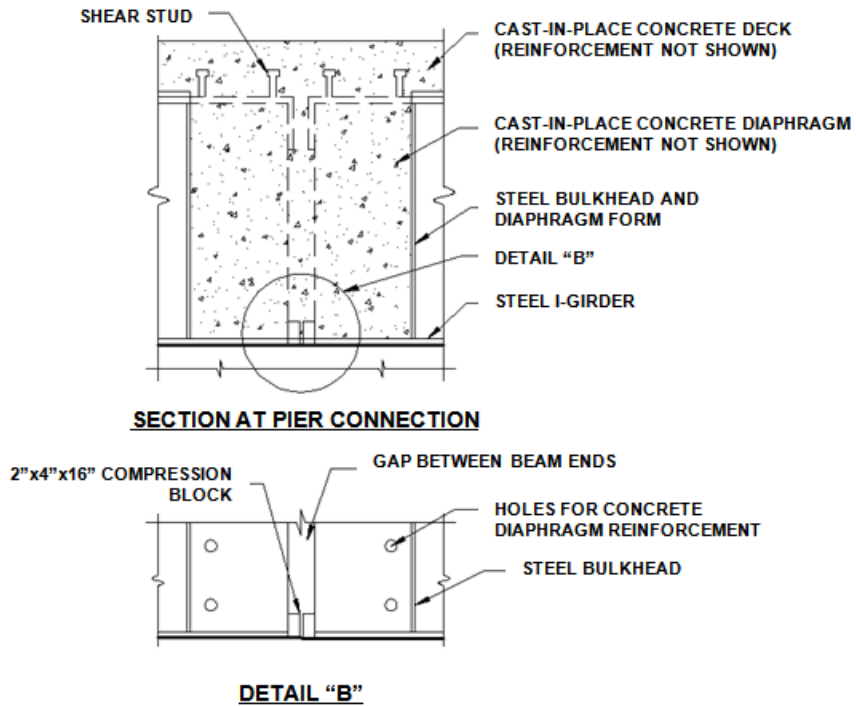
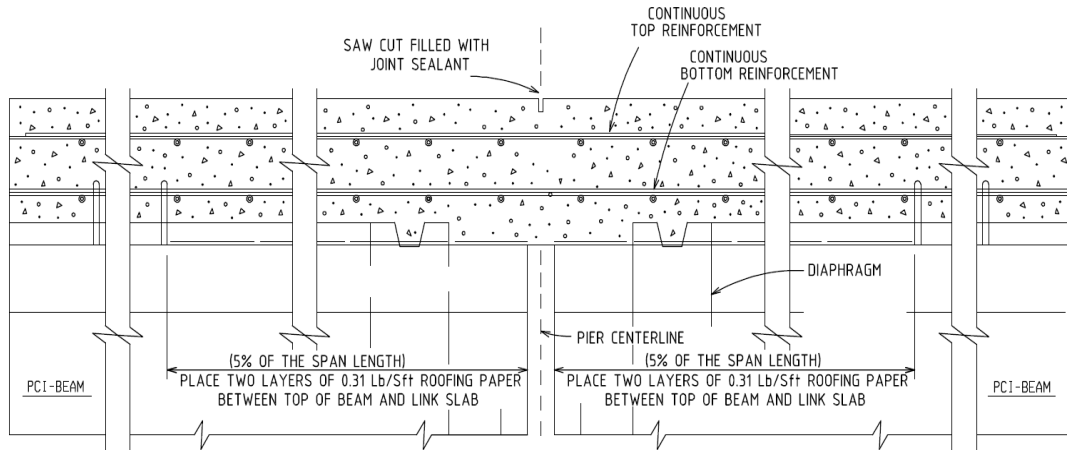
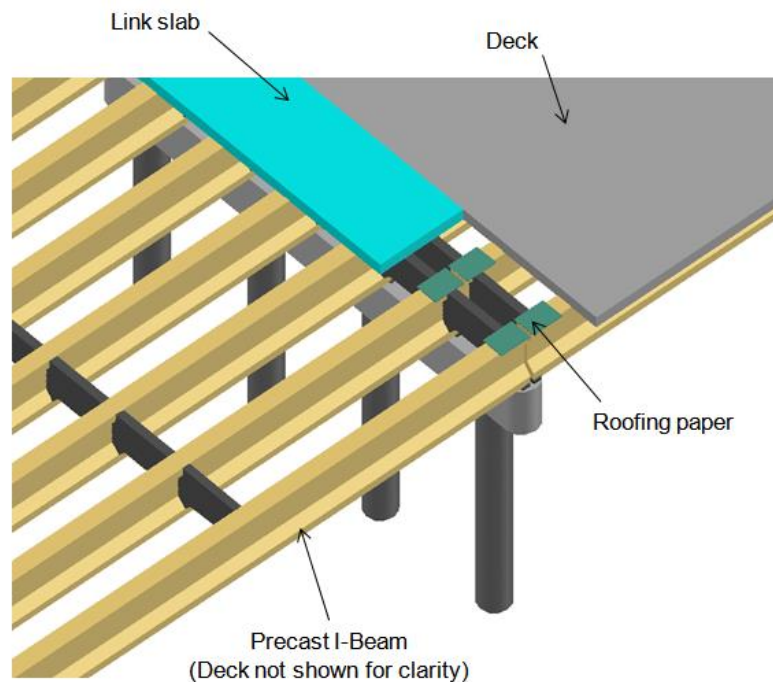

Figure 5-38. Continuity detail at pier of a steel box girder (Source: Culmo 2009)



(a) Cross-section of a link slab



(b) 3-D view of link slab details

Figure 5-39. Continuity detail at pier using link slab (Source: Ulku et al. 2009)

5.2.1.5 Continuity Detail at the Abutment

Semi-integral abutment is recommended for ABC projects based on in-depth assessment of all available details to establish the continuity over the abutment. This connection detail also allows for generous tolerances. The superstructure is isolated from the substructure where repair, rehabilitation and replacement activities will not involve the substructure (Aktan and Attanayake 2011). A precast approach slab and an associated sleeper slab can also be specified

in lieu of cast-in-place concrete construction. The transverse restraint systems for skew bridges with semi-integral abutments were detailed in Aktan and Attanayake (2011).

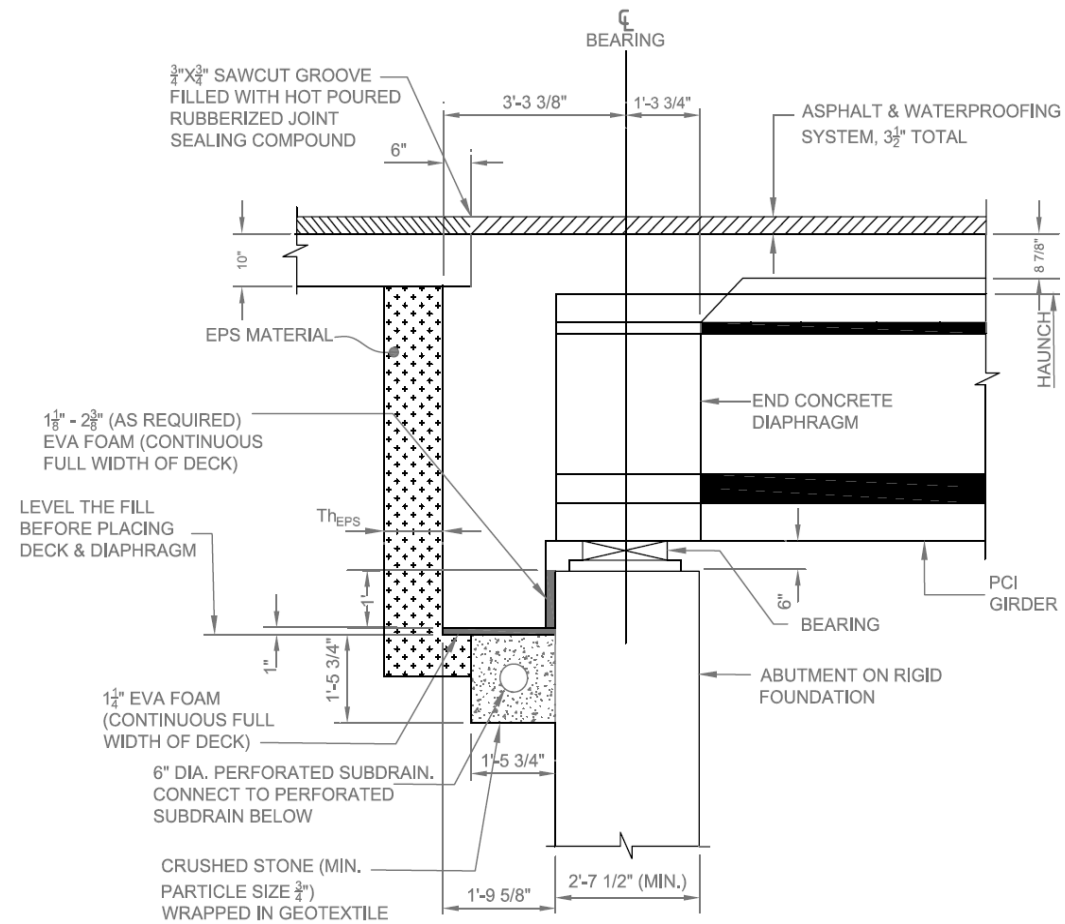

Figure 5-40. Continuity detail at abutment with semi-integral abutment (Source: Aktan and Attanayake 2011)

5.2.2 Recommended Substructure Connection Details

The connections between the substructure elements are primarily established using grouted splice sleeves and/or grouted pockets. The recommended connection details are listed in Table 5-4.

Table 5-4. Recommended Connection Details for Substructure

Substructure connection type	Recommended connection details
Pile cap or abutment stem to pile	Corrugated grouted pocket with grout access hole at the pile cap/abutment stem (Figure 5-42)
Column to footing	a) Grouted splice sleeve with socket at footing (Figure 5-45) b) Void with shear key at the footing for grouted column connection (Figure 5-46)
Abutment wall to footing	Grouted splice sleeve with a channel at footing (Figure 5-48)
Pier or bent cap to pier or column	a) Grouted pocket and two layers of reinforcement (Figure 5-49) b) Grouted duct or splice sleeve (Figure 5-50, Figure 5-51)
Vertical connection between elements	a) Vertical connection between abutment stems b) Vertical connection between bent caps

Segmental columns and piers are often specified for high and long-span bridges. Segmental columns and piers are not commonly specified in bridge construction with unremarkable attributes even though their benefit for accelerated construction is high. The segmental columns or piers are good candidates to overcome transportation limitations or sites not able to accommodate large equipment for placing heavy substructure units. There are no current design details or standard sections of segmental piers and columns for unremarkable bridges. For this reason, they are not included in Table 5-3; however, the details are presented in Section 5.2.2.6.

Most of the substructure connections are established using grouted splice sleeve, blockout, and pockets as presented in Table 5-4. Stringent tolerance requirements for the connection will improve constructability. The use of a template is encouraged for splice sleeves or ducts when casting the precast elements. The splice coupler template can be used while casting both precast elements, which are to be connected. A similar approach can be used even when a

precast element is connected to a cast-in-place concrete component. The construction sequence of using templates for a splice sleeve connection is shown in Figure 5-41.

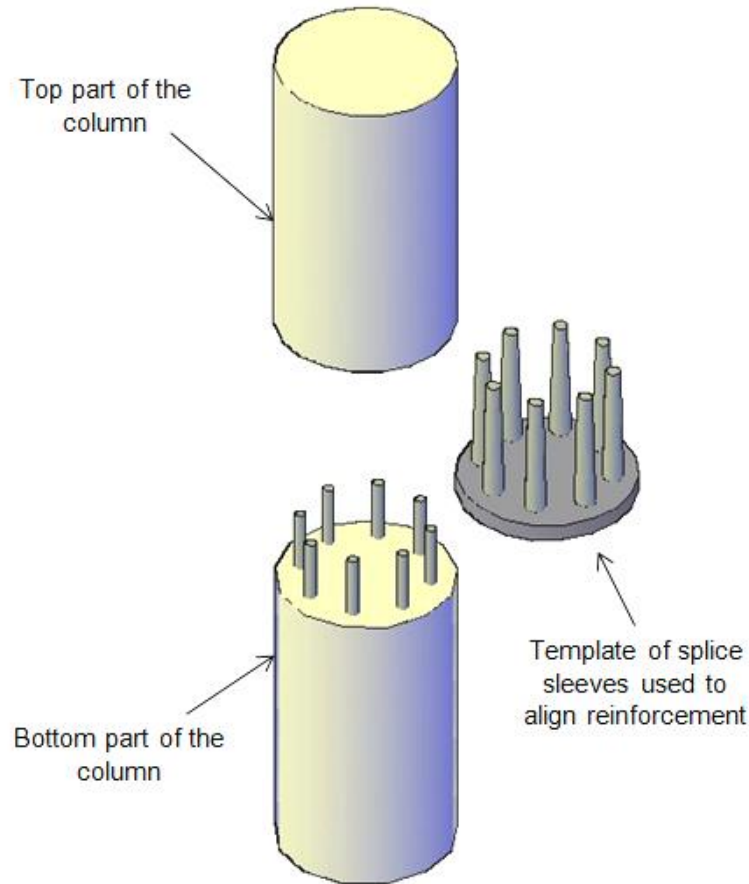

Figure 5-41. The template used for a column splice with grouted splice coupler

5.2.2.1 Pile Cap or Abutment Stem to Pile Connection

The connection between the pile and precast abutment stem is shown in Figure 5-42. The abutment stem includes a corrugated grouted pocket. The original abutment stem grout pocket detail presented in Culmo (2009) is modified here to an inverted frustum shape. The modification is for preventing grout spall when the grout is cracked or the bond fails due to shrinkage. The cavity in the abutment stem can be formed with and without the corrugated metal casing. However, the use of corrugated metal casing is helpful in fabricating as well strengthening the concrete component.

For a pier cap or abutment stem located high above the ground, a temporary platform (Figure 5-43), or a friction collar (Figure 5-44), is required in order to maintain the space between the top of the pile and the cavity. Use of a temporary support system, if adequately designed, also allows the construction process to continue because the temporary supports will provide a load path before grouting the connections. The access at the top of the precast element is useful for grouting. Grouting can be placed by gravity flow with the use of a funnel and tremie tube, which can be inserted into the bottom of the pocket. The pocket can be grouted effectively and without entrapping air, by starting the grouting process from the bottom of the cavity. Non-shrink grout needs to be specified in order to avoid cracking and bond failure under shrinkage. Similar connection details can be used between bent cap and the columns and the pier cap and the pier.

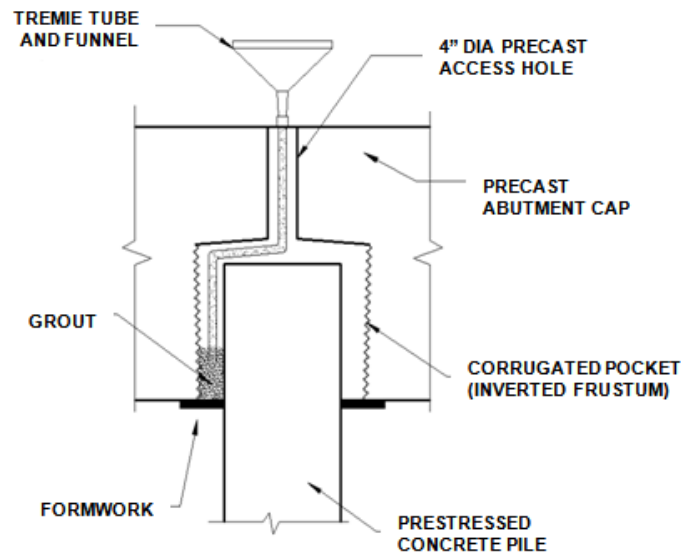

Figure 5-42. Precast concrete abutment cap to prestressed concrete pile connection



Figure 5-43. Temporary support system for pile cap to pile connection (Source: Wipf et al. 2009a)

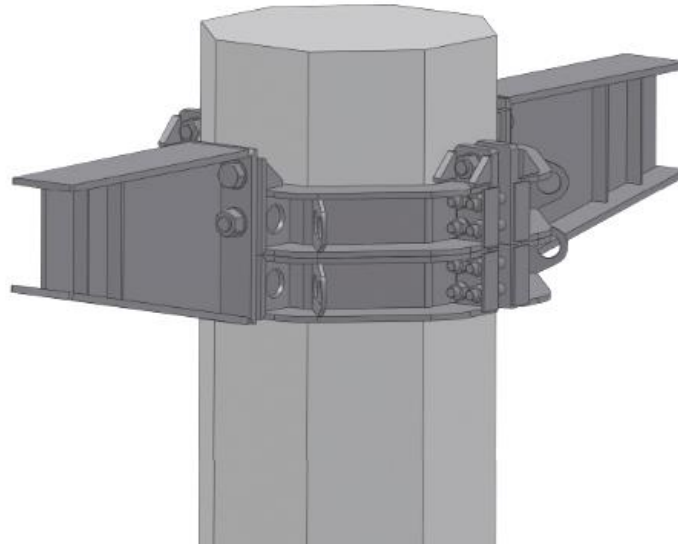

Figure 5-44. Adjustable friction collar fixed to the octagonal column to temporarily support abutment cap or pier cap (Source: www.proscaffna.com)

5.2.2.2 *Column to Footing Connection*

The connection details recommended between a precast concrete column and footing are

1. Grouted splice sleeve with socket at the footing (Figure 5-45), and
2. Cavity or pocket with a shear key (Figure 5-46).

Use of a template is recommended for the grouted duct or splice sleeve type connections while casting the precast elements. The template will allow stringent tolerances for enhanced constructability. For the socket, shims can be used to place and level the column. High early strength, non-shrink type grout needs to be specified for the splice sleeve. Providing a socket

at the footing helps form the grout bed. Also, bridge plans should include the type of sleeve and access to the grout inlet valve in addition to the socket depth and width dimensions. The recommended grouted splice sleeve connection is shown in Figure 5-45.

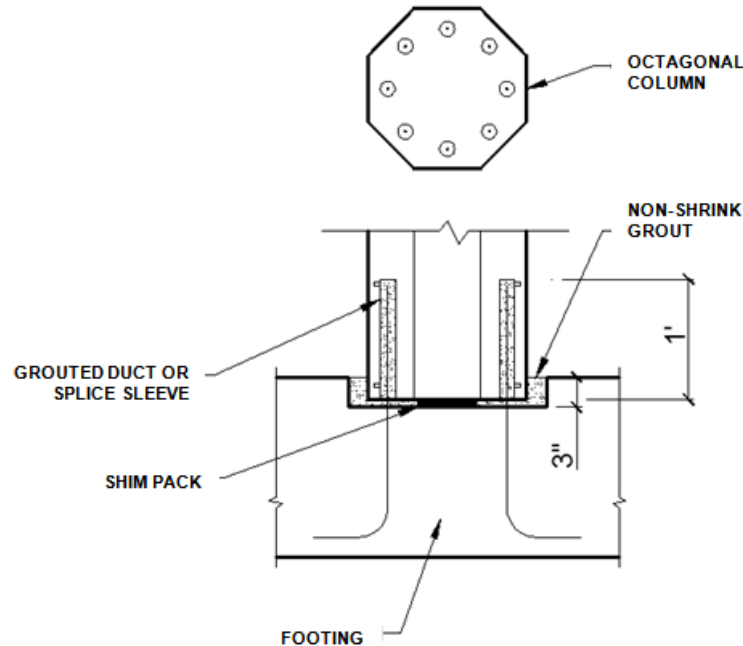

Figure 5-45. Octagonal precast column to footing connection with grouted duct or splice sleeve and socket connection

A precast concrete column to footing connection is shown in Figure 5-46. The connection cavity can be designed to be smaller than the column cross section. This way the column can rest on top of the footing without transferring the load to the reinforced connection. In this case, the column is not embedded into the footing, hence the reinforcement is embedded into the joint to transfer moment and shear. The bearing area of the column can be designed to support the loads until the grouted void achieves the required strength. If the connection cavity volume is large for neat grout, extended grouts or high early strength concrete can be used. If extended grout and concrete is specified, adequate space needs to be provided to place and consolidate the material. An example of such a connection is shown in Figure 5-47, where the connection cavity corners are beveled to provide adequate space for material placement and consolidation. The detail shown in Figure 5-47 includes threaded bars; however, column reinforcement can be extended where practical. A steel plate is attached to the bottom of the connection cavity to retain the grout within the footing.

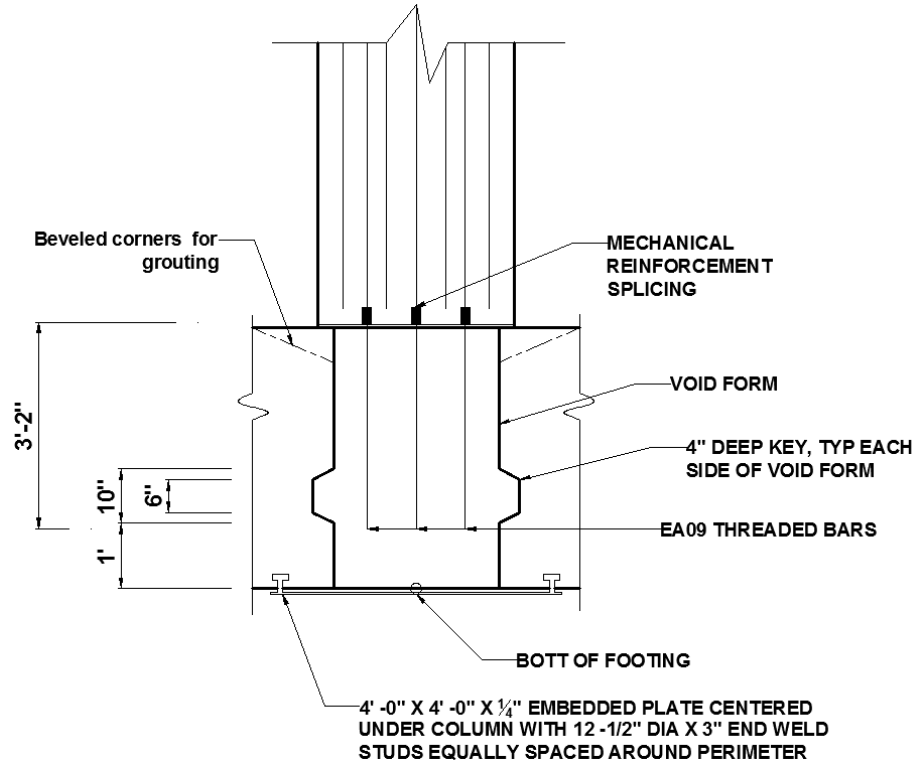

Figure 5-46. Circular precast column to footing connection with grouted void/pocket and shear key



Figure 5-47. Column to footing connection with beveled void corners (Source: Photo courtesy of MDOT)

5.2.2.3 Abutment Wall to Footing

A grouted splice-sleeve is an efficient way to allow for moment and shear transfer between a footing and abutment wall. The connection can be made by providing a socket on the footing for placing the abutment. The socket also helps to contain the grout. Shim packs can be used to align and level the abutment as shown in Figure 5-48.

The size of the socket needs to be designed based on the space requirement for grouting the splice sleeves and to have sufficient access to the splice sleeve grout inlet for grouting. Joint waterproofing material can be used for reinforcement protection (Figure 5-48). To avoid any conflict, the splice sleeves and the extended bars from the footing need to be aligned. As discussed in Section 5.2.2, while casting the elements, requiring the use of a template of the splice sleeves is recommended (Figure 5-41).

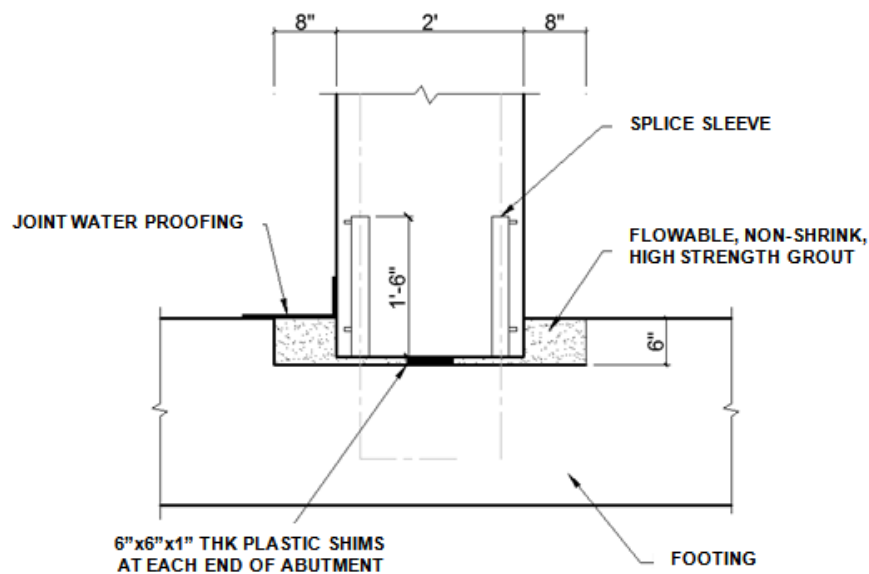

Figure 5-48. Precast concrete abutment to precast concrete footing

5.2.2.4 Pier Cap or Bent Cap to Pier or Column Connection

The connection detail recommended in the NCHRP-681 project is shown in Figure 5-49 (Restrepo et al. 2011). There are two grout pockets with two reinforcement layers. The bent cap is shimmed, and the connection cavity is filled with extended non-shrink grout or high early strength concrete through the opening at the top of the bent cap. This way construction can continue without any interruptions. Connection reinforcement may be (1) bars extending

from the column, (2) bars threaded into the column, or (3) bars that are inserted into the column through drilled holes or corrugated ducts that are grouted.

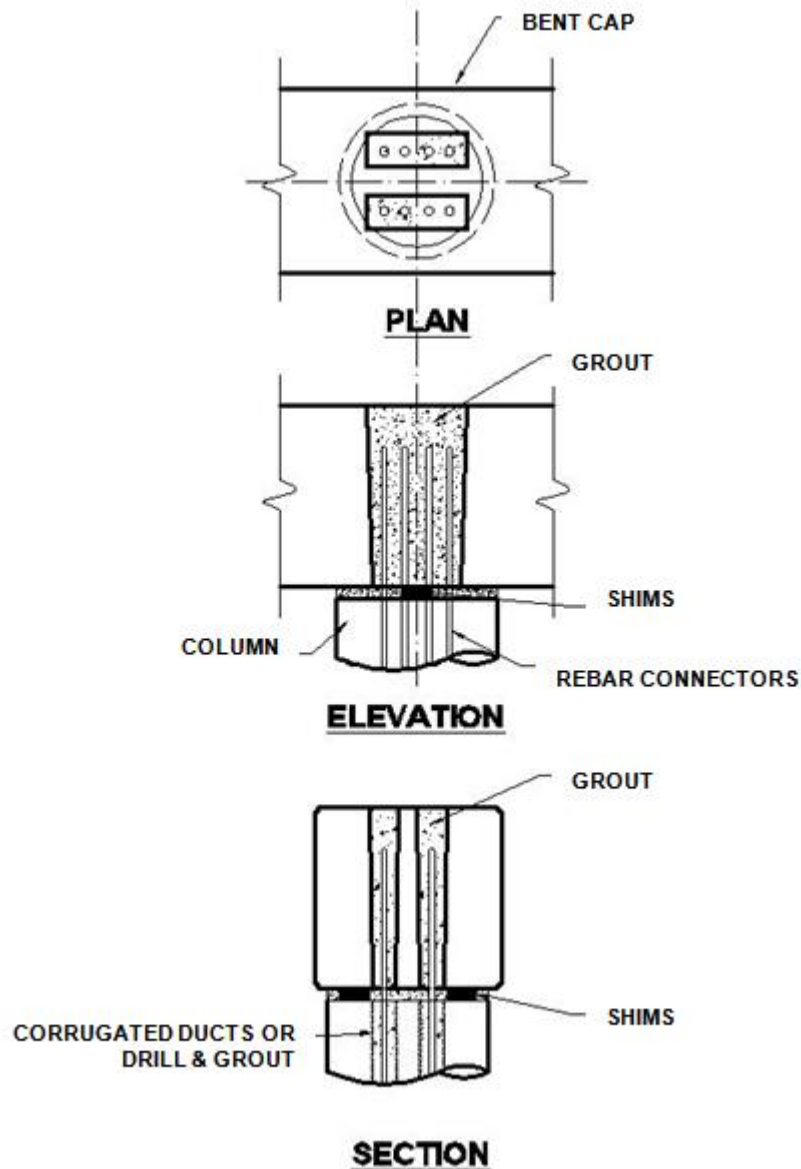

Figure 5-49. Precast bent cap to precast column connection details with grouted pocket and two layers of reinforcement (Source: Restrepo et al. 2011)

The connection between the columns and bent cap, shown in Figure 5-50, includes corrugated ducts to connect the reinforcement extending from the columns. Establishing the connection between the columns and the bent cap is challenging as it requires aligning a group of bars that are extended from multiple columns. However, this detail has been successfully implemented with the prefabricated units. The alignment difficulties can be reduced by using a template

while casting the columns and bent cap. Use of a template will also help control more stringent tolerances which will enhance the constructability. The ducts are often pressure grouted, and the tubes are cut off. Proper vent tubes or outlet tubes should be specified to ensure an air-pocket free connection. Implementing the detail shown below (Figure 5-50) will require a pause in construction activities until grout develops the required strength. If the project schedule will not allow the pause, an adjustable friction collar (Figure 5-44) can be installed which allows load transfer directly from the bent cap to the columns. Another option is the vertical splice duct connection, as shown in Figure 5-51, that includes a capital on each column. The column capital can be designed to provide sufficient bearing area for safe transfer of loads to the pier.

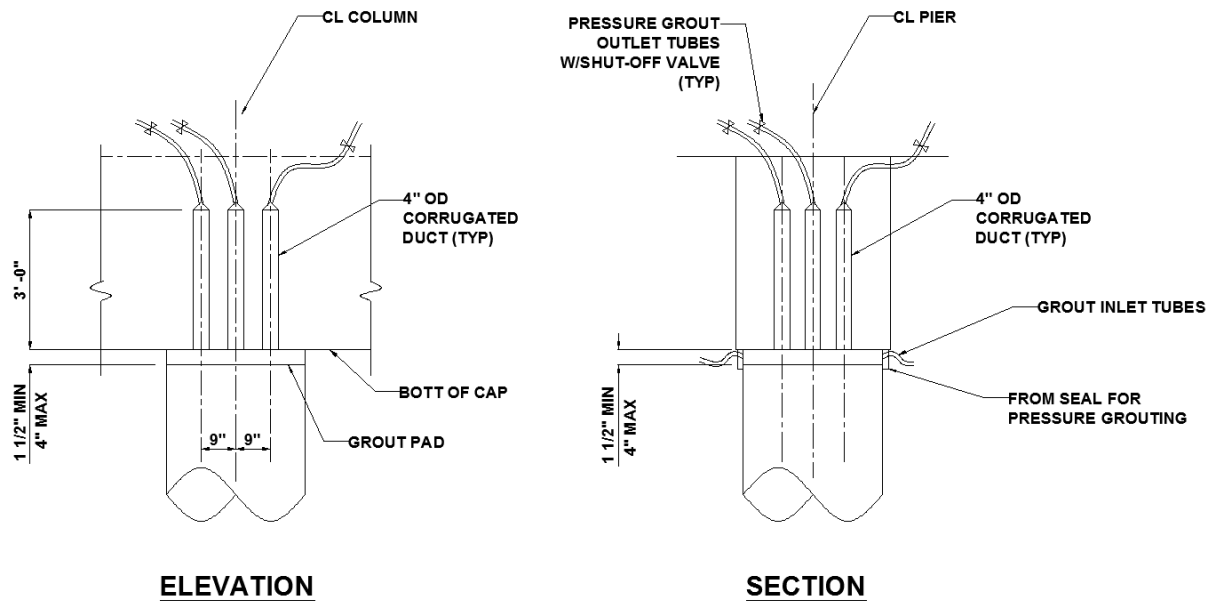
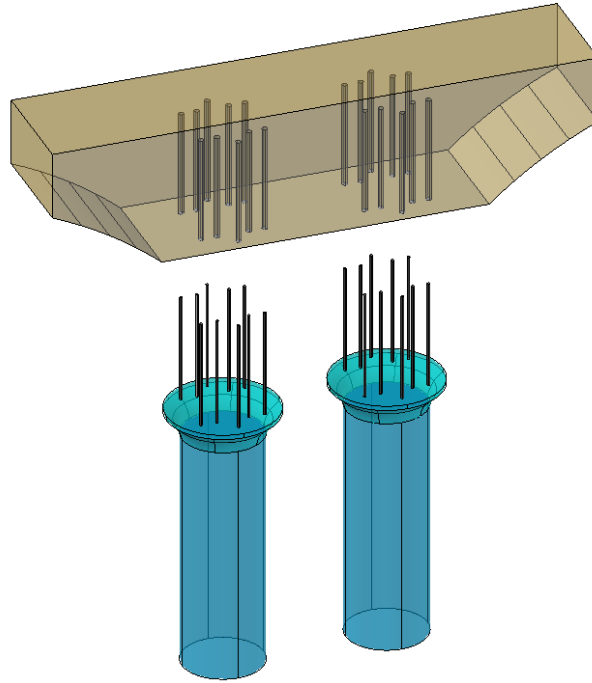
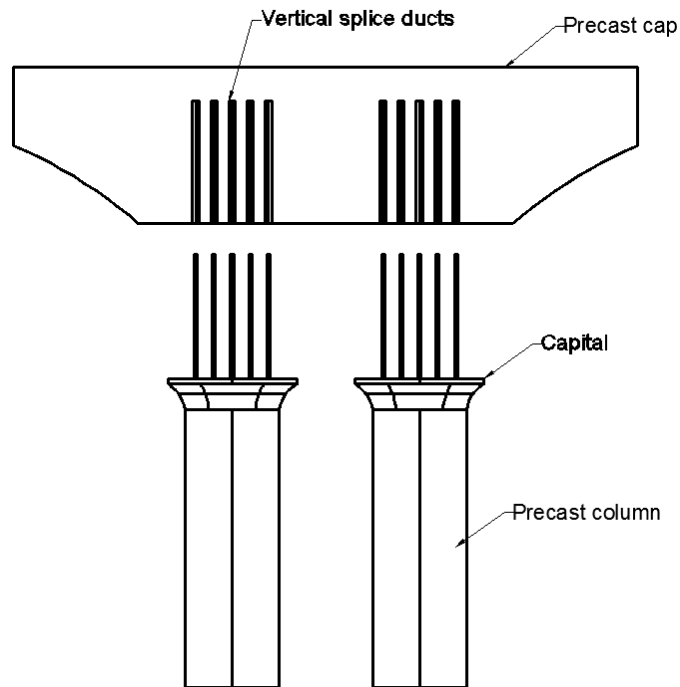

Figure 5-50. Grouted corrugated duct connection for precast bent cap to precast concrete column



(a) 3D-view of the bent cap to column connection detail



(b) 2D-view of the bent cap to column connection detail

Figure 5-51. Vertical splice duct connection for precast bent cap to precast concrete columns (Source: Culmo 2009)

5.2.2.5 Vertical Connection between Elements

A vertical connection between substructure elements or splicing is commonly used to control the size and weight of substructure units such as abutment stems and bent caps. Splicing is performed with grouted shear keys or reinforced concrete connections that transfer both moment and shear (Figure 5-52, Figure 5-53 and Figure 5-54). A moment and shear transfer connection between substructure units is recommended considering Michigan exposure that develops large thermal cycles. The moment and shear will be generated by the back wall sliding over the abutment under thermal cycles. Recommended details are presented in Figure 5-52, Figure 5-53, and Figure 5-54. The difficulty of the reinforced connections is the conflict between reinforcement during installation by lowering the abutment. In some of the recently completed projects, splice reinforcement needed to be bent in the field to correct for this conflict.

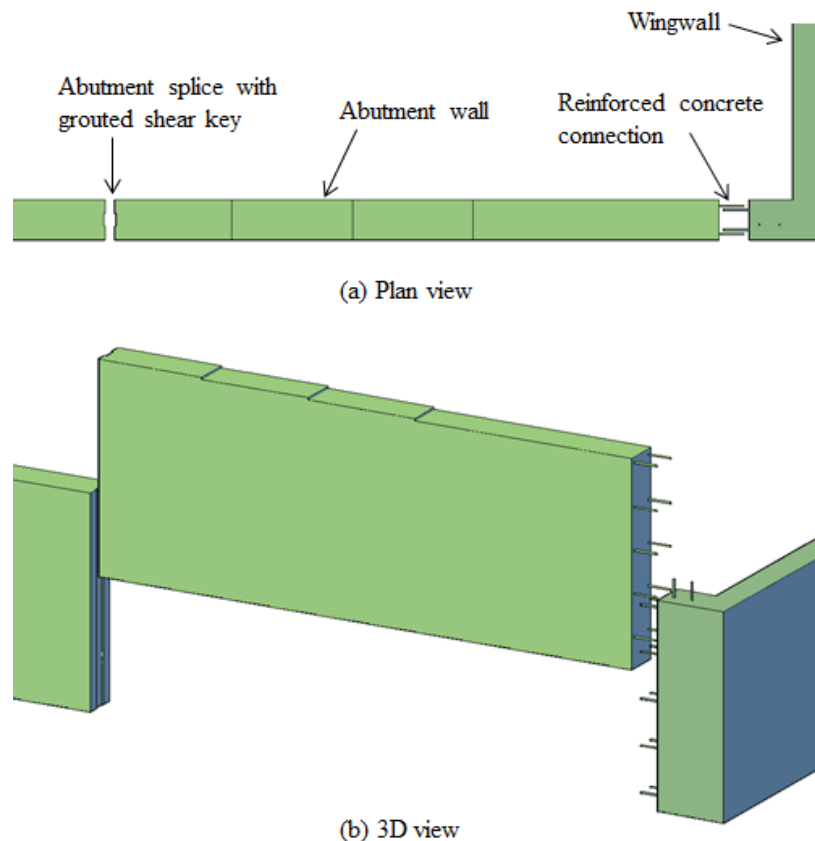

Figure 5-52. Grouted shear key and reinforced concrete connection details

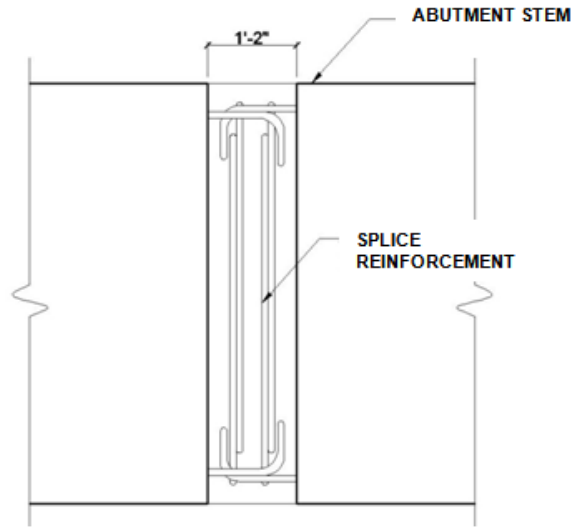

Figure 5-53. Abutment stem splice connection details

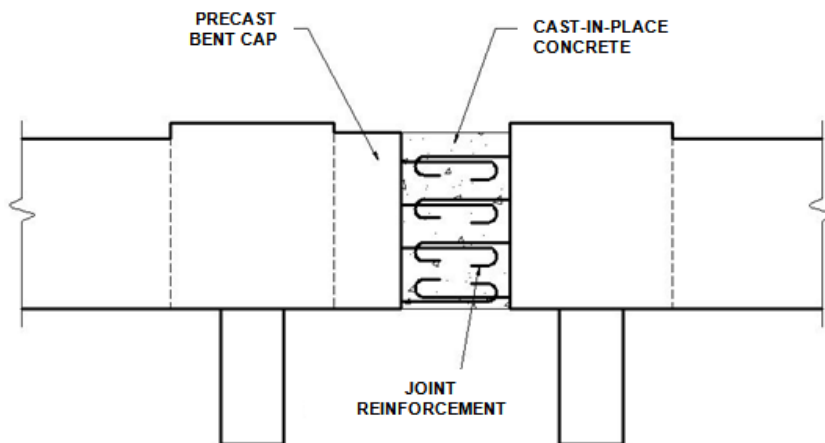

Figure 5-54. Bent cap connection details

5.2.2.6 Connection between Segmental Columns or Piers

Splicing is needed for columns and piers to control the weight of an individual element when used in large or tall bridges. A column splice detail is shown in Figure 5-55 designed for moment, shear, compression, torsion, and tension transfer. One of the difficulties with this detail is maintaining the alignment of splice bars and couplers. This can be overcome by using templates during precasting, as discussed in Section 5.2.2.

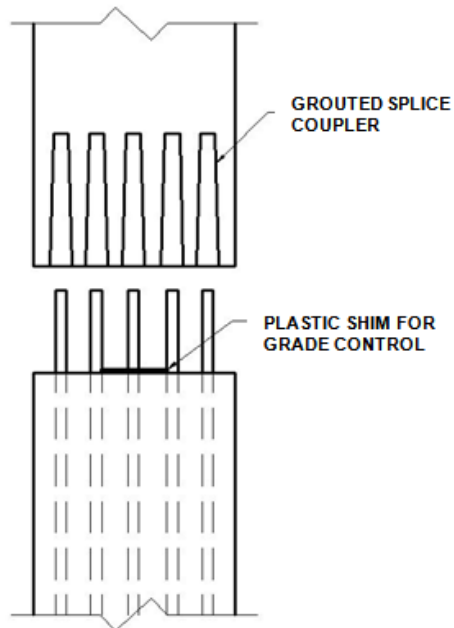

Figure 5-55. Column splice with grouted splice coupler (Source: Culmo 2009)

Another option for vertical connection between precast elements is to use vertical post-tensioning as shown in Figure 5-56. The connections are established using epoxy grouted shear keys and post-tensioning that runs throughout the length of column. Bars are used to connect and align each segment for stability during construction until the post-tensioning is applied to compress the entire assemblage. The difficulty with this connection detail is to maintain tolerances for an uneven fit at the match-cast connection. Another difficulty is to maintain the post-tensioning duct alignment. Strict quality control measures can help with the constructability challenges.

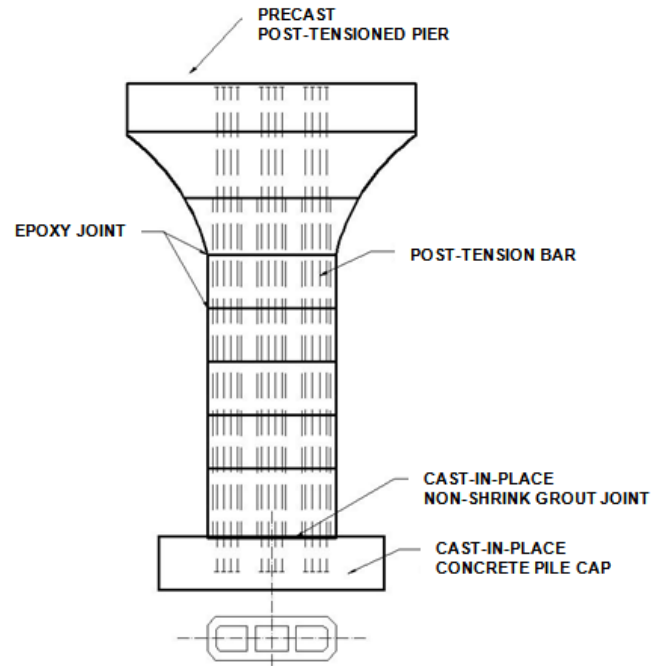

Figure 5-56. Vertical connection of precast pier element (Source: Culmo 2009)

5.3 GROUT MATERIALS

5.3.1 A Grout Selection Example

To demonstrate the recommended grout selection process discussed in the literature review, a typical column to footing connection detail is selected. The details of the connection are shown in Figure 5-57, Figure 5-58, and Figure 5-59. The site and schedule constraints and geometric dimensions of the grout void are listed below.

- The grout is exposed to freeze/thaw considering Michigan exposure.
- The compressive strength requirement is 3.0 ksi to be achieved within 24 hours as per the construction schedule.
- The working temperature range is 45 °F - 85 °F.
- The maximum grout working time requirement is 45 min.
- The grout void dimension is 30 in. × 30 in. × 42 in.

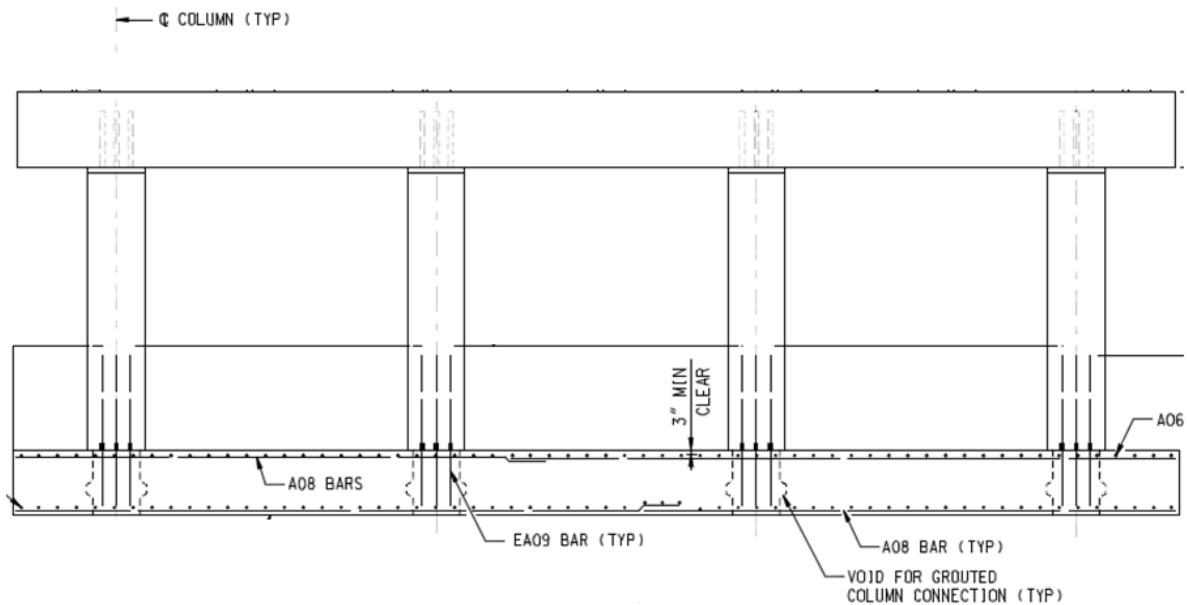

Figure 5-57. Elevation of the pier

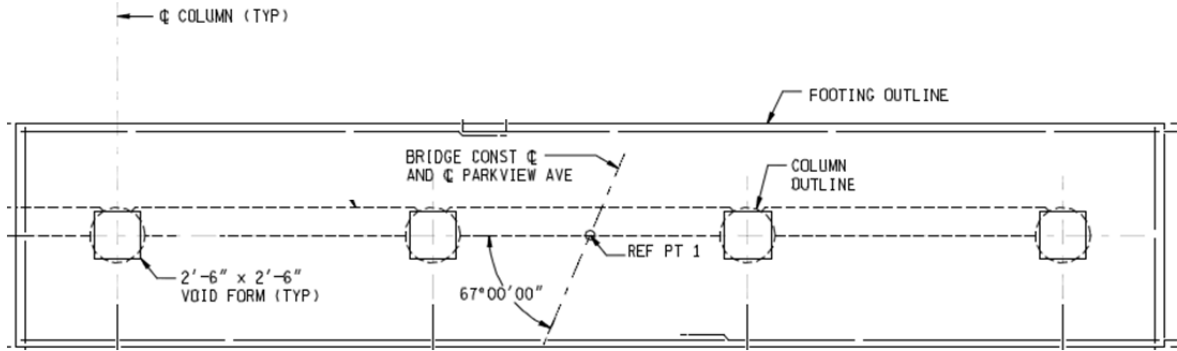

Figure 5-58. Plan view of the footing

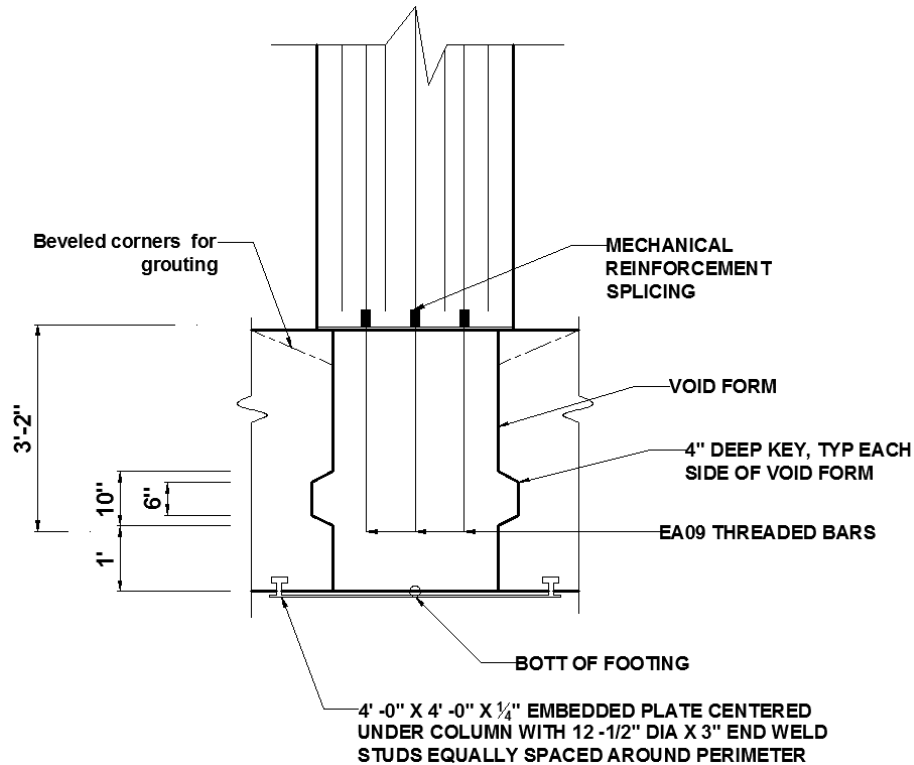

Figure 5-59. Column to footing connection

The grouts listed in Section 2.4 of this report are considered for this application. Suitable grouts that fulfill the freeze/thaw exposure requirement are listed in Table 5-5. However, SonogROUT 10k cannot fulfill the compressive strength requirement of 3.0 ksi in 24 hours and is eliminated for further consideration. SikaGrout 212 is eliminated because it cannot fulfill the working temperature range requirement. The working time requirement can only be fulfilled using *Set 45 HW*, *EUCO SPEED MP*, and *S Grout*. The *Set 45 HW* and *EUCO SPEED MP* are magnesium phosphate grouts, which generate significant heat during the hydration

process. The size of the connection cavity is not suitable for grouts with high heat generation. Following these considerations, only *S Grout* remains suitable for this application.

None of the identified grouts are suitable for placement in neat form due to the large cavity volume. The S Grout can be extended using sand. However, the strength of extended grout will be lower than documented in the table for neat grouts; yet water reducing admixture can be specified to allow the grout to achieve high strength. With these modifications, it is necessary to evaluate the rate of strength development, as well as the setting time, shrinkage, and freeze/thaw resistance. Mock-up tests are needed to evaluate these properties. Finally, following the grout selection, provisions need to elaborate on connection cavity surface preparation as per the manufacturer’s recommendations.

Table 5-5. Recommended Grouts for the Given Project Requirements

		Set 45 HW	EUCO SPEED MP	Masterflow 928	S Grout	SonogROUT 10k	SikaGrout 212	PRO GROUT 90	Project Requirement
Compressive strength (ksi) (min. 5.0 ksi at 24 hrs. as per AASHTO 2010)	1 day	6.0	6.0	4.0	3.5	1.6	3.5	4.7	3.0
	3 days	7.0	6.5	5.0	5.0	3.8	-	5.6	
	7 days	-	7.0	6.7	6.0	5.1	5.7	6.6	
	28 days	8.5	7.5	8.0	8.0	6.2	6.2	7.8	
Initial setting time (min)		15	12	3 hrs	45	3 hrs	5 hrs	4 hrs	45
Filling depth/thickness for neat grout (in.)	Min	0.5	0.5	1	-	0.5	0.5	-	
	Max	2	1	6	2	2	2	-	
Working temperature (°F)	Min	-	-	45	40	65	45	-	45
	Max	100	85	90	85	75	70	-	85
Freeze/thaw resistant		YES	YES	YES	YES	YES	YES	YES	YES
Extend with aggregate		YES	YES	YES	YES	YES	YES	-	YES

5.3.2 Recommendation for Grout Selection

Proprietary and non-proprietary grouts and mixes can be specified for precast element connections. The properties of proprietary grout are documented in Chapter 2 of this report and evaluated for their usage and limitations. Proprietary grouts develop high early strength and can possess non-shrink properties. A list of non-proprietary concrete mixes available in literature is also presented in Chapter 2 of this report. Non-proprietary mixes such as high

performance concrete (HPC) and ultra-high performance concrete (UHPC) have slow strength development process compared to the proprietary grouts. Hence, non-proprietary mixes may not be suitable for strict project duration limitations.

The recommendations for grout selection are as follows:

1. A project designer needs to be equipped with all available grout/mortar types, properties, application procedures, and limitations.
2. Connection detail design needs to be finalized following the review of material properties, application procedures, and limitations.
3. Special provisions may include requirements for mock-up testing if the specific grout/mortar identified for the project will be used with modifications and the property data is not available.

5.4 DECONSTRUCTION METHODS AND EQUIPMENTS

The prefabricated bridge elements and systems recommended for Michigan are presented in Section 5.1 of this report. Except the spliced girder systems and full-depth deck panel systems, the remaining prefabricated components or systems are assembled onsite as simple spans and then converted to continuous spans for live loads. Even when the bridge superstructures are placed using SPMT or slide-in techniques, simple spans are used except in a few projects such as the Sam White Bridge in Utah. In the case of full-depth deck panel systems, the girders are designed as simple spans to carry the dead load of the girder and the deck panels.

The deconstruction process will primarily involve removing continuity details between panels as well as the girder ends following the reverse order of construction to make the spans simply supported. The deconstruction procedures can follow the reverse order of construction for PBES without compromising safety. Only the spliced girder bridges require using temporary supports or counter weights if the reverse order of construction is followed for deconstruction.

In all cases, the deconstruction process requires detailed assessment of the bridge superstructure and substructure condition and structural analysis to evaluate the stability of the structure before planning and scheduling deconstruction activities. Bridge scour and/or substructure deterioration can lead to instability issues and may require temporary supports. Therefore, it is essential to assess the existing post-tensioned ducts (if applicable) prior to deconstruction of bridges. A structurally sound grouted post-tension system may be assumed to be fully bonded so that a sudden release of post-tension forces may not cause instability or hazardous conditions (Lwin 2003).

Under the ABC concept, the deconstruction of the bridge starts after scheduling the construction activities. By that time, the project team is knowledgeable of the equipment and the construction technology that is planned. This is also an opportunity for the project team to utilize most of the equipment already deployed at the site to be used for deconstruction activities. This is further discussed later in the chapter under deconstruction techniques.

Carefully planned and executed deconstruction could contribute to sustainability. When the deconstruction is performed following the reverse order of construction, and the components are in good condition following removal, there is a possibility of reuse.

5.4.1 Deconstruction Techniques

A deconstruction technique should be selected considering the parameters listed in Section 2.5 of this report. Location and accessibility, shape and size of the structure, time constraints, and maintenance of traffic (MOT) are some of the important parameters. An in-depth analysis of those parameters for a particular site and bridge configuration needs to be carried out to develop an efficient deconstruction process. Several deconstruction techniques are discussed in Section 2.5 of this report. The PBES recommended in Section 5.1 are suitable for short and short-to-medium span bridges; hence, the most appropriate techniques for deconstruction are the following:

- Removing the superstructure or the entire structure using Self-Propelled Modular Transporters (SPMTs),
- Removing the superstructure using horizontal skidding or the slide-out technique,
- Removing individual components, modules, or systems in the reverse order of construction, and
- Using traditional bridge demolition techniques when none of the above techniques are feasible due to site conditions and accessibility, bridge structural configuration or condition, maintenance of traffic (MOT), schedule, availability of equipment, or a combination thereof.

The above listed bridge deconstruction techniques need to be augmented by several other operations, which are these:

- Drilling, sawing, and cutting,
- Hydrodemolition, and
- Demolition by hydraulic attachments (hammer, shear or pulverizer etc.).

The use of SPMTs, the skidding technique, or the removal of individual components/modules/systems during deconstruction requires the spans to be simply supported. Semi-integral abutments greatly simplify the deconstruction process. Further, they help to remove the superstructure without any damage to the abutment. However, if isolating the components/modules/systems is required, hydrodemolition, hammering, concrete saw cutting, metal cutting techniques or a combination thereof can be used. Details such as reinforced

concrete diaphragms and link slabs are used over the piers or bents to establish the live load continuity between spans. The use of link slabs helps in the deconstruction process while converting spans to simply supported.

Use of a regular concrete saw that can cut up to 12 in. is adequate. However, a reinforced concrete cast-in-place diaphragm is often deeper than 12 in. and requires hydrodemolition, hammering, concrete saw cutting, metal cutting techniques or a combination thereof to make spans simply supported or to isolate the components to facilitate the removal process.

The continuity between individual components/modules/systems is established using grouts, cast-in-place concrete (special mixes), post-tensioning or a combination thereof in conjunction with unreinforced or reinforced connection details. Saw cutting helps in isolating the individual components/modules/systems to facilitate the deconstruction. A few examples of saw cutting are shown in Figure 5-60 to demonstrate the capabilities and state-of-the-art practices.

Figure 5-61 shows partial and full removal of bridge deck using the hydrodemolition technique. Hydrodemolition can be used to remove small patches of concrete for repair or rehabilitation activities (Calabrese 2000). During replacement of full-depth deck panels, hydrodemolition is a better option for removal of grout or concrete at the blockouts without damaging the girders and shear studs. Hydrodemolition should follow technical guidelines related to wastewater control and debris removal for a better deconstruction process (Winkler 2005). In addition to these methods, the use of a hammer and a pulverizer for bridge demolition is shown in Figure 5-62.



(a) Saw cutting of a bridge deck
(Source: <http://www.476blueroute.com>)

(b) A saw cut section of a segmental bridge
(Source: Lwin 2003)

Figure 5-60. Saw cutting technique



(a) Concrete removal by hydrodemolition
(Source: <http://nationalhydroinc.com>)



(b) Hydrodemolition of a bridge deck
(Source: <http://www.blasters.net>)

Figure 5-61. Hydrodemolition technique

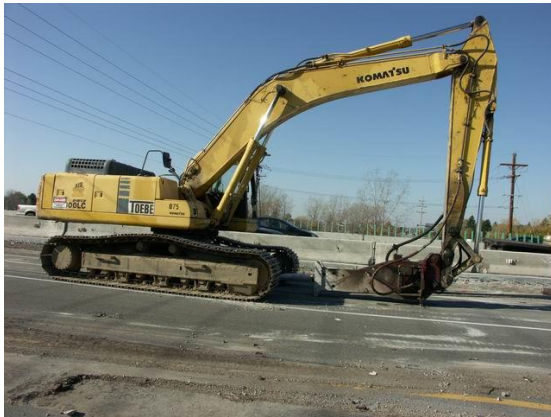

(a) Hammer



(b) Pulverizer in action

Figure 5-62. Demolition by hammer and pulverizer

5.4.1.1 Self-Propelled Modular Transporters (SPMTs)

This technique has been successfully used for bridge superstructure removal and replacement. The use of the technology is limited due to the initial cost and site constraints such as accessibility, space requirement, and utilities (FHWA 2007). Use of SPMTs for bridge deconstruction is justified when the same equipment is used for replacement. When using an SPMT for the deconstruction of deteriorated bridges, the bridges should be carefully analyzed

for structural integrity, structural vibrations and stability, especially in establishing the SPMT support locations. As discussed above, the superstructure continuity details need to be removed for effective use of this technique.

5.4.1.2 Horizontal Skidding

This technique has been successfully used for bridge replacement. The structure can be slid out and then either demolished or deconstructed afterwards. At the same time, the new bridge can be slid into the position. Deteriorated bridges need to be carefully analyzed for structural integrity and stability by considering the temporary support locations. This is a cost-effective method only if the new bridge is replaced using the same technique. The use of this technique is mainly governed by the site condition, including space availability for accommodating both the replacement bridge and the old bridge. Further, the significance of the feature intersected is a major parameter because the removed bridge superstructure has to be demolished or deconstructed while the spans are over the feature intersected.

5.4.1.3 Removing Individual Components, Modules, or Systems in the Reverse Order of Construction

Deconstruction of bridges by removing individual components, modules, or systems, requires the spans to be simply supported. The deconstruction process can be planned by studying the construction process, as-built details, and condition of the bridge. A thorough assessment needs to be performed considering the existing condition before saw cutting the connections to assure the safety of the structure. As discussed earlier, use of semi-integral abutments and link slabs greatly simplifies the deconstruction process. Isolating individual elements by cutting through field cast connections can be accomplished using concrete saws.

An example of removing a box-beam is shown in Figure 5-63. This method allows using traditional equipment to perform deconstruction operations by adhering to site constraints such as removing debris and controlling dust. In general, the lifting devices need to be attached close to the component supports of the existing bridge. The components can be taken away from the site and be reused or demolished later on. Another advantage of this method is that the equipment deployed in the deconstruction procedure can also help with the construction.



Figure 5-63. Removal of a box-beam

5.4.2 Deconstruction of the Recommended Bridge Systems

Based on the bridge superstructure configuration, the recommended bridge structural systems are categorized into three major groups. The deconstruction steps are broadly divided into superstructure and substructure removal as shown in Figure 5-64. Only the full-depth deck panel system requires three major steps in the deconstruction process. The removal of safety barriers is not explicitly discussed even though it should be the first step of the demolition process as shown in Figure 5-65.

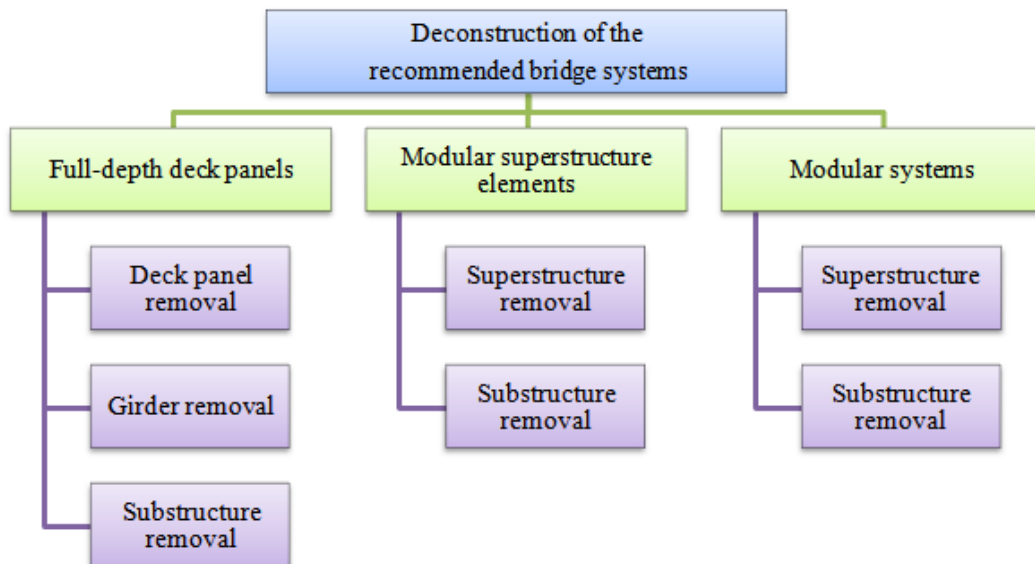

Figure 5-64. Deconstruction hierarchy of the recommended bridge systems



Figure 5-65. Removal of safety barriers

5.4.2.1 Deconstruction of Full-Depth Deck Panel Superstructure

Deconstruction of full-depth deck panels with post-tensioning is challenging compared to the other systems recommended in Section 5.1. In certain cases, depending on the condition and size of the structure, a detailed analysis of the deconstruction process should be performed including cutting of post-tensioning and carrying out a time-dependent analysis of the system. The following is the major steps involved in a deconstruction process.

8. Assess the condition of the bridge superstructure and substructure.
9. Evaluate the scour state, which may lead to instability of the structure.
10. Assess the existing condition of the grouted tendon ducts to prevent abrupt changes in post-tension load transfer when the ducts and the strands are cut. If the ducts are fully grouted, the load transfer is gradual and will not create safety concerns.
11. Conduct a detailed analysis of the deconstruction process considering the condition of the bridge, deconstruction sequence, temporary supports, and position of the lifting devices.
12. Remove overlay to locate the blockouts and panel-to-panel connections (required only when deck panels are replaced).
13. Locate blockouts with shear studs, and cut around the blockouts by using a concrete saw or hydrodemolition. Concrete that encases the shear studs can be removed by

using a hammer or hydrodemolition. Use of jack hammer is not recommended because it may damage the girders.

- Cut transverse connections first and then cut the longitudinal connections of the panels using a concrete saw. If only the deck is to be replaced, then the girders should be spared while cutting or removing the panel. Hence, cut depth needs to be carefully adjusted. Cutting post-tensioning ducts and strands should not yield to any instability situations as the girders are designed to be simply supported while carrying the dead load of deck panels.
- Remove panels by lifting once the deck is fully detached from the girders (Figure 5-66).
- Cut off existing shear studs if it is necessary (Figure 5-66). New studs can be welded (if steel girders are used in the superstructure or steel plates are provided in the top flange of the concrete girders). It is advised to protect the studs as much as possible. If a limited number of studs are needed to be replaced, drilling and installing new studs in a concrete girder is advised.
- Remove the girders after panels and the continuity detail over the piers are removed; do this by cutting or through other demolition techniques as discussed at the beginning of the section.



(a) Lifting of a deck panel



(b) Cutting off the existing steel shear studs

Figure 5-66. Replacement of deck panels (Source: Wenzlick 2005)

5.4.2.2 Deconstruction of a Superstructure with Modular Elements or Systems

The bridge superstructure elements or systems are first placed as discrete simply supported components. Then the continuity between components and over the piers or bents is established. Deconstruction is performed following the reverse order of construction after thoroughly assessing the condition of the bridge superstructure and substructure. The following major steps are recommended.

- Assess the condition of the bridge superstructure and substructure.
- Evaluate the potential for scour, which may lead to instability of the structure.
- Conduct a detailed analysis of the deconstruction process considering the condition of the bridge, deconstruction sequence, temporary supports, and position of the lifting devices.
- Remove the continuity details over the piers or bents making the spans simply supported. Potential approaches of removing continuity detail are discussed at the beginning of this section.
- Saw cut the connections between individual elements or systems.
- Attach lifting devices at predefined locations and remove the components.

5.4.2.3 Deconstruction of Bridge Substructure

Deconstruction of substructures needs to be evaluated after considering the size and weight of the components and the potential for scour at the piers and abutments. Demolishing with mechanical methods, such as hammers and pulverizers, is recommended based on the size and weight of the substructure units. Removal of debris can be minimized by performing deconstruction in the reverse order of construction. This is feasible if segments are used for abutment wall and bent caps to reduce weight.

The substructure components, such as bent caps and columns, can be brought down as a single unit by cutting at the footing level. Afterwards, they can be cut into pieces that are small enough to be transported. This technique was used in the demolition of Cooper River bridge (Figure 5-67) and demolition of the I-5 Bridge over the Willamette River in Eugene, Oregon (Figure 5-68).

Pile demolition can be carried out by mechanical methods after deciding on a suitable depth of removal. As recommended in FDOT Standard Specification for Road and Bridge Construction, removal depth of piling should be the deepest described in the permit or other contract documents, but not less than 2 ft below the finish ground line.



Figure 5-67. Demolition of a bent cap and columns as a single unit (Source: SCDOT)



Figure 5-68. Column and pier walls are sawn off and lifted out for demolition (Source: <http://www.mcgee-engineering.com>)

Intentionally left blank

6 CONSTRUCTABILITY MODEL FOR ABC PROJECTS

An ABC constructability model is developed based on constructability basics presented in Chapter 2 and performance, challenges, and lessons presented in Chapter 3. The model is structured in a list of questions. The model shown in tabular form below is intended for the project development and delivery teams' review before construction commences.

6.1 REVIEWED BY THE PROJECT DEVELOPMENT TEAM

	DESCRIPTION	YES	NO	N/A	Remarks
I	BIDDABILITY				
1.	Are agreements and any coordination in place with appropriate agencies/utilities/other affected parties?				
2.	Are permits executed and have all requirements identified been addressed on the plans (DEQ, Coast Guard, waterway, RR, regulatory, local agency, FAA, etc.)?				
3.	Is the environmental classification complete?				
4.	Is the environmental certification complete?				
5.	Did you consider involving all stake holders (designer, contractor, fabricator, utility providers, township officials, state and local police, regulating agencies etc.) during the construction process to mitigate the risks, identify and revise the methods of construction, and deliver the project on time?				
II	BUILDABILITY				
A.	Site Investigation				
1.	Has a current site survey been completed (horizontal & vertical controls)?				
2.	Was subsurface exploration performed? (soil boring, water table, etc.)				
3.	Was there a utility investigation including overhead lines?				
4.	Are the existing drainage features adequate?				
5.	Were overhead, underground, and other bridge supported utilities considered during the design phase?				
6.	Has the level/amount of deterioration identified during the original scope been rechecked? A recheck should occur if the original scope is more than 2 years old.				
7.	Did you consider locating the fabrication facility at or near the job site to minimize the construction cost and the impact of load restrictions?				
8.	Did you analyze the site constraints associated with potential construction methods?				
9.	Is this project a candidate for SPMT construction?				

	DESCRIPTION	YES	NO	N/A	Remarks
II	BUILDABILITY				
B.	Right of Way				
1.	Have any special access requirements been addressed?				
2.	Are private facilities located within the R.O.W. that need to be addressed?				
C.	Construction Staging				
1.	Did you consider using BIM in the design and construction of this project?				
2.	Have local ordinances been investigated and permits secured?				
3.	If applicable, have permit requirements been noted?				
4.	Did you consider pre-event meetings to examine every step involved in the construction?				
5.	Did you consider preparing a contingency/emergency plan for unforeseen site conditions?				
6.	Does your emergency response plan include a checklist, contact information, contracting alternatives, information sharing, and decision making hierarchy?				
7.	Is the envisioned construction method(s) compatible with the site constraints?				
8.	Did you consider involving the heavy lift contractor (i.e. SPMT) during design to facilitate the construction process?				
9.	Are skilled workers available for the project?				
10.	Did your design team review the installation details?				
11.	Have you incorporated unique design and construction aspects into the project?				
12.	For the unique aspects, have you developed an assessment and data collection plan?				
D.	Maintenance of Traffic (MOT)				
1.	Have items been reviewed on the Transportation Management Plan Project Development Checklist to determine what items are needed?				
2.	Did you review transportation logistics (i.e., practical weight limits for transporting, lifting, and placing.)? Did you consider alternative means of access to accommodate any constraints? Are the constraints clearly articulated in the specifications or on the plans?				
3.	Did you consider involving the contractor in developing MOT plans?				

	DESCRIPTION	YES	NO	N/A	Remarks
E.	Schedule				
1.	Have the regulatory permit restrictions been considered?				
2.	Did you consider incentive/disincentive provisions?				
3.	Did you analyze which delivery method minimizes construction time?				
4.	Does the standard and special specifications used in earlier projects provide sufficient clarity? Note: using tested and standard specifications minimizes probability of error and reduces construction rework.				
F.	Special Materials/Conditions				
1.	Has the presence of asbestos, hazardous waste or toxic materials been identified and addressed?				
2.	Are you using special concrete and/or grout specifications on this project?				
3.	Did you consider the compatibility between specified material and design detail requirements? (e.g., gap size to be filled)				
4.	Do quality assurance and quality control provisions in construction specifications adequately address every stage of the construction?				
5.	Did you consider using lightweight material for fabricating lighter sections?				
6.	Have you incorporated special materials and specifications?				
7.	For the special materials and specifications, have you developed an assessment and data collection plan?				

	DESCRIPTION	YES	NO	N/A	Remarks
G.	Fabrication				
1.	Did you consider standardizing the precast components to improve the efficiency of fabrication and installation?				
2.	Did you consider alternate geometries and details for connections between bridge elements or systems to improve construction efficiency?				
3.	Did you consider issues with moisture ingress for joints between bridge elements or systems to improve durability?				
4.	Did you consider installation and removal of formwork? Or did you use details that do not require formwork for connections and closures?				
5.	Did you consider using larger precast elements which will reduce the time and cost of fabrication, delivery, and erection?				
6.	Did you consider developing protocols using the BIM model or otherwise for as-built inspection?				

6.2 REVIEWED BY THE PROJECT DELIVERY TEAM

	DESCRIPTION	YES	NO	N/A	Remarks
II	BUILDABILITY				
A.	Site Investigation				
1.	Has the Engineer performed a site visit?				
2.	Has a sufficient field investigation been conducted to ascertain that the proposed contract work can be performed?				
3.	Has the site been evaluated for suitability with the identified construction method?				
B.	Right of Way				
1.	Is there sufficient R.O.W. available for all operations?				
C.	Construction Staging				
1.	Is the project phased to provide reasonable work areas and access?				
2.	Are widths of work zones and travel lanes adequate?				
3.	Are heights of the work zones and travel lanes adequate?				
4.	Does staging cause special conditions (structural adequacy/stability, etc.)?				
5.	Are any proposed adjacent contracts, restrictions, and constraints identified and accounted for?				
6.	Can the details as shown on the plans be constructed using standard industry practices, operations, and equipment?				
7.	Can construction-staging operations be carried out according to the maintenance of traffic plan?				
8.	Can drainage be maintained through each stage?				
9.	Did you consider simulating or testing the lift operation prior to the scheduled move? Did you consider using advanced positioning sensors such as GPS during the PBES assembly?				
10.	Did you develop a plan of action in case damage occurred during lift operation?				
11.	Did construction specifications define mixing, placing, and curing procedures for grout and/or special concrete?				

	DESCRIPTION	YES	NO	N/A	Remarks
12.	Did you evaluate the suitability of the construction specifications for grouting and/or special concrete operations related to connection details?				
13.	Did you consider/analyze tolerance issues as they relate to pre-stress/post-tensioning operations?				
14.	Did you carefully analyze tolerance issues related to the assembly and/or connectivity of the precast components? Did you check elevations? (e.g., review/analysis of tolerance issues related to the locations of shear connectors when using precast deck panels)				
15.	Did you evaluate the compatibility of the construction method(s) with the site constraints? (e.g., the working radius and location of cranes)				
D. Maintenance of Traffic					
1.	Are there adequate provisions for access for pedestrians and abutting properties?				
2.	Are there adequate provisions for emergency providers?				
3.	Are there adequate provisions for water traffic?				
4.	Have delays been estimated and provisions made to minimize them?				
E. Schedule					
1.	Is the length of time and production rate for work reasonable?				
2.	Are there any restricted hours and have their impact on schedule been considered?				
3.	Have other contracts in the area been considered and how they affect this project (i.e., trucking routes, accessibility, traffic control)?				
4.	Does the schedule consider long lead-time for ordering materials?				
5.	Is the shop drawing review time considered?				
6.	Are night and weekend work proposed, and if so are the impacts considered?				
7.	Is sequence of construction reasonable?				
8.	Have seasonal limits on construction operations been considered and accounted for?				
9.	Does the utility relocation schedule fit into the overall schedule?				

	DESCRIPTION	YES	NO	N/A	Remarks
F.	Special Materials/Conditions				
1.	Have soil erosion/sedimentation issues been addressed?				
2.	Are any special (unique/proprietary) materials, methods or technologies required for the contract?				
3.	Have all environmental constraints been avoided and restrictions been adhered to?				
4.	Did construction specifications define mixing, placing, and curing procedures for grout and/or special concrete?				
5.	Did you evaluate the suitability of the construction specifications for grouting and/or special concrete operations related to connection details?				
G.	Staffing				
1.	Are there any special operations that would require inspection specialists?				
2.	Is the budget adequate to cover construction engineering costs for the project?				
III	General				
1.	Have you incorporated unique design, construction, and material aspects to the project?				
2.	If the answer to the above question is 'yes', have you developed an assessment and associated data collection plan for the unique design, construction, and material aspects of the project?				

6.3 SUMMARY

Accelerated bridge construction (ABC) is gaining acceptance across the U.S. Constructability reviews will assist in ensuring that projects are completed in the most efficient and cost effective manner by simply reducing errors. In this study, a comprehensive ABC constructability model was developed based on constructability basics and challenges and lessons learned reported in the literature. Two difficulties faced in developing the ABC constructability model are:

- Availability of limited number of case study reports on ABC projects because ABC is new to the industry, and
- Finding adequate and necessary details on some of the case studies documented in the literature.

Nevertheless, the constructability model presented in this report is of significant resource for future ABC implementations by providing guidance to project planners, designers, and constructors. The model will need to be fine-tuned as more ABC projects are completed and documented. A post-construction program for ABC projects that properly document challenges and lessons learned will provide the data for continual refinement/revision of the constructability model.

Intentionally left blank

7 SUMMARY, CONCLUSIONS, AND RECOMMENDATIONS

7.1 SUMMARY AND CONCLUSIONS

The project goal was to analyze prefabricated bridge elements and systems (PBES) and accelerated bridge construction (ABC) technology for implementation; it was also to develop technology implementation recommendations to assure constructability, durability, repairability, and maintainability. In addition, recommendations for follow-up projects are described in order to further improve effectiveness and efficiency of new technology implementations.

The first task was to review and synthesize the state-of-the-art practices in using (1) PBES in ABC, (2) connection details between prefabricated components, (3) available cementitious grout material for the connections and their application procedures, (4) equipment and methods for accelerated construction and deconstruction, (5) constructability review process (CRP) or constructability program, and (6) decision-making models. The synthesized knowledge base compiled from the literature review developed the basis of the subsequent tasks. The subsequent tasks were to develop recommendations for PBES and connection details for Michigan exposure, developing a Michigan-specific ABC decision-making process, a constructability review checklist for ABC implementations, and a special provision template for grout selection and application. The literature review is presented in Chapter 2.

The performance of earlier ABC implementations was reviewed. Previous ABC implementations were categorized into three groups:

- (1) full-depth deck panel systems,
- (2) deck integrated prefabricated modules (box-beams) to develop side-by-side box-beam systems, and
- (3) Self Propeller Modular Transporters (SPMT), or the slide-in technique, to move a complete bridge superstructure into place.

Recommendations are presented in Chapter 3 to assure the long-term durability of PBES. Recent ABC projects were also reviewed, and lessons for future implementations are described. The lessons learned were synthesized and categorized as (1) project planning, design and tolerances, (2) precast element fabrication procedures, and (3) construction

operation and methods. One outcome of analysis of recent projects together with the synthesis provided in the literature review was the basis for the development of a constructability review checklist for ABC projects.

To advance the available decision-making processes, a multi-criteria decision-making process and the associated software platform was developed. The software is called Michigan Accelerated Bridge Construction Decision-Making (Mi-ABCD) that compares the Accelerated Bridge Construction (ABC) to Conventional Construction (CC) alternatives for a particular project. The decision-making process incorporates project-specific data and user-cost and life-cycle cost models to provide input to the users with quantitative data. The software platform was developed on Microsoft Excel and Visual Basic for Applications (VBA) scripts. A user manual was also prepared and included in Appendix E. The multi-criteria decision-making process developed during this project provides solutions to many issues in ABC decision-making. The decision-making framework calculates the *preference rating* of each construction alternative. The contribution of major parameters to the *preference ratings* is also displayed. The decision-making platform features developed in this project is a significant advancement over the available decision-making models.

Connection details for the prefabricated bridge elements and systems and grout or special mixes suitable for the connections and for the Michigan climate are developed and included in the report. Following the synthesis of the state-of-the-art practices and performance and lessons learned from ABC implementations, PBES with potential for immediate implementation are classified. Implementation potential for PBES is based on constructability, maintainability, reparability, and durability (CMRD). Suitable connections between the PBES are identified considering Michigan exposure, load transfer mechanism, constructability, durability, dimensions and tolerances. The PBES and associated connections recommended for Michigan, attributes of PBES, connection details, formwork for grout or special mix placement, construction complexities, and additional limitations are presented in Chapter 5. Above all, standard details for longitudinal connections at the deck level are developed for bridge superstructures with precast, prestressed concrete girders. Addressing the constructability issues due to weight of substructure components, reduced-weight options are identified and presented in Chapter 5.

Nonspecific grout or special mix recommendations for a connection are not practical because the material selection needs to be based on project or design specifics. Examples of related project specifics are (1) site specific exposure conditions, (2) grout pocket dimensions, (3) application procedures and limitations, (4) curing requirements and also (5) grout properties such as compressive strength, volume stability, initial setting time or working time, and working temperature range. It is recommended that grout needs to be tested and evaluated for the particular application before field implementation. In order to streamline the grout specification process, a template of special provisions for grout selection and application is developed and presented in Appendix J. Further, development of a database of material properties suitable for the connection between prefabricated components is recommended. This database needs to be available to designers as discussed and presented in Chapter 5.

An ABC constructability review checklist is compiled. The checklist will help guide the project development and delivery teams in constructability assessments prior to the bidding process. The checklist will also help reduce errors as observed in earlier ABC implementations. It can be a project management, scheduling, and cost control tool.

7.2 RECOMMENDATIONS

The recommendations developed in this project are specific to (1) the Michigan specific decision-making platform, (2) PBES suitable for Michigan, (3) PBES connection details, (4) grout and special concrete mix specifications, and (5) the constructability review checklist.

- 1) The next version of the decision-making platform capability needs to include comparisons of different ABC alternatives with conventional construction.
- 2) The PBES suitable for Michigan are categorized as i) suitable for immediate implementation and ii) suitable for implementation with additional investigations.
 - The PBES suitable for immediate implementation are as follows:
 - PC I and bulb-tee girders: A widely used girder type with standard details. In the context of ABC, these multigirder systems can only accommodate the full-depth deck panels.
 - Full-depth deck panels with transverse prestressing and longitudinal post-tensioning: The transverse prestressing is required for panel crack control. An accurately designed and constructed deck system with longitudinal post-tensioning

will achieve superior durability performance. Durability performance failures are often related to flawed grouting of connections. Other problems reported are related to repair and rehabilitation difficulties due to the post-tensioning. With regard to limitations on repair and rehabilitation with the post-tensioning, it is best to implement this system at sites where girder damage (e.g., high-load hits) is unlikely.

- Decked bulb-tee girders: Bridge can be designed with or without an overlay. The forms for casting the precast bulb-tee girders can be modified for the decked section. Problems include the performance weakness of the system associated with the empirically designed longitudinal connections. This report addresses this by presenting rationally designed standard longitudinal connection details.
- Decked box beams: This system is recommended based on the Michigan DOT's favorable experiences. The difficulty is the multi-step fabrication process required for casting this section. Box beams are standardized; hence, the formwork is available. Fabrication difficulties can be overcome by modifying the box beam formwork for the decked sections. Similar to all PBES, durability performance of the decked box section is also controlled by the details and grouting quality of the longitudinal connections. Rationally designed standard details for flexure-shear transfer connections is also presented in this report.
- Decked steel girder system: This system is developed through a SHRP II project. The system is non-proprietary, and fabrication appears simple. The shallow depth makes the section suitable for sites with underclearance limitations. Further, the construction does not require any specialized equipment. To be cost effective, the section steel girder fabrication and precasting of the deck can be performed at a nearby staging area. Durability performance of the system is again controlled by the details and grouting quality of the longitudinal connections. Connection redesign to accommodate both moment and shear transfer is recommended.
- Precast abutment stem: Two different sections are recommended. The primary limitation is the weight of the stems. To minimize the weight, a stem fabricated with cavities is recommended. The cavities can be filled with concrete following

placement. Another option is segmental stems that are spliced in the field. The segmental stems can be utilized for sites with limited access or space.

- Precast columns: Rectangular, square, and octagonal sections are recommended considering fabrication and transportation difficulties with circular sections. On the other hand, the precast industry needs to innovate in order to manufacture circular products efficiently and cost effectively, for example, by using centrifugal force during concrete placement to form the circular cross-section.
- Precast pier/bent cap: The primary limitation is the weight of the segments. Bent caps can be fabricated in different lengths to overcome the weight limitations. Reduced-weight alternatives are presented in the report. Some state agencies have developed standard details for pier and pier caps, two column bent, or a three column bent. Developing standard pier and bent cap details for MDOT applications is recommended.
- The recommended PBES strategies that require additional investigation before being implemented in Michigan are as follows:
 - Precast adjacent box beams: This bridge system has been implemented since the 1950's. Additional investigations and subsequent redesign is required to resolve durability performance problems with the girder, longitudinal joints, and the deck.
 - Inverted-T precast slabs: This system, with high span-to-depth ratio, is suitable for projects with underclearance limitations. The connection between the units is prone to cracking. The NCHRP-10-71 project proposed new details to prevent cracks from forming. These proposed details have not been tested nor their performance monitored. Further investigation is required prior to recommending the system.
 - Northeast Extreme Tee (NEXT) D beams: This section possesses higher load carrying capacity than standard double tee girders. The concerns related to undefined live load distribution and the lack of optimality of the cross-section requires further investigation.
 - Precast pier/bent cap with cavities: The sections developed with cavities are of reduced weight. However, the section is not widely used and requires further investigations. Prestressing was also identified as an option to increase bend cap

capacity; thus, the section can be reduced for lower weight. This requires a detailed study on performance and cost comparison.

- Precast segmental piers: Using segmental piers resolves problems associated with weight and size, transportability, site accessibility, and space constraints. Further investigation is required to identify a suitable section type and size for short and short-to-medium span bridges.

3) Considering i) Michigan exposure conditions, ii) the load transfer mechanism of the connections, iii) constructability, iv) connection dimensions and tolerances (to ensure construction quality), and v) other details such as formwork for grouting, the following details are recommended.

- The superstructure connection details are classified into five groups given below:
 - *Transverse connection at the deck level*: This detail is typically used in the full-depth deck panel system. Transverse connection between panels is typically unreinforced and requires post-tensioning for moment and shear transfer. Considering the tolerances, space for grouting, and adequate confinement of the grout to transfer shear, the recommended connection details are presented in Section 5.2.1.1.
 - *Longitudinal connection at the deck level*: Longitudinal connection at the deck level requires two layers of reinforcement for moment transfer. The standard details developed by a rational design process are presented in Section 5.2.1.2, and they are recommended for systems such as full-depth deck panels, decked bulb-tee, decked box-beam, and NEXT D beams. The reinforced joint can be formed using high early strength concrete or suitable grout with properties compatible to concrete.
 - *Deck-to-girder connection*: This detail is typically used in a full-depth deck panel system to connect the panel to the girder. In Section 5.2.1.3, connection details are recommended for both steel and concrete girder systems. A panel support system and flexible formwork are recommended.
 - *Continuity detail over a pier or a bent*: Details for a full moment connection and link slabs over a pier or bent are recommended. Section 5.2.1.4 presents the details

and a discussion of limitations in using such details. Considering the deconstruction process discussed in Section 5.4.2, link slabs over the piers and bents are recommended.

- *Continuity detail at abutment:* A semi-integral abutment detail with an approach and sleeper slab is recommended. This recommendation is based on future bridge superstructure replacement needs and associated design, construction, and deconstruction simplicity. Details are presented in Section 5.2.1.5.
- The substructure connections are classified into five groups as given below:
 - *Pile cap or abutment cap to pile:* The recommended connection details presented in Section 5.2.2.1 include moment and shear transfer connection with grouted pockets formed with corrugated metal at the pile cap or abutment cap. In this connection, an access hole at the top of the pile cap or abutment cap is required for grout placement by gravity. A temporary support system is also recommended for the pile cap or abutment cap so that the construction activities can be performed without delay, while the grouted connection gains sufficient strength. However, vibration propagating from construction activities may impact grout strength and interface bond development at the connection.
 - *Column to footing:* Two types of connection details are recommended in Section 5.2.2.2. These are (1) a grouted splice sleeve and a socket at the footing level and (2) a pocket connection with a shear key. Neat grout is recommended for splice sleeves and extended grout; high early strength concrete is recommended for larger voids in a pocket connection.
 - *Abutment wall to footing:* A grouted splice sleeve connection is recommended in Section 5.2.2.3. Alignment of extended rebars with the splice sleeves may present difficulties during prefabrication.
 - *Pier cap or bent cap to pier or column:* Three connection types are recommended in Section 5.2.2.4. These are (1) a grouted pocket with two layers of reinforcement, (2) a grouted corrugated duct connection, and (3) a vertical splice duct connection. The details with a designed bearing surface between components allow construction activities to proceed without delay while grout or special mixes

achieve the minimum required strength. However, vibration propagating from construction activities may impact strength and interface bond development at the connection.

- *Vertical connection between elements (splice)*: Splicing of components can control the size and weight of substructure units as discussed in Section 5.2.2.5. The details recommended are those that transfer both moment and shear. The construction difficulties presented in Section 5.2.2.5 include space limitations and conflict between reinforcement. In recently completed projects, splice reinforcement was in conflict and needed to be bent at the field. With the knowledge of construction difficulties, the designers and fabricators can resolve potential conflicts during the design phase.

4) Grout selection, application procedures, and curing requires consideration of (1) connection details, (2) strength, serviceability, and durability requirements, (3) site exposure, and (4) construction schedule. A grout property database, if developed, will significantly simplify the preparation of special provisions. A template of detailed special provisions to address grout selection, testing, application, curing or protection, quality control, and reporting is developed and included in Appendix J.

5) The recommendations to enhance constructability are as follows:

- Implement the constructability review checklist in ABC projects as it can play a significant role in guiding the project planners, designers, and constructors.
- Refine the constructability review checklist using “Total Quality Management” principles and the data collected during recent ABC projects.
- Develop a post-construction report template for ABC projects to properly document the difficulties and lessons learned as part of a “Total Quality Management” process.

7.3 RECOMMENDATIONS FOR IMPLEMENTATION

During this project, several tasks were identified that will expedite MDOT's implementation of PBES. These tasks are described below:

- 1) The Michigan-specific ABC decision making platform needs to be upgraded to include comparisons of ABC alternatives.
- 2) In order to promote a system-wide PBES implementation, an inventory-specific PBES can be developed including substructure components for MDOT and local agency bridges. A Michigan bridge inventory can be classified with respect to span ranges, skew, and additional inventory classification parameters. Bridges can be classified with respect to span [short (<60 ft), short-to-medium (60 – 130 ft), and medium span (130 - 260 ft)] and skew [skew <20⁰, 20⁰< skew <30⁰, 30⁰< skew <45⁰, 45⁰< skew <60⁰]. A project can be initiated to identify and specify PBES option(s) appropriate for each classification. Substructure components can also be specified, and conceptual configurations and details can be developed. The conceptual configurations will help resolve some of the difficulties such as component weight, transportation, and connection details. Several conceptual substructure configurations are identified:
 - i) Discrete piers to support girders without the need for a continuous bent cap. The design requires identifying and evaluation of transverse girder end diaphragm options for stability and developing design examples and details.
 - ii) Discrete piers to support girder ends with integrated backwall to develop semi-integral systems. Precast wall panels can be used with discrete columns to retain the backfill. This detail requires developing design details, testing, and verification, and developing design examples.
 - iii) Limited length bent caps (e.g., bent caps that are supported by single, two, or three columns).
 - iv) Prestressed bent caps.
 - v) Precast approach slabs for semi-integral bridges.

This proposed project will be the intermediary step towards standardizing PBES and associated substructure components.

- 3) There is a lack of information available to the designer in specifying grout or special mixes for the connections between prefabricated components. The current practice of specifying the material in general terms, such as non-shrink grouts, creates difficulties during construction. Development of a material database is recommended for use of design engineers and contractors.
- 4) The increase use of PBES within MDOT and local agency inventory requires updated inspection procedures to include processes specific to prefabricated bridge systems. The updated inspection and reporting procedures will require including child tables to already existing parent tables such as deck and substructure. Information related to superstructure type such as a full-depth deck, a deck with modular elements, and a deck with modular systems can be included in the child table under the deck. An additional table may include component, connection, and continuity detail-specific ratings and inspector comments. Extending the inspection database in this fashion helps in implementing an effective and efficient bridge management program specific to PBES. Further, PBES in a few cases will require the use of advanced NDE techniques for inspection especially to assess the integrity of concealed connections. Hence, it is also recommended to develop a NDE toolkit for inspection of bridges built with PBES.
- 5) An increased number of bridges constructed using PBES requires developing a structure-specific matrix for initiating bridge management activities of Capital Preventive Maintenance (CPM), Capital Scheduled Maintenance (CSM), and Repair and Replacement (R&R). Further, the use of PBES bridges requires reevaluating current repair and rehabilitation techniques and procedures. Hence, it is recommended to develop a PBES specific *MDOT Bridge Deck Preservation Matrix* and an associated document specifying techniques and procedures of repair and rehabilitation

8 BIBLIOGRAPHY

AASHTO (2000). *Constructability review best practice guide*, American Association of State Highway and Transportation Officials (AASHTO), Washington, D.C.

AASHTO (2010). *LRFD Bridge Design Specifications*, Customary U.S. Units, 4th Ed., American Association of State Highway and Transportation Officials, Washington, DC.

AASHTO. (2011). "Michigan DOT – Drivers hold key to safety in work zones." *American Association of State Highway and Transportation Officials (AASHTO) Journal–Weekly Transportation Report*, <<http://www.aashtojournal.org/Pages/061711michigan.aspx>> (June 09, 2011)

Abudayyeh, O. (1997). "Safety issues in bridge demolition projects: A case study." *PM network, Proj. Mgmt. Inst.*, Sylva, N.C., 11(1).

Abudayyeh, O., Sawhney, A., El-Bibany, H., Buchanan, D. (1998). "Concrete bridge demolition methods and equipment." *Journal of Bridge Engineering*, 3(3), 117-25.

Abudayyeh, O., Cai, H., Mellema, B. and Yehia, S. (2010a). "Quantifying Time and User Cost Savings for Rapid Bridge Construction Technique." *Transportation Research Board*, 2151, 11–20.

Abudayyeh, O. (2010b). *A Sensor Network System for the Health Monitoring of the Parkview Bridge Deck*, Final Report RC 1536, Michigan Department of Transportation, Construction and Technology Division, Lansing, MI,

Abudayyeh, O., Aktan, H., Abdel-Qader, I., and Attanayake, U. (2012). *Development and validation of a sensor-based health monitoring model for the Parkview bridge deck*, Michigan Department of Transportation, Construction and Technology Division, Lansing, MI.

Aktan H., Ahlborn T. M., Attanayake, U., Ulku, E., and Deshpande, Y. (2009). *Condition Assessment and Methods of Abatement of Prestressed Concrete Box-Beam Deterioration*, Phase II Report RC-1527, Michigan Department of Transportation, Construction and Technology Division, Lansing, MI.

Aktan H. M., Ahlborn T. M., Kasper J. M., Koyuncu Y., Rutyna J. (2002). *Causes & Cures for Prestressed Concrete I-Beam End Deterioration*, Report RC-1412, Michigan Department of Transportation, Construction and Technology Division, Lansing, MI.

Aktan, H., Ahlborn, T. M., Attanayake, U., Gilbertson, C. G. (2005). *Condition Assessment and Methods of Abatement of Prestressed Concrete Box-Beam Deterioration*, Phase I Report RC-1470, Michigan Department of Transportation, Detroit, MI.

Aktan, H., and Attanayake, U. (2011). *High Skew Link Slab Bridge System with Deck Sliding over Backwall or Backwall Sliding over Abutments*, Final Report RC 1563, Michigan Department of Transportation, Construction and Technology Division, Lansing, MI.

Anderson, D.R., Williams, T.A., Sweeney, D.J. (2005). *An Introduction to management Science – Quantitative approaches to decision making*, 11th Ed., Thomson – South Western, Mason, Ohio, 732–743.

Anumba, C., Abdullah, A., Fesseha, T. (2003). “Selection of demolition techniques: a case study of the Warren Farm Bridge.” *Structural Survey*, 21 (1), 36-48.

Archer Company (2011). <<http://www.archerusa.com>>(Jun. 28, 2012).

Ardani, A., Mallela, J., Hoffman, G. (2009). *Utah Demonstration Project: Rapid Removal and Replacement of the 4500 South Bridge over I-215 in Salt Lake City*, Final Report, Federal Highway Administration, Salt Lake City, Utah.

Ardani, A.A., Lindsey, R. and Mallela, J. (2010a). “One Weekend Job - Rapid removal and replacement of 4500 South Bridge in Salt Lake City, Utah.” *Transportation Research Record: Journal of Transportation Research Board*, 2200, 12–16.

Ardani, A., Mallela, J., and Hoffman, G. (2010). *Oregon Demonstration Project: Alternate Project Delivery and Accelerated Bridge Construction on OR38, Drain to Elkton*, Draft Final Report, Federal Highway Administration, Salem, Oregon.

Arditi, D., Elhassan, A. and Toklu, Y.C. (2002). “Constructability analysis in the design firm.” *J. of Constr. Engr. and Mgmt.*, ASCE, 128(2), 117-126.

Attanayake, U. (2006). *Macromechanical modeling of precast orthotropic bridge superstructure systems*, Ph.D Dissertation UMI Microform 3225817, Wayne State University, ProQuest Information and Learning Company, Ann Arbor, MI.

Attanayake, U., Abudayyeh, O., Cooper, J., Mohammed, A. W., and Aktan, H. (2012). “The First Full-Depth Deck Panel Accelerated Bridge Construction Project in Michigan: Constructability Challenges and Lessons Learned.” *The Journal of Performance of Constructed Facilities*, (in print).

Badie, S.S., Kamel, M.R., and Tadros, M.K. (1999). “Precast pretensioned trapezoidal box beam for short span bridges.” *PCI Journal*, Jan.-Feb., 48–59.

Badie, S.S., Tadros, M.K., and Girgis, A.F. (2006). *Full-depth, precast concrete bridge deck panel systems*, NCHRP report 12-65, National Cooperative Highway Research Program (NCHRP) and Transportation Research Board, Washington, D.C.

Bardow, A.K., Seraderian, R.L., and Culmo, M.P. (1997). “Design, fabrication, and construction of the New England Bulb-tee girder.” *PCI journal*, Nov-Dec, 30–40.

Beacham, M., and Derrick, D. (1999). “Longer bridge spans with Nebraska’s NU I-girders.” *TRNews - Nebraska Department of Roads*, May-June (202).

Bell II, C.M., French, C.E., and Shield, C.K. (2006). *Application of Precast Decks and other Elements to Bridge Structures*, Report MN/RC-2006-37, Research Services Section, Minnesota Department of Transportation, Saint Paul, MN.

Bierwagen, D. (2009). "UHPC in Iowa." Office of Bridges and Structures, Iowa Department of Transportation.
<<http://www.iowadot.gov/operationsresearch/lunchandlearn/2009/sept/Research%20Office%209-21-09.pdf>> (Jun. 28, 2012).

Billington, S.L., Barnes, R.W., and Breen, J.E. (1999). "A precast segmental substructure system for standard bridges." *PCI Journal*, July-August, 56–64.

Billington, S.L., Barnes, R.W., and Breen, J.E. (2001). "Alternate substructure systems for standard highway bridges." *J. of Bridge Engg, ASCE*, 6(2), 87–94.

Biswas, M. (1986). "Special report – Precast bridge deck design systems." *PCI Journal*, March-April, 40-66.

Blanchard, B., Espino, E., Schneiderman, J., and Finley, R.C. (2010). "Segmental bridge construction." *Proc., FDOT/FTBA Construction Conference*, Orlando, FL.

Bonstedt, H. (2010). "A presentation on Life-cycle cost analysis for bridges – In search of better investment and engineering decisions." *Proc., Prestressed Concrete Association of Pennsylvania*, PA.

Browder, J. (2007). "Route 33 bridges: Overview and construction issues." *Proc., 2007 Virginia Concrete Conference*, Richmond, VA.

BSI (2000). *Code of Practice for Demolition*, British Standart Institute (BSI).

Calabrese, D. (2000). "Hydrodemolition takes on the Jackhammer." *AK Services, Inc. – Waterjetting and Hydrodemolition Specialists*,
<http://www.akservices.com/franson_article.htm> (Apr. 04, 2012).

Caltrans. (2008). "San Francisco - Oakland Bay Bridge east span seismic safety project." *Proc., Bay Area Toll Authority and California Transportation Commission, California Department of Transportation (Caltrans)*, CA.

Calvert, E. (2010). "Modified Florida double T bridge for accelerated bridge construction." *Proc., FACERS Annual Meeting*, Tampa, FL.

Carson, J.L., Anderson, S.D., Ullman, G.L. (2008). "Matrix-Based Decision Support Tools for Construction Activities on High-Volume Roadways." *Transportation Research Record: Journal of the Transportation Research Board*, Washington, D.C., 2081, 9–28.

Castrodale, R.W., and White, C.D. (2004). *Extending span ranges of precast prestressed concrete girders*, NCHRP report 517, National Cooperative Highway Research Program (NCHRP) and Transportation Research Board, Washington, D.C.

CCI. (2004). “Weathering steel – connecting with the environment.” *Corus Construction and Industrial (CCI)*, <www.corusconstructionandindustrial.com> (Apr. 24, 2012).

Chan, A., Keoleian, G., and Gabler, E. (2008). “Evaluation of life-cycle cost analysis practices used by the Michigan Department of Transportation.” *J. of Trans. Engr., ASCE*, 134(6), 236–245.

Chamberland, M., and Patel, B. (2011). “Reconstruction of Eastern Avenue Bridge.” *Rebuilding America’s Infrastructure*, <<http://www.rebuildingamericainfrastructure.com/>> (Oct. 18, 2011).

Charter III, J.W., Hubbard, F.K., Oilva, M., Pilgrim, T. and Poehnelt, T. (2007). “Wisconsin’s use of full-depth precast concrete deck panels keeps Interstate 90 open to traffic.” *PCI Journal*, Jan.–Feb., 2–16.

Chung, P., Wolfe, W.R., Ostrom, T., Hida, S., Speer, D., Franklin, A., Wahbeh, M., Pohll, M., Masroor, T., Wang, L., Soim, P., Ibrahim, A.M.M., Nguyen–Tan, D., Ma, J., Pope, M. (2008). *Accelerated Bridge Construction Applications in California*, Lessons Learned Report v1.1, Caltrans Engineering Services, California Department of Transportation, CA.

CII (1993). *Constructability implementation guide*, Special Pub. 34-1, Construction Industry Institute (CII), Austin, Texas.

Civil Engineer. (2011). “Construction Risks Analysis and Management.” *Project Management–Civil Engineering Blog*, <<http://civilengineerblog.com/construction-risks-analysis-management/>> (Mar. 28, 2011).

COP. (2007). “TRIP – Turnpike roadway information program.” *Commonwealth of Pennsylvania (COP)*, <<http://www.paturnpike.com>> (Apr. 14, 2009).

CPCI. (2006). “Provencher Bridges in Winnipeg, Manitoba, Canada.” *Canadian Precast/Prestressed Concrete Institute (CPCI)*, <<http://www.cpci.ca/?sc=potm&pn=monthly42006>> (Mar. 21, 2012).

CPMP. (2011). “Product Brochures.” *Central Pre-Mix Prestress (CPMP)*, <<http://www.cprestress.com/engineering-details>> (Feb. 04, 2012).

Culmo, M.P. (2009). *Connection Details for Prefabricated Bridge Elements and Systems*, Technical Report FHWA-IF-09-010, Federal Highway Administration, McLean, VA.

Culmo, M. P. (2010). *Performance of Accelerated Bridge Construction Projects in Utah as of June 2010*, Lessons Learned Report, Utah Department of Transportation, Salt Lake City, UT.

Culmo, M.P., and Seraderian, R.L. (2010). “Development of the northeast extreme tee (NEXT) beam for accelerated bridge construction.” *PCI Journal*, Summer, 86-101.

Culmo, M.P. (2011). *Accelerated bridge construction – Experience in design, fabrication and erection of prefabricated bridge elements and systems*, Report FHWA-HIF-12-013, Federal Highway Administration (FHWA), McLean, VA.

Doolen, T. (2011). “To Accelerate Bridge Construction or Not? A planning Phase Decision Tool for ABC.” *Proc., National Highway Institute (NHI) Innovations webinar*, Oregon State University, Corvallis, OR.

Dunston, P. S., Gambatese, J.A., McManus, J. F. (2005). “Assessing State Transportation Agency Constructability Implementation.” *J. of Const. Engr. and Mgmt.*, ASCE, 131(5), 569–

Ehlen, M.A., and Marshall, H.E. (1996). *The Economics of New-Technology Materials: A Case Study of FRP Bridge Decking*, Report NISTIR 5864, National Institute of Standards and Technology (NIST), U.S. Department of Commerce Technology Administration, Gaithersburg, MD.

El-Diraby, E. and O’Connor, T. J. (2001). “Model for evaluating Bridge Construction Plans.” *J. of Const. Engr. and Mgmt.*, 127(5).

Ereti, M.Y. (2010). “History of the Highway Capacity Manual.” *Proc., TexITE – Houston chapter, Department of Public works & Engineering*, Houston, TX.

Fallaha, S., Sun, C., Lafferty, M.D. and Tadros, M.K. (2004). “High Performance Precast Concrete NU-deck Panel System for Nebraska’s Skyline Bridge.” *PCI Journal*, Sept.-Oct., 40–50.

FHWA. (2012). *Mid-North Regional Peer-to-Peer Exchange Final Report*, Federal Highway Administration, Washington, D.C.

FHWA. (2011). “Prefabricated Bridge Elements and Systems: PBES Innovative Projects.” *Federal Highway Administration (FHWA) – Every Day Counts*, <<http://www.fhwa.dot.gov/bridge/prefab/all.cfm?view:1>>

FHWA (2006). “Prefabricated bridge elements & systems cost study–Accelerated bridge construction success stories.” *Federal Highway Administration*, <<http://www.fhwa.dot.gov/>> (Aug. 12, 2010).

Forman, E. H. and Selly M. A. (2000). *Decision by Objectives*, Expert Choice Inc., Pittsburgh, PA.

Fort Miller Co. (1998; 2010). *Inverset™ Bridge System – design, installation and technical manual*, Product literature, Fort Miller Company, Inc., Schuylerville, NY.

Fouad, F.H., Rizk, T., Stafford, E.L., and Hamby D. (2006). *A Prefabricated Precast Concrete Bridge System for the State of Alabama*, University Transportation Center for Alabama and University of Alabama, Tuscaloosa, AL.

French, C.E., Shield, C.K., Klaseus, D., Smith, M., Eriksson, W., Ma, J.Z., Zhu, P., Lewis, S., and Chapman, C.E. (2011). *Cast-in-Place Concrete Connections for Precast Deck Systems*, Contractor's Final Report, NCHRP Project 10-71, National Cooperative Highway Research Program, Transportation Research Board of the National Academies, Washington, D.C.

Freyermuth, C.L. (1997). "AASHTO-PCI-ASBI segmental box girder standards: A new product for grade separations and interchange bridges." *PCI Journal*, Sept.-Oct., 32-42.

Gambatese, J. A., Pocock, J. B., and Dunston, P. (2007). *Constructability Concepts and Practice*, American Society of Civil Engineering, Reston, Virginia.

Gary, J., and Jorge, A. (2002). "The Bridges that good planning and execution rebuilt." *Public Roads, Turner-Fairbank Highway Research Center*, McLean, Virginia, 66 (2).

Geren, K.L., and Tadros, M.K. (1994). "The NU precast/prestressed concrete bridge I-girder series." *PCI Journal*, May-June, 26-32.

Gilley, R., Mallela, J., Hoffman, G., and Ullman, G. (2009). *Virginia Demonstration Project: Rapid Removal and Replacement of U.S. 15/29 Bridge Over Broad Run Near Gainesville, VA*, Final Report, Federal Highway Administration. Richmond, Virginia.

Graybeal, B.A. (2009). *Structural Behavior of a 2nd Generation UHPC Pi-girder*, Report PB2009-115496, Federal Highway Administration, Springfield, VA.

Graybeal, B.A. (2010a). *Behavior of field-cast ultra-high performance concrete bridge deck connections under cyclic and static structural loading*, Report. FHWA-HRT-11-023, Federal Highway Administration, Washington, D.C.

Graybeal, B.A. (2010b). "Behavior of Ultra-High Performance Connections between Precast Bridge Deck Elements." *Proc., Concrete Bridge Conference*, 1-13.

Griffith, A and Sidwell, A.C. (1997). "Development of constructability concepts, principles and practices." *Engineering, Construction and Architectural Management (ECAM)*, Blackwell, 4(4), 295-310.

Gulyas, R.J., Wirthlin, G.J., and Champa, J.T. (1995). "Evaluation of Keyway Grout Test Methods for Precast Concrete Bridges." *PCI Journal*, Jan.-Feb., 44-57.

Hanna, K.E., Morcous, G., and Tadros, M.K. (2010a). *Second generation precast deck panel (NU-deck) system*, Final Report, Nebraska Department of Roads (NDOR) and University of Nebraska-Lincoln, Omaha, NE.

Hanna, K.E., Morcous, G., and Tadros, M.K. (2010b). *Design Aids of NU I-girder Bridges*, Final Report, Nebraska Department of Roads (NDOR) and University of Nebraska-Lincoln, Omaha, NE.

HBO. (2003). "Bridge browser-Seneca bridge." *Historic Bridges .org*.

<<http://www.historicbridges.org/bridges/browser/index.php?bridgebrowse>> (Sept. 20, 2010).

HCM (2000). *Highway Capacity Manual (HCM) 2000 –U.S. customary units*, Transportation Research Board, National Research Council, Washington, D.C.

Hieber, D.G., Wacker, J.M., Eberhard, M.O., Stanton, J.F. (2005). *State-of-the-Art Report on Precast Concrete Systems for Rapid Construction of Bridges*, Report WA-RD 594.1, Washington State Transportation Center, Seattle, WA.

Higgins, C. (2010). “Accelerated Bridge Construction: Tradition meets innovation at the Utah department of transportation.” *ASPIRE*, Fall, 44–47.

IMECO. (2011). “Hydraulic Impact Hammer SuperRAM.” *Products*, <<http://www.imeco.at/index.php?id=pil06>> (Aug. 21, 2011).

IowaDOT. (2011). “SHRP 2 Demonstration – U.S. 6 Bridge over Keg Creek Project Information.” *Iowa Department of Transportation (IowaDOT) and Transportation Research Board*, <<http://www.iowadot.gov/us6kegcreek/plans.html>>

Issa, M.A., Idriss, A.T., Kaspar, I.I., Khayyat, S.Y. (1995a). “Full Depth Precast and Precast, Prestressed Concrete Bridge Deck Panels.” *PCI Journal*, 59-69.

Issa, M.A., Issa, M., Khayyat, S.Y., Yousif, A.A., Kaspar, I.I. (1995b). “Field performance of full depth precast concrete panels in bridge deck reconstruction.” *PCI Journal*, 82-108.

Issa, M.A., Ribeiro do Valle, C.L., Islam, S., Abdalla, H.A., and Issa, M.A. (2003). “Performance of Transverse Joint Grout Materials in Full-Depth Precast Concrete Bridge Deck Systems.” *PCI Journal*, July-August, 2-13.

Issa, M.A., Anderson, R., Domagalski, T., and Islam, M.S., Asfour, S., Islam, M.S. (2007). “Full-scale testing of prefabricated full-depth precast concrete bridge deck panel system.” *ACI Structural Journal*, 104 (3), 324–332.

Jargeas, G. and Van der Put, J. (2001). “Benefits of Constructability on construction projects.” *J. of Constr. Engrg. and Mgmt.*, ASCE, 127(4), 281-290.

Juntunen, D. (2008). “Conditions and needs of Michigan’s bridges.” *Proc., Bridge operations*, Michigan Department of Transportation, Lansing, MI.

Kendall, A., Keoleian, G.A., and Helfand, G.E. (2008). “Integrated life-cycle assessment and life-cycle cost analysis model for concrete bridge deck applications.” *J. of Infrastructure Systems*, ASCE, 14(3), 214–222.

Khaleghi, B. (2011). “Highways for Life Demonstration Projects and Accelerated Bridge Construction in Washington State.” *Proc., Western Bridge Engineers Seminar*, Session 5B, Phoenix, AZ.

Klaiber, W., Wipf, T., and Wineland V. (2009). *Precast concrete elements for accelerated bridge construction: Laboratory testing, field testing, and evaluation of a precast concrete bridge, Black Hawk County*, Report TR-561, Vol. 3, Iowa State University and Iowa Department of Transportation, Ames, IA.

Larson, C. D., and Forman, E. H. (2007). "Application of Analytical Hierarchy Process to Select Project Scope for Videologging and Pavement Condition Data Collection." *Transportation Research Record: Journal of the Transportation Research Board*, Washington, D.C., 1990, 40–47.

Lavallee, R., and Cadman, K. (2001). "New England Bulb-tee girder brings strength, elegance, and economy to jetport interchange bridge." *PCI journal*, Nov-Dec, 68–75.

LaViolette M. D. (2010). *Design for Modular Bridge on US 6 over Keg Creek in Pottawattamie County, Iowa*, Design Sheets, Project No. BRF-006-1(114)-38-78, Iowa Department of Transportation – Highway Division, Ames, IA.

Li, Y.E. (2010). *Bridge system with precast concrete double-T girder and external unbounded post-tensioning*, Thesis, University of Toronto, Toronto, ON, Canada.

Liang, R., Pensomboon, G. (2010). "Multicriteria Decision Making Approach for highway slope Hazard Management." *Journal of Infrastructure systems*, 16(1), 50–57.

Lee, E.B., Kim, C., and Harvey, J.T. (2011). "Pavement type selection for highway rehabilitation based on a life-cycle cost analysis: Validation of California Interstate 710 Project (phase 1)." *Proc., 90th Annual Meeting of Transportation Research Board*, Washington, D.C., 11-1127.

LoBuono, Armstrong and Associates (1996). *Development of precast bridge substructures*, Final Report, Florida Department of Transportation, Tallahassee, FL.

Lwin, M. (2003). "Removing Existing Segmental Concrete Bridges." Bridge Technology, Federal Highway Administration.
<<http://www.fhwa.dot.gov/bridge/segmental/task210.htm>>(Jun. 28, 2012).

Markowski, S.M. (2005). *Experimental and analytical study of full-depth precast/prestressed concrete deck panels for highway bridges*, Master's Thesis, University of Wisconsin, Madison, WI.

MassDOT (2011). "MassDOT's Fast 14 I-93 Rapid Bridge Replacement Project." *Proc., NHI Innovations Webinar*, Massachusetts Department of Transportation (MassDOT) and National Highway Institute (NHI), Arlington, VA.

Matsumoto, E.E., Waggoner, M.C., Sumen, G., Kreger, M.E., Wood, S.L., and Breen, J.E. (2001). *Development of a Precast Bent Cap System*, Report FHWA/TX-0-1748-2, Center for Transportation Research, University of Texas at Austin, Austin, TX.

Matt, J.R., Wipf, T.J., Phares, B., Fanous, F., and Berg, O. (2011). *Design, Construction, and Field Testing of an Ultra High Performance Concrete Pi-Girder Bridge*, Report TR-574, Iowa State University and Iowa Department of Transportation, Ames, IA.

MCGI. (2009). "Michigan 2009 – Annual Average 24–Hour Traffic Volumes – Map." *Michigan Center for Geographic Information (MCGI), Michigan Department of Transportation and U.S. Department of Transportation, 2009 Average Daily Traffic Maps*, <http://www.michigan.gov/mdot/0,1607,7-151-9622_11033-22141-,00.html> (Feb. 02, 2011)

McMinimee, J.C., Lindsey, S., Hsiao, D., Tang, B.M., Huie, M.F., Baker, M., and Wadsworth, R.L. (2008). "I-215; 4500 South Structure Project Lessons Learned." *Utah Department of Transportation*, Salt Lake City, Utah.

MDOT-BDM. (2013). *Michigan Bridge Design Manual (BDM)*, 5th Ed., Michigan Department of Transportation (MDOT), Lansing, MI.
<<http://mdotwas1.mdot.state.mi.us/public/design/englishbridgemanual/>>

MDOT (2007). *State Long-Range Transportation Plan 2005 – 2030*, Michigan Department of Transportation, Lansing, MI.

MDOT. (2012). *Standard Specifications for Construction*, Michigan Department of Transportation, Lansing, MI.

Mills, D., Chow, K.T., and Marshall, S.L. (1991). "Design-construction of Esker overhead." *PCI Journal*, Sept.-Oct., 44–51.

Moghadam, M.K., Bonsall, S., Wang, J., Wall, A. (2009). "Application of Multiple Attribute decision making and Analytical hierarchy process methods in selection decisions for a container yard operating system." *Marine technology society journal*, Washington, D.C., 43(3), 34–50.

Morcous, G., Hanna, K., and Tadros, M.K. (2011). *Impact of 0.7 inch diameter strands on NU I-girders*, Report SPR-1(08) P311, Nebraska Department of Roads, Omaha, Nebraska.

Moyer, P. (2011). "I-93 FAST 14 project issues & lessons learned – Designer's perspective." *Proc., WHITE Kiewit Joint Venture*, MA.

Murphy, M.L., Kim, J., Sang, Z. and Xiao, C. (2010). *Determining more effective approaches for grouting shear keys of adjacent box beams*, Report FHWA-PA-2010-0140PSU 014, Pennsylvania Department of Transportation, Bureau of planning and research, Harrisburg, PA.

NYDOT. (2012). "Batchellerville bridge replacement project – Project history." *New York State Department of Transportation (NYDOT)*, <<https://www.dot.ny.gov/regional-offices/region1/projects/batchellerville-bridge/history>> (Mar. 31, 2012)

- O'Connor, J.T., and Miller, S.J. (1994). "Barriers to constructability implementation." *J. of the Perform. of Constr. Facil.*, ASCE, 8(2), 110-128.
- Oesterle, R. G., and El-Remaily, A. F. (2009). *Guidelines for Design and Construction of Decked Precast, Prestressed Concrete Girder Bridges*, Final Report, NCHRP Project No. 12-69, National Cooperative Highway Research Program, Transportation Research Board, National Research Council, Washington, D.C.
- Oliva, M.G., Bank, L.C., and Russell, J.S. (2007). *Full Depth Precast Concrete Highway Bridge Decks*, Final Report, Contract Number: 0607-48-01, Wisconsin Department of Transportation, Innovative Bridge Research and Construction, WisDOT, Madison, WI.
- Pate, E.C. (2008). *Analysis of the Inverset(TM) method and the consideration of construction staging stresses in baseline bridge models*, Master's Thesis, Tufts University, ProQuest Information and Learning Company, Ann Arbor, MI,
- PCCPT. (2004). "Concrete paving workforce reference no.1 – Concrete materials storage, mixing and delivery." *Center for Portland Cement Concrete Pavement Technology (PCCPT)*, Iowa State University, Ames, IA.
- PCI. (1976). "T.Y.Lin symposium on prestressed concrete – past, present, future." *Prestressed Concrete Institute (PCI) Journal*, Sept.-Oct., 21(5).
- PCI. (2011). *Chapter 16 – Additional Bridge Products*, Precast/Prestressed Concrete Institute Bridge Design Manual (PCI-BDM), Chicago, IL, <<http://www.pci.org/publications/bridge/index.cfm>>
- PCI Committee (1983). "Fabrication and shipment cracks in prestressed hollow-core slabs and double-tees." *Prestressed Concrete Institute (PCI) Journal*, Jan.-Feb., 28(1), 1–24.
- PCI-NER. (2001). *Precast deck panel guidelines*, Report PCINER-01-PDPG, Precast/Prestressed Concrete Institute-New England Region (PCI-NER), Belmont, MA.
- PCI NE (2011). "Bridge Resources." *Precast/Prestressed Concrete Institute Northeast (PCI NE)*, <www.pcine.org>(Jun. 28, 2012).
- PCSB. (2011). "Precast Prestressed Beams manufactured by us." *Prestasi Concrete Sdn Bhd (PCSB)*, <<http://www.prestasi-concrete.com/product.htm>> (Oct. 25, 2011)
- PennDOT. (1997). *INVERSESET bridge deck evaluation*, Report FHWA-PA-97-003+92-056, Pennsylvania Department of Transportation (PennDOT) & Federal Highway Administration, Penn.
- Perry, V., Dykstra, D., Murray, P., and Rajlic, B. (2010). "Innovative Field Cast UHPC Joints for Precast Bridge Systems - 3-span Live Load Continuous)." *Proc., Bridges - Adjusting to New Realities (A) Session*, Transportation Association of Canada, Halifax, Nova Scotia.

Peterson, K., and Ralls, M.L. (2008). “Accelerated bridge construction (ABC) and the Utah experience.” *Proc., AASHTO Subcommittee on Construction Annual Meeting*, San Antonio, TX.

Qu, S. (2010). *Demolish-IT: the development of a process management tool for the demolition industry*, PhD thesis, Civil and Building Engineering, Loughborough University, England.

Ralls, M.L., Hyzack, M., Medlock, R.D. and Wolf, L.M. (2004). “Prefabricated–Bridges Current U.S. Practice and Issues.” *Proc., FHWA/AASHTO Second National Prefabricated Bridge Elements & Systems Workshop*, Federal Highway Administration (FHWA), New Brunswick, NJ.

Ralls, M. (2005). “Framework for Prefabricated Bridge Elements and Systems (PBES) Decision–Making.” *Proc., Transportation Research Board Annual Conference*, Washington, D.C.

Ralls, M.L., Tang, B., Bhide, S., Brecto, B., Calvert, E., Capers, H., Dorgan, D., Matsumoto, E., Napier, C., Nickas, W., Russell, H. (2005). *Prefabricated bridge elements and systems in Japan and Europe*, Report PI–05–003, Federal Highway Administration and American Association of state highway and transportation officials, Washington, D.C.

Ralls, M.L. (2008). “Accelerated Bridge Design and Construction around the Country.” *Proc., 15th Annual Caltrans/PCMAC Bridge Seminar*, Sacramento, CA.

Rangaraju, P.R., Amirkhani, S., and Guven, Z. (2008). *Life cycle cost analysis for pavement type selection*, Report FHWA-SC-08-01, South Carolina Department of Transportation & Federal Highway Administration, Clemson, SC.

Rao, C., Tajirian, A., and Stubstad, R. (2003). “Lessons learned from the Tappan Zee bridge – New York.” *Division of Engineering Services, Caltrans*, Sacramento, CA.

Reasch, L., Bowden, W., Wells, E. (2010). “Collaboration using the CM/GC Process to Find Solutions for Accelerated Bridge Construction.” *UDOT*, <www.udot.utah.gov/main/uconowner.gf?n=15841921001984906> (Apr. 12, 2011).

Restrepo, J.I., Tobolski, M.J., and Matsumoto, E.E. (2011). *Development of a precast bent cap system for seismic regions*, Report NCHRP-681, National Cooperative Highway Research Program (NCHRP) Report, Transportation Research Board, Washington, D.C.

Richardson, M.W., Scott, D.L., and Tremblay, J.A. (2009). “Concrete bridges in New Hampshire.” *ASPIRE*, Winter, 48–50.

Rister, B.W., and Graves, C. (2002). *The cost of construction delays and traffic control for life-cycle cost analysis of pavements*, Report KTC-02-07/SPR 197-99 & SPR218-00-1F, University of Kentucky and Kentucky Transportation Center, Lexington, Kentucky.

RTA (2004). "Bridge Aesthetics – Design guidelines to improve the appearance of bridges in NSW." *Roads and traffic Authority*, 04(003).

Russell, J.S., Swiggum, K.E, Shapiro, J.M., and Alaydrus, A.F. (1994). "Constructability related to TQM, value engineering, and cost/benefits." *J. of the Perform. of Constr. Facil.*, ASCE, 8(1), 31-45.

Russell, H.G., Volz, J.S., and Bruce, R.N. (1997). "Optimized sections for high-strength concrete bridges." *Report: Federal Highway Administration (FHWA)*, No. FHWA-RD-95-180.

Russell, H. G. (2009). *Adjacent Precast Concrete Box Beam Bridges: Connection Details*, NCHRP Synthesis 393, Transportation Research Board, Washington D.C.

Saaty, T. L. (1980). *The Analytical Hierarchy Process*, McGraw Hill, New York, NY.

Saaty, T. L. (1995). *Decision Making for Leaders – The Analytic Hierarchy Process for Decisions in a Complex World*, RWS Publications, Pittsburgh, PA.

Salem, S., Miller, R. (2006). *Accelerated Construction Decision Making Process for Bridges*, Final report, Midwest Regional University Transportation Center, Research and Special Programs Administration, U.S. Department of Transportation, Washington, D.C.

Scholz, D. P., Wallenfelsz, J. A., Lijeron, C., and Roberts-Wollmann, C. L. (2007). *Recommendations for the Connection Between Full-Depth Precast Bridge Deck Panel Systems and Precast I-Beams*, Final Contract Report, FHWA/VTRC 07-CR17, Virginia Transportation Research Council, Charlottesville, VA.

Seguirant, S.J. (1998). "New deep WSDOT standard sections extend spans of prestressed concrete girders." *PCI Journal*, July-Aug., 92–105.

Shahawy, M.A. (2003). *Prefabricated Bridge Elements and Systems to Limit Traffic Disruption during Construction*, Report NCHRP Synthesis 324, National Cooperative Highway Research Program (NCHRP), Transportation Research Board, Washington, D.C.

Shah, B.N., Tu, S., Sennah, K.M., Kianoush, M.R., and Lam, C. (2006). "Flange-to-flange moment connections for precast concrete deck bulb-tee bridge girders." *PCI Journal*, Nov.-Dec., 2–23.

SHRP 2 (2012). *Innovative Bridge Designs for Rapid Renewal*. SHRP 2 Project R04 Prepublication Draft, Transportation Research Board of the National Academies, Washington, D.C.

Shutt, C.A. (2009). "UHPC provides new solution – New York State's first application of deck bulb-tee girders results from new joint design." *ASPIRE*, Fall, 28–31.

Singh, S., Mirzakashani, M., Hagh, A. (2008). “Demolition of the Grace Memorial and Silas N. Pearman Bridges over Cooper River, South Carolina, USA – A Case Study.” *Structures 2008: Crossing Borders*. ASCE. April.

Smith-pardo, J.P., Ramirez, A. J. (2003). *An Investigation on transversely prestressed Concrete Bridge Decks*, Report FHWA/IN/JTRP/26, Indiana Department of Transportation and Purdue University, West Lafayette, Indiana.

Stamnas, P. E. and Whittemore, M. D. (2005). “All-precaster substructure accelerates construction of prestressed concrete bridge in New Hampshire.” *PCI Journal*, May-June, 26–39.

Starmer, C. F., and Witte, S. (2006). “Changing the face of Charleston: The unbuilding of the Grace and Pearman Bridges.” *Oldcooperriverbridge.org*, <http://oldcooperriverbridge.org/wrapper.php?feb_22_2006_pearman_mainspan.html> (Aug. 23, 2011).

Sullivan, S.R. (2003). *Behavior of transverse joints in precast deck panel systems*, Master’s Thesis, Fritz Dolores H. Russ College of Engineering and Technology, Ohio University, Ohio.

Tadros, M.K., and Morcou, G. (2009). *Application of Ultra-High Performance Concrete to Bridge Girders*, Final Report, Project P310, University of Nebraska-Lincoln and Nebraska Department of Roads, Lincoln, NE.

Tam, C. M., Tong, T. K. L., Chiu, G. W. C. (2006). “Comparing non-structural fuzzy decision support system and analytical hierarchy process in decision making for construction problems.” *European journal of operational research*, 174, 1317–1324.

TFHRC. (2006). *Optimized sections for high-strength concrete bridge girders – effect of deck concrete strength*, Report FHWA-HRT-05-058, Turner-Fairbank Highway Research Center (TFHRC), Federal Highway Administration (FHWA), McLean, VA.

Thoft-Christensen, P. (2007). “Life-cycle cost-benefit (LCCB) analysis of bridges from a user and social point of view.” *Taylor & Francis group – Structure and Infrastructure Engineering Journal*, Aalborg, Denmark, 5(1).

TIC. (2006). *Work Zone Safety – guidelines for construction, maintenance, and utility operations*, Transportation Information Center (TIC), University of Wisconsin, Madison, WI.

Tozier Ltd. (2011). “What rusts, to not rust? Weathering steel does.” *Corten Steel*, <<http://www.tozier2010.com/?p=314>> (Mar. 21, 2012).

Transportation Research Board (1991). *Removing Concrete from Bridges*, National Research Council, Washington, D.C.

UDOT. (2010a). “Utah ABC decision-making process.” *Proc., Utah Department of Transportation (UDOT)*, Salt Lake City, Utah.

UDOT. (2010b). "Bridge Design and Detailing Manuals – UDOT." *Utah Department of Transportation (UDOT)*,

<<http://www.udot.utah.gov/main/uconowner.gf?n=5140612237176152>>

<<http://www.udot.utah.gov/main/uconowner.gf?n=4947119670910725>>

<<http://www.udot.utah.gov/main//f?p=100:pg:0:::1:T,V:2394>>(Apr. 4, 2012).

Uhlik, F.T., and Lores, G.V. (1998). "Assessment of constructability practices among general contractors." *J. of Arch. Engrg.*, ASCE, 4(3), 113-123.

Ulku, E., Attanayake, U., and Aktan, H. M. (2010). "Rationally Designed Staged Posttension Abates Reflective Cracking on Side-by-Side Box-Beam Bridge Decks." *Transportation Research Record: Journal of the Transportation Research Board*, Washington, D.C., 2172, 87-95.

Ulku, E., Attanayake, U., and Aktan, H. M. (2011). "Guidelines for Spacing of Posttension Ducts in Full-Depth Deck Panels." *Proc., 90th TRB Annual Meeting (CD ROM)*, Washington, D.C., 11-2666.

Unlu, D. (2010). *Rapid Bridge Construction Technology: Precast Elements for Substructures*, Master's Thesis, University of Wisconsin-Madison, WI.

Vadivelu, J. (2009). *Impact of larger diameter strands on AASHTO/PCI bulb-tees*, Masters Thesis, University of Tennessee, Knoxville, TN.

Vermont AOT (2011). "High performance concrete, Class AA low cement." *Vermont Agency of Transportation (AOT)*,

<<http://www.aot.state.vt.us/conadmin/Documents/Section%20900%20Items/HIGHPERFORMANCECONCRETECLASSAALOWCEMENT.pdf>> (Feb. 15, 2012).

Versace, J.D., and Ramirez, J.A. (2004). *Implementation of full-width bridge deck panels*, Report FHWA/IN/JTRP-2003/24, Federal Highway Administration, Indiana Department of Transportation and Purdue University, West Lafayette, IN.

Walls, J. and Smith, M.R. (1998). *Life-Cycle Cost Analysis in Pavement Design – Interim Technical Bulletin*, Report FHWA-SA-98-079, Federal Highway Administration, Washington, D.C.

Wiegmann, J., and Sundararajan, A. (2011). *Decision Making for Outsourcing and Privatization of Vehicle and Equipment Fleet Maintenance*, Report NCHRP 692, National Cooperative Highway Research Program (NCHRP) and Transportation Research Board, Washington, D.C.

Winkler, P. (2005). "ICRI Introduces Hydrodemolition Technical Guideline." *Concrete Repair Bulletin*, January/February 2005, 20-21.

Wipf, T.J., Klaiber, W.F., and Hockerman, S. (2009a). *Precast Concrete Elements for Accelerated Bridge Construction: Laboratory Testing of Precast Substructure Components*,

Boone County Bridge, Report TR-561(1-1), Iowa State University and Iowa Department of Transportation, Ames, IA.

Wipf, T.J., Klaiber, W.F., Phares, B., and Bowers, R.P. (2009b). *Precast Concrete Elements for Accelerated Bridge Construction: Laboratory Testing of Full-Depth Precast, Prestressed concrete Deck Panels, Boone County Bridge*, Report TR-561(1-2), Iowa State University and Iowa Department of Transportation, Ames, IA.

Wipf, T.J., Klaiber, W.F., Phares, B., and Becker, M. (2009c). *Precast Concrete Elements for Accelerated Bridge Construction: Field Testing of a Precast Concrete Bridge, Boone County Bridge*, Report TR-561(1-3), Iowa State University and Iowa Department of Transportation, Ames, IA.