



INVESTIGATE CAUSES & DEVELOP  
METHODS TO MINIMIZE EARLY-AGE DECK  
CRACKING ON MICHIGAN BRIDGE DECKS

DECEMBER 2003

**Center for Structural Durability**  
A Michigan DOT Center of Excellence

**WAYNE STATE  
UNIVERSITY**

**RESEARCH**

This report presents the results of research conducted by the authors and does not necessarily reflect the views of the Michigan Department of Transportation. This report does not constitute a standard or specification.

## Technical Report Documentation Page

1. Report No. Research Report RC-1437	2. Government Accession No.	3. MDOT Project Manager Roger D. Till, P.E.	
4. Title and Subtitle Investigate Causes & Develop Methods to Minimize Early-Age Deck Cracking on Michigan Bridge Decks		5. Report Date December 2003	
7. Author(s) Dr. Haluk Aktan, Ph.D, P.E, Dr. Gongkang Fu, Ph.D, P.E, Dr. Waseem Dekelbab, Ph.D, Mr. Upul Attanayaka.		6. Performing Organization Code WSU	
9. Performing Organization Name and Address Department of Civil & Environmental Engineering College of Engineering Wayne State University 5050 Anthony Wayne Drive Detroit, MI 48202		8. Performing Org Report No. CSD-2003-02	
12. Sponsoring Agency Name and Address  Michigan Department of Transportation Construction and Technology Division P.O. Box 30049 Lansing, MI 48909		10. Work Unit No. (TRAIS)	
		11. Contract Number: 2002-0223	
		11(a). Authorization Number:	
15. Supplementary Notes		13. Type of Report & Period Covered Final 01/2002-12/2003	
		14. Sponsoring Agency Code	
16. Abstract  The research identified the major parameters influencing the concrete transverse deck cracking and made recommendations to modify these parameters in order to minimize deck cracking. The synthesis of the data collected revealed that the tensile stress due to early-age thermal load alone could cause deck cracking. Volume change of concrete due to temperature and shrinkage occurs simultaneously. An increase in drying shrinkage arising from delays in concrete placement and wet curing also affect the deck cracking. Additionally, drying shrinkage, beyond the very early ages, increases the crack widths that have previously formed due to thermal loads. Concrete parameters influencing the thermal load levels are: cement type, content, and fineness, ambient temperature at the time of concrete placement, and the time of inception of curing. An important recommendation of this study is the implementation of measures to control and manage thermal and shrinkage stresses in RC decks. The first conclusion is related to current practice. If the curing related stipulations of the Michigan Department of Transportation - Standard Specifications for Construction is strictly adhered to, the density of transverse deck cracks will be reduced. This research established that approximately a 20 °F of thermal load initiates deck cracking. Second, in order to reduce transverse cracking, the primary recommendation is to develop and optimize project specific mix design for the minimization of thermal load. Additional recommendations include the reduction and/or substitution of cement with mineral admixtures and use of current and forecast weather data in optimizing the mix design and placement time in order to minimize the thermal loads.			
17. Key Words Bridge deck, early-age concrete, reinforced concrete, shrinkage effect, thermal effect, transverse cracking		18. Distribution Statement No restrictions. This document is available to the public through the Michigan Department of Transportation.	
19. Security Classification (report) Unclassified	20. Security Classification (Page) Unclassified	21. No of Pages	22. Price



# INVESTIGATE CAUSES & DEVELOP METHODS TO MINIMIZE EARLY-AGE DECK CRACKING ON MICHIGAN BRIDGE DECKS

Submitted to the  
**RESEARCH ADVISORY PANEL**



Submitted by the  
**CENTER FOR STRUCTURAL DURABILITY**  
A Michigan DOT Center of Excellence



Civil And Environmental Engineering Department  
5050 Anthony Wayne Dr.  
Detroit, MI 48202

Dr. Haluk Aktan, P.E.  
Professor  
[Haluk.Aktan@wayne.edu](mailto:Haluk.Aktan@wayne.edu)  
Tel: 313-577-3825  
Fax: 313-577-9850

Mr. Upul Attanayaka  
Graduate Research Assistant  
[upul@wayne.edu](mailto:upul@wayne.edu)  
Tel: 313-577-9293  
Fax: 313-577-9850

Dr. Gongkang Fu, P.E.  
Professor  
[Gfu@ce.eng.wayne.edu](mailto:Gfu@ce.eng.wayne.edu)  
Tel: 313-577-3842  
Fax: 313-577-3881

Dr. Waseem Dekelbab  
Research Associate  
[W\\_Dekelbab@wayne.edu](mailto:W_Dekelbab@wayne.edu)  
Fax: 313-577-3881

**DECEMBER 2003**



## EXECUTIVE SUMMARY

The need for this research was based on an observed deck deterioration mechanism that is accelerated by the existence of cracks. The primary objective of this research was to identify the major parameters influencing concrete deck cracking. The second objective was to develop recommendations for the modification of these parameters that are within the control of the bridge designer, the materials engineer, the contractor, and/or the maintenance engineer. The project tasks consisted of literature review, nationwide survey on the subject of reinforced concrete (RC) deck cracking, field inspection and data collection of existing RC bridge decks of age five years or less, construction monitoring of new decks, laboratory and field testing, and data analysis and synthesis.

The literature review revealed that early-age cracking is the single most prevalent deck distress reported by all of the State Highway Agencies. Although there have been many studies performed with regard to the cause of early-age deck cracking, the problem still persists. Synthesis of the literature indicated that the restrained thermal and shrinkage effects coupled with construction practices are the main parameters influencing deck cracking.

The information extracted from the nationwide survey regarding the experience of other states with the problem of early-age deck cracking was also compared; specifically, with the states of the Central North East Region (Illinois, Minnesota, New York, Pennsylvania, and Wisconsin) with a similar climatic exposure to that of Michigan. All of these states indicated that they observe early-age cracking on concrete bridge decks and the prevalent type is transverse cracking. In order to control deck cracking, the most popular measures taken by these states are: use of mineral admixtures, and changes to mix design and curing procedure. Illinois, New York, and Pennsylvania started adding fly ash, silica fume, and ground granulated blast-furnace slag as mineral additives in their mix design, whereas Wisconsin has been adding fly ash and ground granulated blast-furnace slag. New York, Minnesota, and Wisconsin are using retarder, air entrainer, and mid-range water reducer admixtures, but Illinois and Pennsylvania are using only air entrainer in their concrete mix design. The most often specified deck thickness among the states is 8 inches, but Minnesota utilizes a 9-inch deck. The common curing practice among

these states is continuous wet curing with the exception of Illinois. The top three causes of cracking identified by the respondents from these States are substandard curing, construction practice, and mix design. These top three causes of cracking matches with Michigan's responses. Illinois and Minnesota use a reduced cement content of 6 sacks/yd<sup>3</sup>.

The field inspection data analysis of twenty bridges indicated that crack density is higher on continuous bridges than on simple span bridges. Transverse and diagonal crack densities are higher on side-by-side box-beam bridges than on other girder types. Bridges with PCI girders show minimum longitudinal crack density compared with other bridge girder types (i.e., steel, side-by-side box-beam, and spread box-beam). However, there is no clear relationship between deck crack density and bridge skew, deck thickness, span length, or ADTT.

During construction monitoring, observed curing procedures were often in conflict with the Michigan Department of Transportation-Standard Specifications for Construction. A Standard Specification requirement, which states that no more than 10 feet of textured concrete surface should be left exposed without curing compound at any time, was never observed. In two of the five deck placement projects, curing compound was applied upon the placement of the full deck. In the Standards Specifications for Construction, wet curing requires covering concrete with clean, contaminant-free wet burlap as soon as the curing compound is sufficiently dried and the concrete surface is sufficiently hardened. Again, according to the Specifications, wet curing should commence within two hours upon concrete placement. In all five of the deck replacement projects monitored, the burlap when first placed was never wet and was placed after 12 to 36 hours upon concrete placement.

Laboratory tests on concrete samples taken during construction monitoring indicate that out of the five bridges monitored, three had a deck concrete 28-day compressive strength in excess of 6000 psi. Concrete with a 28-day compressive strength greater than 6000 psi is classified as high-strength concrete and needs to comply with special construction and curing procedures. The laboratory tests also showed that the gain in compressive strength and elasticity modulus from 3 to 7 days were rapid, indicating high early strength concrete properties. Concrete with such properties generates high thermal loads during hydration and high drying shrinkage during early ages. Consequently, increased deck cracking should be expected.



The synthesis of all the data collected revealed that the tensile stresses due to early-age thermal load alone could cause deck cracking. Volume change of concrete under thermal and shrinkage effects occur simultaneously. An increase in drying shrinkage from delays in wet curing will increase tensile stresses. Drying shrinkage, upon curing, will increase crack width that have formed under thermal loads. For a fixed mix design, the ambient temperature at the time of concrete placement governs the early-age concrete thermal properties. Concrete mix parameters controlling the thermal load are the cement type, content, and fineness, and the time of inception of curing. The temperature difference between the peak temperature during hydration and the ambient temperature establishes the thermal load on the deck concrete. The thermal load controls the magnitude of the tensile stresses that develops in the deck. Use of retarders in the concrete mix delays the hydration process and may be an advantage or a drawback depending on the ambient temperature at the time of peak hydration temperature.

The first conclusion of this study is related to current practice. If the curing related stipulations of the Michigan Department of Transportation - Standard Specifications for Construction is strictly adhered to, the density of transverse deck cracks will be reduced. This research established that approximately a 20<sup>0</sup> F of thermal load initiates deck cracking. Second, in order to reduce transverse cracking, the primary recommendation is to develop and optimize project specific mix design for the minimization of thermal load. As an incentive for developing a project specific mix design, peak concrete temperature during hydration may be defined as a performance parameter. The limits to the hydration temperature may be specified in the Standard Specifications. Inclusion of concrete hydration temperature in the specifications is feasible since it is measurable and with certain limitations (cement mill properties) is within the control of the contractor by the concrete mix design and curing.

This study recommends a continuation research project for development of mix parameters that are optimized for the reduction of thermal and shrinkage loads. The proposed research should also include the development of tools that will utilize the current and forecasted climatic data as well as cement and aggregate properties in order to determine an optimized project specific mix design.



## **ACKNOWLEDGMENTS**

The funding of this study was provided by the Michigan Department of Transportation through the Center for Structural Durability at Wayne State University. The authors would like to acknowledge the support of the Project Manager, Roger D. Till, for initiating this research and his effort during its conduct. The authors also wish to acknowledge the continuing assistance of the Research Advisory Panel (RAP) members in contributing to the advancement of this study. The kind help provided by Neil Pullman, Steve Kahl, and Tom Tellier during the field inspections is gratefully acknowledged.

The authors acknowledge the support and efforts of Dr. Recep Birgul for his work on this project. We would also like to thank Upendra Poudel, Jian Ye, Jihang Feng, Reynaldo Pablo, Okan Duyar, Yilmaz Koyuncu, Rudaba Chowdhury, Jason Rutyna, and Carissa Markel for their assistance during inspection, construction monitoring, and sample preparation. Assistance of Carrie Saul and Bonnie Yu in the preparation of the final and quarterly reports is much appreciated.

We appreciate the help of deck contractors in providing the concrete materials for this study. Our special thank to Michigan Foundation Concrete for providing cement mill reports for the cement used in the majority of the concrete mixes this study dealt with.



# TABLE OF CONTENTS

<b>EXECUTIVE SUMMARY .....</b>	<b>i</b>
<b>ACKNOWLEDGMENTS .....</b>	<b>v</b>
<b>LIST OF FIGURES .....</b>	<b>xi</b>
<b>LIST OF TABLES .....</b>	<b>xvi</b>
<b>LIST OF PHOTOGRAPHS.....</b>	<b>xviii</b>
<b>1 Introduction .....</b>	<b>1</b>
<b>2 State-of-the-Art Literature Review .....</b>	<b>4</b>
2.1 Introduction.....	4
2.2 Material Related Issues.....	4
2.2.1 Concrete Constituent Materials and Selection Criteria.....	10
2.3 Design Related Issues .....	30
2.4 Environmental or Site Conditions .....	31
2.4.1 Evaporation of Water from Fresh Concrete.....	33
2.5 Construction Related Factors.....	34
2.6 Temperature and Thermal Stress Development .....	35
2.6.1 Overview.....	35
2.6.2 Hydration Temperature Stresses.....	35
2.6.3 Diurnal Temperature Stresses.....	42
2.6.4 Seasonal Temperatures Stresses .....	43
2.6.5 Summary of Factors Affecting Thermal Stresses and Precautions.....	43
2.7 Shrinkage Effects on Deck Cracking .....	44
2.7.1 Overview.....	44
2.7.2 Factors Affecting Shrinkage .....	45
2.8 Analysis of Crack Formation.....	50
2.9 Conclusions and the Need for Future Research .....	52
<b>3 Multi-State Survey .....</b>	<b>54</b>

3.1	Overview.....	54
3.2	Analysis of Survey Data.....	56
3.3	Conclusion.....	67
<b>4</b>	<b>Field Inspection and Data Analyses .....</b>	<b>70</b>
4.1	Field Inspection .....	70
4.2	Inspection Data Processing Steps.....	74
4.3	Bridge Geometry and Design Effect on Deck Cracking .....	78
4.3.1	Longitudinal Cracks and Controlling Factors.....	78
4.3.2	Transverse and Diagonal Cracks and Controlling Factors .....	81
4.3.3	Map Cracks and Controlling Factors .....	85
4.3.4	ADTT Effect on Bridge Deck Cracking.....	87
4.4	Conclusions.....	89
<b>5</b>	<b>Construction Monitoring.....</b>	<b>90</b>
5.1	Overview.....	90
5.2	Concrete Mix Design, Fresh Concrete Properties, and Ambient Environmental Conditions .....	91
5.3	Specification Requirements and Field Observations.....	92
5.3.1	Formwork.....	92
5.3.2	Placement of Steel Reinforcements .....	92
5.3.3	Concrete Placement .....	93
5.3.4	Vibration of Fresh Concrete.....	95
5.3.5	Nighttime Casting of Superstructure Concrete.....	96
5.3.6	Finishing of Plastic Concrete.....	97
5.3.7	Texturing.....	97
5.3.8	Curing of the Deck Concrete .....	99
5.3.9	Additional Observations .....	102
5.4	Visual Representation of the Deck Casting Process .....	103
5.4.1	Bridge ID S06 of 82194.....	103

5.4.2	Bridge ID S26 of 50111 .....	113
5.4.3	Bridge ID S05 of 82191 .....	123
5.4.4	Bridge ID S05 of 82025 .....	131
5.4.5	Summary of Construction Monitoring Data .....	141
5.5	Post-Construction Monitoring of Bridge Decks.....	144
5.6	Conclusions.....	145
<b>6</b>	<b>Field and Laboratory Testing .....</b>	<b>148</b>
6.1	Overview.....	148
6.1.1	Samples Obtained During Construction Monitoring .....	149
6.1.2	Test Procedures for Samples Obtained During Construction Monitoring.....	150
6.1.3	Test Procedure for Fresh Concrete Properties .....	150
6.2	Test Results.....	151
6.2.1	Fresh Concrete Properties .....	151
6.2.2	Construction Monitoring Samples .....	151
6.3	Conclusions.....	156
<b>7</b>	<b>Parameters Influencing Deck Cracking.....</b>	<b>157</b>
7.1	Overview.....	157
7.2	Prediction Models for Mechanical Properties of Concrete .....	160
7.2.1	Compressive Strength .....	160
7.2.2	Elasticity Modulus .....	163
7.2.3	Direct Tensile Strength .....	166
7.2.4	Concrete Strain.....	166
7.3	Thermal Strains and Stresses .....	167
7.3.1	Overview.....	167
7.3.2	Tensile Stress Development in Decks Under Thermal Loads .....	167
7.3.3	Thermal Stresses on a Typical Michigan Deck .....	169
7.4	Methods for Estimating Shrinkage Strain .....	180
7.4.1	Overview.....	180

7.4.2	Shrinkage and Cracking Relationship.....	186
7.5	Conclusions.....	187
<b>8</b>	<b>Summary &amp; Conclusions.....</b>	<b>189</b>
8.1	Summary.....	189
8.2	Conclusions.....	189
<b>9</b>	<b>Suggestions for Future Research.....</b>	<b>192</b>
<b>10</b>	<b>References .....</b>	<b>193</b>
<b>Appendix A Multi-State Survey Response Data</b>		
<b>Appendix B Field Inspection Data</b>		
<b>Appendix C Construction Monitoring Data Sheets</b>		
<b>Appendix D Schedule for Laboratory Testing</b>		
<b>Appendix E Laboratory Data Sheets</b>		



## LIST OF FIGURES

Figure 2-1. Cracking–tendency test apparatus reported by Krauss and Rogalla (1996) .....	7
Figure 2-2. The most appropriate curing regimes during the course of the hydration reaction ..	21
Figure 2-3. Effect of concrete placing temperature and volume to surface (exposed to environment) ratio on age at peak temperature for Type 1 cement .....	37
Figure 2-4. The effect of volume to surface ratio and age at peak temperature on percent absorbed or dissipated of difference in placing and ambient temperature.....	38
Figure 2-5. Effects of placement temperature on adiabatic temperature rise .....	39
Figure 2-6. The effect of volume to surface ratio and exposed surface condition on temperature rise of concrete members (376 lb/yd <sup>3</sup> ) .....	40
Figure 2-7. Variation of adiabatic temperature rise with age of concrete for different types of cements.....	41
Figure 2-8. Effects of cement fineness on heat generation.....	42
Figure 2-9. (a) Stress-strain envelope for cracking of concrete and (b) stress-normal crack strain after crack initiation (assuming linear-elastic behavior).....	52
Figure 3-1. States who responded to the survey .....	55
Figure 3-2. Frequency of early-age cracking observed on decks .....	56
Figure 3-3. Frequency of cracks observed during different ages of bridge decks.....	57
Figure 3-4. Frequency of crack types observed on bridge decks.....	57
Figure 3-5. Expectations on bridge deck service life.....	58
Figure 3-6. Frequency of expected service life of bridge decks under average traffic.....	58
Figure 3-7. Frequency of different actions taken to improve bridge deck durability .....	59
Figure 3-8. Frequency of using different types of mineral additives in concrete mix.....	60
Figure 3-9. Frequency of using different types of admixtures in concrete mix.....	60
Figure 3-10. Frequency of using different top cover on reinforced concrete decks .....	61
Figure 3-11. Frequency of using different total deck thicknesses for bridge decks .....	61
Figure 3-12. Frequency of using different top cover and total deck thickness in the past .....	62
Figure 3-13. Frequency of using different top cover for bridge decks .....	62
Figure 3-14. Frequency of using different deck thickness in the past .....	63
Figure 3-15. Frequency of using different reinforcement types on bridge decks .....	63

Figure 3-16. Frequency of using different curing methods upon concrete placement .....	64
Figure 3-17. Frequency of using different curing durations .....	64
Figure 3-18. Frequency of top three causes of early-age bridge deck cracking .....	65
Figure 3-19. Frequency of using different amounts of cement in concrete mix .....	66
Figure 3-20. States with similar climatic exposures to Michigan.....	68
Figure 4-1. Deck inspection template example with sample inspection data .....	72
Figure 4-2. Selected photos taken during the deck inspection.....	73
Figure 4-3. Longitudinal crack density histogram (20 Bridges).....	76
Figure 4-4. Transverse crack density histogram (20 Bridges).....	76
Figure 4-5. Diagonal crack density histogram (20 bridges) .....	76
Figure 4-6. Modified longitudinal crack density histogram (17 Bridges) .....	77
Figure 4-7. Modified transverse crack density histogram (19 Bridges) .....	77
Figure 4-8. Beam structural type vs longitudinal crack density .....	78
Figure 4-9. Girder type vs longitudinal crack density .....	78
Figure 4-10. Bridge skew vs longitudinal crack density.....	79
Figure 4-11. Slab thickness vs longitudinal crack density.....	79
Figure 4-12. Year built vs longitudinal crack density.....	79
Figure 4-13. Inspected span length vs longitudinal deck cracking.....	80
Figure 4-14. Structural type vs longitudinal crack density in steel bridges.....	80
Figure 4-15. Girder type vs longitudinal crack density for simple span bridges.....	81
Figure 4-16. Beam structural type vs crack density.....	81
Figure 4-17. Girder type vs crack density.....	82
Figure 4-18. Bridge skew vs deck crack density .....	82
Figure 4-19. Slab thickness vs crack density .....	82
Figure 4-20. Year built vs crack density .....	83
Figure 4-21. Inspected span length vs crack density .....	83
Figure 4-22. Structural type vs crack density in steel bridge.....	84
Figure 4-23. Girder type vs crack density for simple span bridges .....	84
Figure 4-24. Girder type vs crack density for continuous bridges.....	84
Figure 4-25. Beam structural type vs map crack density.....	85

Figure 4-26. Girder type vs map crack density.....	85
Figure 4-27. Bridge skew vs map crack density.....	86
Figure 4-28. Slab thickness vs map crack density.....	86
Figure 4-29. Year built vs map crack density.....	86
Figure 4-30. Inspected span length vs map crack density.....	87
Figure 4-31. Bridge ADTT vs longitudinal crack density.....	88
Figure 4-32. Bridge ADTT vs transverse crack density.....	88
Figure 4-33. Bridge ADTT vs diagonal crack density.....	88
Figure 5-1. S06 of 82194 Concrete placement, time elapsed per yard.....	104
Figure 5-2. S06 of 82194, South section concrete placement time sequence.....	105
Figure 5-3. S06 of 82194, North section concrete placement time sequence.....	105
Figure 5-4. S06 of 82194, Cumulative concrete placed vs time elapsed.....	106
Figure 5-5. S06 of 82194, Time and volume of concrete placed vs truck arrival.....	106
Figure 5-6. S06 of 82194, Concrete finishing, time elapsed per yard.....	107
Figure 5-7. S06 of 82194, South section concrete finishing time sequence.....	108
Figure 5-8. S06 of 82194, North section concrete finishing time sequence.....	108
Figure 5-9. S06 of 82194, Concrete texturing, time elapsed per yard.....	109
Figure 5-10. S06 of 82194, South section concrete texturing time sequence.....	110
Figure 5-11. S06 of 82194, North section concrete texturing time sequence.....	110
Figure 5-12. S06 of 82194, Curing compound application, time elapsed per yard.....	111
Figure 5-13. S06 of 82194, South section curing compound application time sequence.....	112
Figure 5-14. S06 of 82194, North section curing compound application time sequence.....	112
Figure 5-15. S26 of 50111, Concrete placement, time elapsed per yard.....	114
Figure 5-16. S26 of 50111, East section concrete placement time sequence.....	115
Figure 5-17. S26 of 50111, West section concrete placement time sequence.....	115
Figure 5-18. S26 of 50111, Cumulative concrete placed vs time elapsed.....	116
Figure 5-19. S26 of 50111, Time and volume of concrete placed vs truck arrival.....	116
Figure 5-20. S26 of 50111, Concrete finishing, time elapsed per yard.....	117
Figure 5-21. S26 of 50111, East section concrete finishing time sequence.....	118
Figure 5-22. S26 of 50111, West section concrete finishing time sequence.....	118

Figure 5-23. S26 of 50111, Concrete texturing, time elapsed per yard .....	119
Figure 5-24. S26 of 50111, East section concrete texturing time sequence .....	120
Figure 5-25. S26 of 50111, West section concrete texturing time sequence .....	120
Figure 5-26. S26 of 50111, Curing compound application, time elapsed per yard .....	121
Figure 5-27. S26 of 50111, East section curing compound application time sequence .....	122
Figure 5-28. S26 of 50111, West section curing compound application time sequence .....	122
Figure 5-29. S05 of 82191, Concrete placement, time elapsed per yard .....	124
Figure 5-30. S05 of 82191, West section concrete placement time sequence .....	125
Figure 5-31. S05 of 82191, East section concrete placement time sequence .....	125
Figure 5-32. S05 of 82191, Cumulative concrete placed vs time elapsed .....	126
Figure 5-33. S05 of 82191, Time and volume of concrete placed vs truck arrival .....	126
Figure 5-34. S05 of 82191, Concrete finishing, time elapsed per yard .....	127
Figure 5-35. S05 of 82191, West section concrete finishing time sequence .....	128
Figure 5-36. S05 of 82191, East section concrete finishing time sequence .....	128
Figure 5-37. S05 of 82191, Concrete texturing, time elapsed per yard .....	129
Figure 5-38. S06 of 82191, West section concrete texturing time sequence .....	130
Figure 5-39. S05 of 82191, East section concrete texturing time sequence .....	130
Figure 5-40. S05 of 82025, Concrete placement, time elapsed per yard .....	132
Figure 5-41. S05 of 82025, Concrete placement time sequence .....	133
Figure 5-42. S05 of 82025, Cumulative concrete placed vs time elapsed .....	134
Figure 5-43. S05 of 82025, Time and volume of concrete placed vs truck arrival .....	134
Figure 5-44. S05 of 82025, Concrete finishing, time elapsed per yard .....	135
Figure 5-45. S05 of 82025, Concrete finishing time sequence .....	136
Figure 5-46. S05 of 82025, Concrete texturing, time elapsed per yard .....	137
Figure 5-47. S05 of 82025, Concrete texturing time sequence .....	138
Figure 5-48. S05 of 82025, Curing compound application, time elapsed per yard .....	139
Figure 5-49. S05 of 82025, Curing compound application time sequence .....	140
Figure 5-50. Summary of construction monitoring data of bridge S05 of 82025 .....	141
Figure 7-1. Geometry and reinforcement arrangement of the deck section supported on PCI girders .....	158

Figure 7-2. Uniform temperature distribution within the deck.....	159
Figure 7-3. Compressive strength variation against time (S05 of 82191).....	162
Figure 7-4. Compressive strength variation against time (S05 of 82025).....	162
Figure 7-5. Compressive strength variation against time (S06 of 82194).....	163
Figure 7-6. Variation of elasticity modulus against time (S05 of 82191).....	164
Figure 7-7. Variation of elasticity modulus against time (S05 of 82025).....	165
Figure 7-8. The comparison of CRC model predictions and the test data.....	166
Figure 7-9. Compatibility shear force and moment at deck-girder interface.....	173
Figure 7-10. Geometry and reinforcement arrangement of the deck section supported on PC spread box girders .....	178
Figure 7-11. Geometry and reinforcement arrangement of the deck section supported on steel girders.....	178
Figure 7-12. Effects of wet curing duration – shrinkage predicted by ACI model .....	187

## LIST OF TABLES

Table 2-1. Factors Affecting Cracking (Krauss and Rogalla, 1996) .....	8
Table 2-2. Effect of Type of Aggregate on the Drying Shrinkage of Concrete.....	10
Table 2-3. The Cement Types and Properties in ASTM C 150.....	12
Table 2-4. The Cement Types and Properties in ASTM C 595.....	13
Table 2-5. Expansive Type of Cements and their Constituents.....	14
Table 2-6. Types of Admixtures in ASTM C 494 and Definitions .....	22
Table 2-7. The Deck Concrete Design in other States with Similar Exposure to Michigan .....	27
Table 2-8. Cement Types and Fineness used for Developing Graphs in ACI 207.2R .....	41
Table 2-9. Change of Cement Properties and Strength.....	46
Table 3-1. List of Respondent States and Media of Response .....	54
Table 4-1. List of Bridge Decks Inspected .....	71
Table 4-2. Deck Crack Density of the Inspected Bridges and Controlling Parameters.....	75
Table 4-3. ADTT and Crack Density Data for the Inspected Bridges.....	87
Table 5-1. List of Bridges Monitored during Deck Placement.....	90
Table 5-2. Concrete Mix Designs for Bridges Monitored during Deck Placement.....	91
Table 5-3. Fresh Concrete Properties of Bridges Monitored during Deck Placement .....	91
Table 5-4. Temperature & Relative Humidity over Time of Bridges Monitored during Deck Placement .....	92
Table 5-5. Summary of Construction Monitoring Data for Bridge S06 of 82194.....	142
Table 5-6. Summary of Construction Monitoring Data for Bridge S26 of 50111.....	142
Table 5-7. Summary of Construction Monitoring Data for Bridge S05 of 82191.....	143
Table 5-8. Summary of Construction Monitoring Data for Bridge S05 of 82025.....	143
Table 6-1. Tests to be Conducted and the Required Number of Samples .....	149
Table 6-2. Field Tests for Quality Control of Fresh Concrete.....	151
Table 6-3. Compressive Strength Test Results .....	152
Table 6-4. Modulus of Elasticity Test Results.....	152
Table 6-5. Poisson’s Ratio Test Results .....	153
Table 6-6. RCPT Test Results .....	154
Table 6-7. UPV Test Results .....	154

Table 6-8. Air Permeability Test Results.....	155
Table 6-9. Absorption Test Results .....	155
Table 7-1. Ratio of Static to Dynamic Moduli .....	166
Table 7-2. Parameters used for Calculating Peak Differential Temperature in Deck Concrete	170
Table 7-3. Mechanical Properties and Ambient Temperature at the Time of Peak Temperature .....	170
Table 7-4. Differential Deck Temperature for Construction Season and Cement Fineness.....	171
Table 7-5. Stress Developed at the Bottom of the Deck due to Thermal Effects (7 Sacks of Cement).....	175
Table 7-6. Mechanical Properties of Concrete with 6 Sacks of Cement .....	176
Table 7-7. Mechanical Properties of Concrete with 4 Sacks of Cement .....	176
Table 7-8. Stress Developed at the Bottom of the Deck due to Thermal Effects (6 Sacks & 4 Sacks of Cement) .....	177
Table 7-9. Summary of Geometric Properties of Bridge Decks .....	179
Table 7-10. Tensile Stress Developed at Girder-Deck Interface .....	179
Table 7-11. Summary of Geometric Properties of Bridge Decks .....	179
Table 7-12. Tensile Stress Developed at Girder-Deck Interface .....	180
Table 7-13. Limitations of Shrinkage Prediction Models.....	181
Table 7-14. The Relationship Between Humidity Range and Correction Formula.....	182
Table 7-15. Coefficients $\alpha_1$ and $\alpha_2$ used in Bazant B3 Model.....	182
Table 7-16. Cement Type Coefficient used in CEB-FIP 90 Model.....	184
Table 7-17. Cement Type Coefficient used in Gardner-Lockman Model .....	185
Table 7-18. Predicted Shrinkages for Different Curing Periods.....	186

## LIST OF PHOTOGRAPHS

Photo 5-1. Deck reinforcement of I-75 over Fort Street.....	93
Photo 5-2. Concrete placement of I-94 over Quinn road.....	94
Photo 5-3. Concrete placement of Vreeland over I-75 .....	95
Photo 5-4. Vibration of fresh concrete of Vreeland over I-75.....	96
Photo 5-5. Finishing concrete of Vreeland over I-75 .....	97
Photo 5-6. Texturing of concrete of I-75 over Fort Street .....	98
Photo 5-7. Close-up of textured concrete of I-75 over Fort Street .....	99
Photo 5-8. Application of curing compound of I-94 over Quinn road .....	100
Photo 5-9. Diamond ground deck surface of bridge S06 of 82194 .....	102
Photo 5-10. Replaced deck of bridge S06 of 82194 .....	144
Photo 5-11. Observed cracking on replaced deck of bridge S06 of 82194.....	145



# 1 INTRODUCTION

Reinforced concrete (RC) bridge decks are designed and constructed to provide a durable riding surface and at the same time to meet requirements concerned with, for example, safety, geometry, etc. They are subjected to severe and harsh environment in Michigan, such as high live load stresses, alternate wetting and drying, freeze-thaw cycles, severe thermal gradients, effects of deicing salt, etc. The deteriorating actions on RC bridge decks can be categorized into two groups: 1) physical actions generating internal stresses and 2) chemical action of agents penetrating into the deck material and causing deterioration such as steel corrosion. The two categories of action interact, especially when the internal stresses are large enough to cause cracking of the deck concrete. In order to improve bridge deck durability, both structural and material aspects of the problem need to be addressed in a systematic fashion. These aspects are also related to the construction procedure of manufacturing the material and building the structural system. Further, these aspects must be addressed with adequate consideration to the environment to which the deck is to be subjected, including truck wheel loading, thermal effects, freeze-thaw cycles, salt, etc.

RC bridge decks provide a “roof” to the supporting superstructure and substructure. They protect these components of the bridge from being directly exposed to surface runoff, deicing salt, etc. Thus a durable deck often results in a durable bridge which highlights the importance of the deck. It also has been documented that a large percentage of renewal funds for bridges have been spent on bridge decks for patching, overlay, and replacement. Therefore, there is an eminent need for more durable concrete bridge decks. In Michigan, this need is more profound because of the numerous freeze-thaw cycles, large amount of deicing salt usage, and high volumes of heavy trucks.

The primary objective of this research is to identify the major parameters influencing RC bridge deck life in Michigan, particularly those related to concrete cracking. The second objective is to develop recommendations to modify these parameters that are within the control of the bridge designer, materials engineer, the contractor, and/or the maintenance engineer in order to maximize deck life.

In this research project, the following tasks were fulfilled.

Literature review. The review has covered issues of concrete material, structural design, construction procedure, and environmental conditions in relation to RC deck cracking. In addition, the effects of shrinkage and thermal stresses on deck cracking received special attention in the review. The results of this review are documented in Chapter 2 of this report.

Nationwide survey on RC deck cracking. The survey was issued to state departments of transportation around the country. The purpose of the survey were a) to understand the extent of RC deck cracking in the country; b) to gather information on latest research efforts in other states on this subject; and c) to understand the experiences of other states in reducing and minimizing RC deck cracking. The questionnaire and the compiled data are presented in Appendix A. The survey results are presented and analyzed in Chapter 3.

The field inspection of existing RC bridge decks that were replaced within the last 5 years and analysis of the inspection data. This task was to establish the extent of RC deck cracking in Michigan. Data was collected and analyzed to identify factors that may contribute to RC deck cracking. Twenty bridges with RC decks were randomly selected from the population of trunk line bridges. The deck inspection procedure, statistical analysis procedure, and the results are discussed in Chapter 4. The compiled raw data is presented in Appendix B.

Construction monitoring. This task was to observe typical RC deck placement and compare against the Michigan Department of Transportation (MDOT) - Standard Specifications for Construction. Five RC deck placement projects were monitored, including data collection and inspection during concrete placement. Ambient Environmental data, including temperature and humidity, was collected all through the placement of the entire deck. In addition, the concrete placement process was recorded for each truckload. The concrete truck's arrival, placement, finishing, curing compound placement, and wet burlap cover placement times were recorded. The raw time data gathered during construction monitoring is presented in Appendix C. This data helped the researchers to identify violations to the MDOT Standard Specifications for Construction. The discussion of this task is presented in Chapter 5.

Laboratory and Field Testing. This task was to further examine the concrete materials used for placement of decks. The tests were performed on concrete samples prepared from the five concrete deck placement projects. The field testing included measuring slump, concrete temperature, and air content of fresh concrete. In addition, the following tests were conducted in the laboratory to achieve the concrete properties: Compressive Strength, Modulus of Elasticity, Ultrasonic Pulse Velocity (UPV), Permeability, Rapid Chloride Penetration (RCPT), and Absorption tests. This task is summarized in Chapter 6.

Parameters Influencing Deck Cracking. This task was to integrate the data collected in the above tasks in order to establish the parameters that control or influence deck cracking. The structural parameters that establish the influence of girder and reinforcement restraints on the concrete deck leading the crack formation are derived and assessed. This task presented in Chapter 7 focused on the thermal and shrinkage loads as the two factors responsible for the volume change of hardened concrete deck, including analysis for typical bridges.

Summary and Conclusions. Chapter 8 of the report summarizes the findings of the research project and presents recommendations for possible follow-up steps.

Suggestions for further research are given in Chapter 9.

## **2 STATE-OF-THE-ART LITERATURE REVIEW**

### **2.1 INTRODUCTION**

Early-age bridge deck cracking is a problem throughout the United States. Many highway agencies studied and investigated the causes of bridge deck cracking. However, the problem of early-age bridge deck cracking has not been resolved. Many researchers divided the parameters that influence bridge deck cracking into four main categories:

1. Material related issues
2. Design related issues
3. Environmental or site conditions
4. Construction related issues

This chapter is organized in eight sections. Section 2.2 discusses the studies of material effects on early-age bridge deck cracking. Section 2.3 presents the previous studies regarding design related issues. In Section 2.4, the summary and main recommendations from previous studies regarding the environmental related issues are presented. The investigation of construction related issues with regard to deck cracking are explained in Section 2.5. Section 2.6 briefly discusses the effects of temperature and thermal stresses on early-age bridge deck cracking. Effects of shrinkage on deck cracking are explained in Section 2.7. Section 2.8 examines the crack formation phenomenon. Section 2.9 summarizes the major findings and remedial measures taken to minimize early-age bridge deck cracking.

### **2.2 MATERIAL RELATED ISSUES**

Concrete bridge decks develop transverse cracking when longitudinal tensile stresses in the deck exceed the tensile strength of the concrete with sufficient accompanying strain levels. The tensile stresses are caused by the volume change of concrete due to shrinkage and thermal loads, and internal and external restraints. Therefore, many studies are focused on minimization of bridge deck cracking through modifications to construction materials and concrete mix designs.

Dakhil et al., (1975) reported that higher slump concrete and larger reinforcing bars tend to be found in decks observed to be more susceptible to cracking. In contrast, Cheng and Johnston (1985) observed a decrease in transverse cracking in bridge decks with increasing slump. They

also observed reduced cracking with increasing air content. The use of high slump concrete, an excessive amount of water resulting from inadequate mixture proportions, and retempering of concrete causes concrete cracking (Issa 1999).

Purvis et al., (1995) studied premature cracking of concrete bridge decks in three phases. The first phase was the examination of existing bridge decks. This phase included visual walk-by surveys of 111 bridge decks built in Pennsylvania. The bridges selected were built within 5 years of the survey and an in-depth survey was conducted on 12 of the 111 bridge decks. The in-depth surveys included the documentation of crack patterns, crack width, rebar location and depth, and finally concrete coring. The result of this phase indicated that almost all transverse cracks followed the line of the top transverse bars, regardless of the type of superstructure. Coring of concrete showed that transverse crack depth extended to the level of the top transverse bars and beyond. It was also observed that thicker cover depth caused wider cracks because the longitudinal crack control reinforcement is embedded more deeply into the concrete. Examination of concrete cores showed that transverse cracks often intersect coarse aggregate particles. This indicated that the cracks occurred in the hardened concrete as opposed to the plastic concrete. Therefore, the cause of cracking was most likely drying shrinkage and thermal shrinkage, rather than factors such as plastic shrinkage that is caused by surface evaporation prior to curing, or settlement of plastic concrete between the top transverse bars.

The second phase involved the observation of the construction of eight bridge decks to identify procedures contributing to shrinkage and possibly leading to cracking. The third phase involved using laboratory experiments that focused on examining the effects of aggregate, cement, and fly ash on shrinkage. The result of this phase indicated that the main cause of transverse cracking is the shrinkage of hardened concrete. Further, the type of aggregate used in the concrete mix is a major factor associated with shrinkage cracking. Aggregate contributes to drying shrinkage of concrete in two different ways. First, certain aggregates need more water in the mix to produce the desired slump and workability, and the extra water increases shrinkage. Secondly, certain aggregates yield to the pressure from the shrinking paste and do not provide sufficient restraint against shrinkage. Moreover, the study recommended using lower water content in the concrete mix in order to reduce drying shrinkage. Another important factor is the cement type. The study indicated that Type II cement has lower heat of hydration and less drying shrinkage than Type I

cement. It was indicated that the less cement used, the less heat generated, leading to less water being required for hydration.

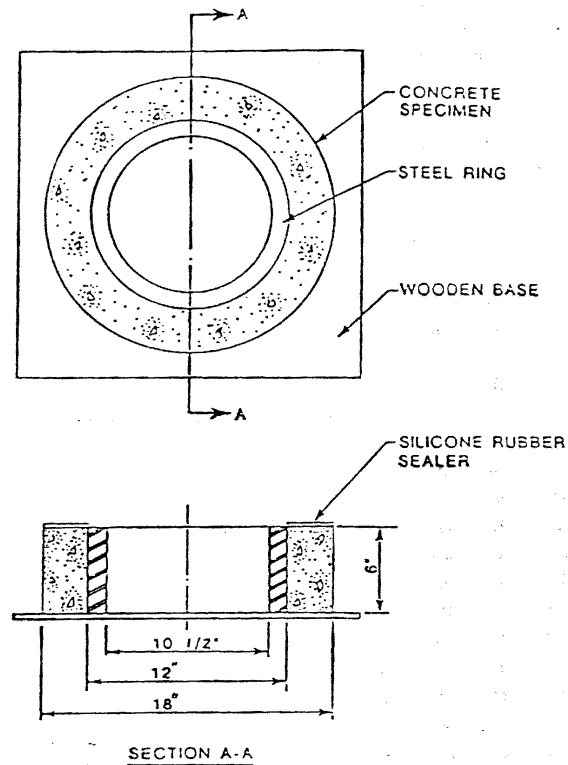
NCHRP report 380 is the most comprehensive study performed to date on transverse bridge deck cracking. It presents the results of a study conducted by Krauss and Rogalla in 1996. The study surveyed all U.S. Departments of Transportation and several overseas transportation agencies. They performed analytical studies and laboratory research, and conducted field measurements of bridge structures during and shortly after deck construction.

Krauss and Rogalla (1996) ranked the concrete material properties and material-related mechanisms that lead to early-age bridge deck cracking as shown in Table 2-1. Also shown are the factors affecting cracking related to design and construction issues. The study indicated that concrete material factors that are important in reducing early-age cracking include low shrinkage, low modulus of elasticity, high creep, low heat of hydration, and selection of aggregates and concrete that provide a low cracking tendency. Other material factors that are helpful in reducing the risk of cracking include reduction of cement content, use of shrinkage compensating cement and avoidance of silica fume admixtures and other materials that produce very high values of early compressive strength and modulus of elasticity. Concrete with very high early strength and modulus of elasticity is prone to cracking because it creeps very little. It was also recommended that use of other cementitious materials having less drying shrinkage should be pursued. Air entrainment, water reducers, retarders, and accelerators have minimal effects on cracking.

Krauss and Rogalla (1996) utilized the restrained ring test with some modification to measure the tendency of concrete to undergo drying shrinkage cracking, as well as to compare various concrete mixtures, curing, and environmental factors. The major advantage of the restrained ring test is that it takes into consideration all material factors that influence shrinkage cracking from the time of casting. Furthermore, it does not require complex calculations and is simple to execute. The test procedure is as follows: A 3-inch thick concrete ring is cast around a steel ring instrumented with strain gages. The strain accumulation and the length of time before cracking occurs indicate the cracking tendency of concrete. Concrete that creates less strain on the steel ring and takes longer to crack has a lower cracking tendency. The test apparatus consists of a

steel ring with an outside diameter of 12 inches, a radial thickness of 3/4-inches, and a height of 6-inches, as shown in Figure 2-1. The outside form is made from thin 1/8-inch polyethylene sheeting. Polyethylene-coated plywood is used for the base to minimize the friction restraint of the concrete.

Krauss and Rogalla (1996) used the ring test to investigate the effects of many factors such as water to cement ratio, cement content, aggregate size and type, silica fume, set accelerators and retarders, air entrainment, cyclic temperature, evaporation rate, curing, and shrinkage compensating cement. Rings cast with Type K expansive cement cracked much later than the control mix. Moreover, the mixes containing silica fume cracked 5 to 6 days earlier than the companion mixes without silica fume content. The test also showed that a mix with 28 percent of the Portland cement replaced with a Type F fly ash cracked only slightly later (4.3 days) than the control specimens.



**Figure 2-1. Cracking-tendency test apparatus reported by Krauss and Rogalla (1996)**

Table 2-1. Factors Affecting Cracking (Krauss and Rogalla, 1996)

Factors	Effect			
	Major	Moderate	Minor	None
<b>Design</b>				
Restraint	✓			
Continuous/simple span		✓		
Deck thickness		✓		
Girder type		✓		
Girder size		✓		
Alignment of top and bottom reinforcement bars		✓		
Form type			✓	
Concrete cover			✓	
Girder spacing			✓	
Quantity of reinforcement			✓	
Reinforcement bar sizes			✓	
Dead-load deflections during casting			✓	
Stud spacing			✓	
Span length			✓	
Bar type—epoxy coated			✓	
Skew			✓	
Traffic volume				✓
Frequency of traffic-induced vibrations				✓
<b>Materials</b>				
Modulus of elasticity	✓			
Creep	✓			
Heat of hydration	✓			
Aggregate type	✓			
Cement content and type	✓			
Coefficient of thermal expansion		✓		
Paste volume—free shrinkage		✓		
Water-cement ratio		✓		
Shrinkage-compensating cement		✓		
Silica fume admixture		✓		
Early compressive strength			✓	
HRWRAs			✓	
Accelerating admixtures			✓	
Retarding admixtures			✓	
Aggregate size			✓	
Diffusivity			✓	
Poisson's ratio			✓	
Fly ash				✓
Air content				✓
Slump <sup>†</sup>				✓
Water content				✓
<b>Construction</b>				
Weather	✓			
Time of casting	✓			
Curing period and method		✓		
Finishing procedures		✓		
Vibration of fresh concrete			✓	
Pour length and sequence			✓	
Reinforcement ties				✓
Construction loads				✓
Traffic-induced vibrations				✓
Revolutions in concrete truck				✓

<sup>†</sup> within typical ranges



Babaei and Fouladgar (1997) recommended the use of a mix design with cement content as low as possible in order to control thermal shrinkage. When less cement content is used, less heat of hydration is generated. Pozzolans and slag can be used as partial substitutes for Portland cement. It was also recommended that Type II cement be used rather than Type I because Type II has a lower heat of hydration. Furthermore, as a means of controlling thermal shrinkage, use of retarders in the mix is recommended to delay the hydration process and reduce the rate of heat generated. The effect of aggregate type on drying shrinkage was also studied. Using a soft aggregate such as sandstone tends to result in increased drying shrinkage, while use of hard aggregates such as quartz, dolomite, and high limestone tends to result in decreased drying shrinkage. Also, use of less water in the mix in an effort to reduce the evaporation rate after curing could reduce the amount of drying shrinkage.

Michael et al. (1997) studied the use of shrinkage compensating concrete (SCC) or Type K cement to reduce early-age bridge cracking. The Ohio Turnpike Commission (OTC) has used SCC exclusively for its new and replaced bridge decks for past 12 years, and has been quite satisfied with its performance to date. The study indicated that use of SCC has greatly mitigated shrinkage cracking. From the construction point of view, using SCC requires stricter attention to construction procedures than does ordinary Portland cement concrete. For instance, SCC has a shorter workable period and therefore should be placed by pumping. In addition, curing requirements for SCC are more demanding.

Shah et al. (1998) observed that cracking has been shown to increase with the use of higher strength concrete, especially with the addition of silica fume. Randomly distributed fiber reinforcement can be used to reduce the time to the first visible cracking and can significantly reduce crack width. Different fiber compositions can alter the degree to which this occurs. It was also found that with a two percent addition of shrinkage reducing admixture (SRA) by weight of cement, drying shrinkage could be reduced by nearly 50 percent.

Similarly, French et al. (1999) studied 72 bridges in the Minneapolis/St. Paul metropolitan area. In this study, the dominant material parameters associated with transverse cracking in bridge decks were identified as cement content, aggregate type and quantity, and air content. Data obtained from material reports for 21 of the bridge deck mixes (12 prestressed and 9 steel girder

bridges) were used in this study. It was observed that the concrete mix with the highest cement content [846 lb/yd<sup>3</sup>] cracked first, while the mix with the lowest cement content [470 lb/yd<sup>3</sup>] cracked last. Comparison of 21 bridges on the basis of aggregate type and quantity showed that increased aggregate quantity could result in reduced cracking. The study also indicated that increased air content (>5.5 percent) could result in reduced cracking.

Burrows (1998) studied the effect of aggregate type and content used in concrete mixtures on the drying shrinkage of concrete. In this study, limestone was found to be one of the aggregates that exhibited the least drying shrinkage, while sandstone exhibited the most drying shrinkage. Table 2-2 shows the effect of the type of aggregate on drying shrinkage as recorded by Burrows (1998).

**Table 2-2. Effect of Type of Aggregate on the Drying Shrinkage of Concrete**

Aggregate type	One-year shrinkage (percent)
Sandstone	0.097
Basalt	0.068
Granite	0.063
Limestone	0.050
Quartz	0.040

### **2.2.1 Concrete Constituent Materials and Selection Criteria**

Concrete properties and design should satisfy the requirements of specifications, expectations of construction engineers, and should be environmentally durable. Based on structural requirements, concrete strength can be designed, but strength is not the only parameter for achievement of a durable and sustainable structure. Severe environment conditions such as those in Michigan require more attention than regular environmental exposures. Since durability is the main concern for a concrete deck, selection of concrete constituent materials, construction practices, and construction intensity are essential factors to be considered. Selection of concrete constituent material is the most critical parameter to be examined. However, available durable materials may not result in a durable concrete design, regardless of practice (Shah et al. 1994).

In order to get maximum performance from all constituent materials, the performance of each individual ingredient of concrete should be known in terms of durability, mechanical and chemical properties, and interactions with other ingredients. However, it should be noted that complete certainty as to how ingredients will interact when combined in concrete mixture is not feasible. Particularly in production of durable concrete, any material incompatibilities will be highly detrimental to the concrete in service. Because of this, mix design optimization requires extensive testing of trial mixes (Shah et al. 1994).

In the European Concrete Standard for conclusive concrete performance, resistance to environmental exposure is given in terms of established concrete properties and composition limits. The local changes in environmental exposure may act differently on concrete. The requirements for each exposure class are specified in terms of permitted types and classes of constituent materials, maximum water/cement ratio, minimum cement content, minimum concrete compressive strength class (optional), and minimum air-content of the concrete. For instance, in a severe freeze-thaw environment where concrete is exposed to chemical salts, EN 206 requires at least 575 lb/yd<sup>3</sup> cement, 5000-6500 psi concrete strength range, 0.4 water/cement ratio, and minimum 4% air entrainment. In addition, the maximum water/cement ratio is given in increments of 0.05, and the minimum cement content is given in increments of 33.7 lb/yd<sup>3</sup>. Recommendations for the choice of limiting values for concrete composition and properties are given separately, based on type of cement. If the service life of a structure is estimated to be more than 50 years under normal maintenance conditions, and severity of the exposure conditions is worse than predicted, specific concrete compositions or specific protection and maintenance procedures are specified (EN 206 2000).

Shah et al. (1994) state that a compressive strength of least 6000 psi should be considered to be high strength concrete. The use of such a high strength concrete requires extensive care and better understanding of material and design. For convenience, the materials used in concrete design are discussed separately in the following sections.

#### *2.2.1.1 Portland Cement*

Cementitious materials have different chemical compositions and properties, and most concrete properties depend on cementitious materials. Cementitious materials are the most active

ingredients of concrete constituent material. Generally, the cost of cementitious material is higher than that of other constituent materials. The selection of cementitious material is important to achieve the most economic and durable concrete design. Most cementitious materials provide sufficient strength and durability under normal environmental conditions. Under severe environmental conditions such as those found in Michigan, freeze-thaw, deicing salt, and alkali silicate reaction are factors that require special attention. Any selection failure may have serious consequences. It is usually satisfactory to select general-purpose cements that are available in the local market. General purpose cements are described in ASTM C 150 as Type I and Type II, in ASTM C 595 as Type IP and Type IS, and in ASTM C 1157 as Type GU. Since these cements are largely available and used in the market, their quality and performance under some effects are known. General characteristics of cements given in ASTM C 150 (standard specification for Portland cement) and ASTM C 595 (Standard specification for blended hydraulic cement) are given in Table 2-3 and Table 2-4 respectively (ACI 225R-99 2001).

**Table 2-3. The Cement Types and Properties in ASTM C 150**

Type	Description	Optional Characteristics	% of US Shipments
<b>I</b>	General use	Air entraining, low alkali	86.6
<b>II</b>	General use; moderate heat of hydration and moderate sulfate resistance	Air entraining, moderate heat of hydration, low alkali	-
<b>III</b>	High early strength	Air entraining, moderate or high sulfate resistance based on C <sub>3</sub> A content, low alkali	3.3
<b>IV</b>	Low heat of hydration	Low alkali	Not available in USA
<b>V</b>	High sulfate resistance	Low alkali, sulfate resistant	

Cement chemistry has a great influence on the cement hydration process and therefore its mechanical properties. Portland cements are classified based on their chemical components. They are C<sub>3</sub>S (alite), C<sub>2</sub>S (belite), C<sub>3</sub>A (aluminate), and C<sub>4</sub>AF (ferrite). C<sub>3</sub>S exists in the clinker, it as a complex structure and may form six or seven different crystal structures. C<sub>2</sub>S also exists in clinker and has at least five crystal forms, unlike C<sub>3</sub>S, the formation of crystals differs with

performance.  $C_3A$  can be found in different crystal forms in concrete and it hydrates faster than other clinker phases.  $C_4AF$  also has many different crystal forms but has a slow hydration rate. Because of this, it is often considered less important than  $C_3A$  (ACI 225R-99 2001).

**Table 2-4. The Cement Types and Properties in ASTM C 595**

Type	Name	Blended Ingredients Range		Optional Characteristics
		Pozzolan	Slag	
<b>I (PM)</b>	Pozzolan-modified Portland Cement	0 - 15	-	Air entraining, moderate sulfate resistance, moderate heat of hydration
<b>IP</b>	Portland Pozzolan Cement	15 - 40	-	Air entraining, moderate sulfate resistance, moderate heat of hydration, alkali reactivity resistance
<b>P</b>	Portland Pozzolan Cement	15-40	-	Air entraining, moderate sulfate resistance, low heat of hydration, alkali reactivity resistance
<b>I (SM)</b>	Slag modified Portland Cement	-	0-25	Air entraining, moderate sulfate resistance, moderate heat of hydration
<b>IS</b>	Portland Blast-furnace slag	-	25-70	Air entraining, moderate sulfate resistance, moderate heat of hydration, alkali reactivity resistance
<b>S</b>	Slag cement	-	70-100	Air entraining, moderate sulfate resistance, alkali reactivity resistance

The strength of cement basically depends on  $C_3S$  and  $C_2S$  content. Their percentages in clinker affect the heat of hydration and the appropriateness of additional cementitious admixtures to cement (ACI 225R-99 2001).

### 2.2.1.2 Shrinkage Compensating Cements

Shrinkage compensating cements are hydraulic cements that expand slightly during the early hardening period after setting. This expansion is used to compensate for the shrinkage of concrete. There are three different types of expansive cements based on their active ingredient types. They are referred to as K, M, and S. All types of expansive cements are manufactured to produce the proper amount of expansion without adverse effects.

**Table 2-5. Expansive Type of Cements and their Constituents**

Expansive Cement	Principal Constituents	Reactive Aluminates Available for Ettringite Formation
<b>K</b>	<ul style="list-style-type: none"> <li>• Portland cement</li> <li>• Calcium sulfate</li> <li>• Portland like cement containing <math>C_4A_3S</math></li> </ul>	$C_4A_3S$
<b>M</b>	<ul style="list-style-type: none"> <li>• Portland cement</li> <li>• Calcium sulfate</li> <li>• Calcium-aluminate cement CA and <math>C_{12}A_7</math></li> </ul>	CA and $C_{12}A_7$
<b>S</b>	<ul style="list-style-type: none"> <li>• Portland cement high in <math>C_3A</math></li> <li>• Calcium sulfate</li> </ul>	$C_3A$

The effect of use of chemical admixtures with expansive cements is not clearly presented to date. The cement chemistry directly affects the performance of admixtures. Trial batches are required to be issued with job materials and kept under ambient environmental conditions. Mixing time, transportation period, and reaction of admixtures should be controlled during the trial tests. Results may vary even if the laboratory tests are satisfactory. Air entrainment agents are effective, but some water reducers and retarding agents may be incompatible. Existence of  $CaCl_2$  in concrete may affect the expansion rate and increase shrinkage. Supplementary cementitious materials (fly ash and other pozzolans) may reduce expansion and other physical properties of concrete made with expansive cements.

Although expansive cements require more water than Portland cements, compressive strength is comparable. Other physical properties of concrete made with expansive cements, such as modulus of elasticity and creep, are identical to ordinary Portland cement (ACI 223-98 2001).

Restraint of expansive cement is important in construction of concrete decks. Restraint due to girders and adjacent structural elements is indeterminate and may cause either too much or too little restraint. High restraint will induce high compressive strength in concrete at an early age but provide less shrinkage compensation (ACI 223-98 2001).

### 2.2.1.3 *Supplementary Cementitious Materials*

Supplementary cementitious materials, also called mineral admixtures, contribute to the properties of hardened concrete through hydraulic or pozzolanic activity. Typical examples are natural pozzolans, fly ash, ground granulated blast-furnace slag, and silica fume. Supplementary materials can be used individually with Portland cement or blended cement, or in different combinations. These materials are often added to make concrete mixtures more economical, reduce permeability, increase strength, or influence other concrete properties (PCA@ 2003). Each of these supplementary materials has specific properties to be considered before mixture properties are ascertained. These supplementary materials are discussed separately in subsequent sections (ACI 211.1-97 2001).

#### 2.2.1.3.1 *Fly Ash*

Fly ash is mainly a by-product of burning coal in power plants. The coarse burned coals are crushed and ground to a fineness of 75  $\mu\text{m}$ . ASTM C 618 classifies fly ash into two main groups based on its chemical composition in terms of iron oxide ( $\text{Fe}_2\text{O}_3$ ), aluminum oxide ( $\text{Al}_2\text{O}_3$ ), and silicon dioxide ( $\text{SiO}_2$ ). If the summation of  $\text{SiO}_2$  (35% – 60 %),  $\text{Al}_2\text{O}_3$  (10 % - 30 %), and  $\text{Fe}_2\text{O}_3$  (4% - 20%) is greater than 70%, fly ash is categorized as Class F. If the summation is above 50%, it is classified as Class C. Generally Class C fly ash has more than 20% CaO (1-35%) (ACI 232.2R-96 2001).

The performance of Class C and Class F fly ash shows different characteristics; however the performance of fly ash is not directly based on its classification. The general approach for evaluation of fly ash is to evaluate its performance with regard to increasing the resistance of concrete to alkali silicate reaction and sulfate attack (ACI 232.2R-96 2001).

The shape, glass formation, particle size distribution, and density of fly ash are very important factors when hydration of cementitious material and hardened concrete properties are considered. Fly ash contains small glassy spheres because the burned coal cools rapidly. The composition of the glassy spheres depends on the composition of coal and the temperature at which coal is burned. Since the coal sources and technologies at each power plant are different, properties of fly ash (specific density, particle size and shape) also differ. The use of fly ash is based on a

given cement and its chemical composition. The chemical composition of fly ash varies more than other supplementary materials even if the source of fly ash is the same.

Fly ash addition generally increases the paste volume as well as the drying shrinkage. If the water added to the mixture is kept constant, fly ash has no effect on drying shrinkage. The amount of fly ash added to the mixture is important. When the amount of fly ash added to mixture is in a range of 0-20 % of cement mass, the mixture has the same or slightly less shrinkage than ordinary Portland cement concrete. According to ACI 232 (2001), Malhotra states that if the amount of fly ash added to concrete design is more than 40% of the mass of cement, the deicing scaling performance of such concrete is suspicious (ACI 232.2R-96 2001).

The effects of fly ash addition on hardened concrete are a reduction in heat of hydration, lowered permeability, and improved resistance to sulfate and chemicals. Curing practice is important when attempting to gain permeability and chemical resistance properties. Poor curing can result in unsatisfactory performance (Day 1999).

#### *2.2.1.3.2 Ground Granulated Blast-Furnace Slag (GGBS)*

A by-product of the iron working industry, GGBS is a blast-furnace slag that has been dried and ground to fine powder. The slag used in concrete production is specific for its hydraulic reaction. This reaction is related to rapid cooling of slag in steel production plants. This rapid cooling process creates glassy forms. Slow cooled slags are predominantly crystalline and do not possess significant cementitious properties. The principal hydration product of slag is essentially the same product formed when Portland cement hydrates. Although the hydration of slag is slower than that of ordinary Portland cement, the hydration of slag is more gel-like than the ordinary Portland cement. Hydration of slag adds denseness to the cement paste. The hydration of Portland cement, alkali salts, or lime increases the hydration rate of slag. The hydration of slag depends largely on the breakdown and dissolution of the glassy slag structure.

In general, hydration of slag in combination with Portland cement at normal temperatures is a two-stage process. When cement, slag, and water are mixed, slag reacts with the calcium hydroxide available in the mixture. This is referred to as initial hydration. After the cement begins hydration, the slag reacts with calcium hydroxide, which is a by-product of cement hydration. This is the second stage of slag reaction. The calorimetric studies of rate of heat



generation prove this two-stage process. If the early stage of slag hydration requires additional alkali salts, calcium hydroxide, or sulfates, the reaction of slag itself with water is negligible.

Elevated temperatures during the hydration increase the solubility of alkali hydroxides from cement, therefore increasing the reactions of slag. Slag is able to bind more alkalis than ordinary Portland cements due to its lower calcium silica ratio. Alkali hydroxide alone can hydrate slag to form a strong cement paste structure that may be used in special applications.

The usage of slag is predominantly based on the chemical composition of slag, alkali concentration of the reacting system, glass content of slag, fineness of slag and cement, and ambient temperature during early phases of hydration. Since the hydration of slag is influenced by so many complex factors, earlier attempts failed to provide adequate evaluation criteria for use in practice. The ASTM C 989 slag activity index is often suggested as a basic criterion for usage and evaluation of slag.

The proportion of slag is generally 25 –70 % of total cementitious materials. Recent research has shown that optimum slag usage is 50 % of cementitious material. Use of a large amount of slag makes proper curing practice more critical. Since the density of slag is lower than that of ordinary Portland cement, there is a need to change the solid content of concrete design. This change is often made to coarse aggregate content in order to reduce water demand and shrinkage (ACI 233R-03 2003).

Similar to fly ash, most of the good properties of slag concrete are related to curing practices. Poor curing of slag concrete can dramatically reduce most of its predicted properties (Day 1999).

With the exception of setting time, concrete properties of slag mixtures are almost identical to ordinary cement mixtures. The setting time of a slag mixture depends on environmental temperature. Paste volume and aggregate content of the mixture should be controlled. It should be noted that regardless of the concrete ingredients, the cement or supplementary materials must be kept moist during early hydration (ACI 233R-03 2003).

### 2.2.1.3.3 *Silica Fume*

Silica fume is a by-product of the production of silicon metal or ferrosilicon alloys. It contains a high content of amorphous silicon dioxide and some other very fine particles. Silica fume should not be used in concrete unless data with regard to the use of micro silica shows favorable performance (ACI 234R-96 2001).

Different types of silica fume can be found in the market. Examples are blended silica fume cements, as-produced silica fume, slurried silica fume, densified (condensed) silica fume, and pelletized silica fume. As-produced silica is difficult to handle as compared with cement, slag or fly ash. The flow of micro silica creates some problems with pneumatic systems in cement plants. Of primary concern, micro silica inhalation may create health hazards. Slurried silica is developed to overcome handling difficulties of as-produced silica fume. The slurried micro silica contains 40-60 % of micro silica by mass depending on the source. Some manufacturers include a superplasticizer that is capable of controlling silica fume concrete properties (ACI 234R-96 2001).

Micro silica has ultra fine smooth spherical glassy particles with a 97,634 ft<sup>2</sup>/lb specific surface compared to normal cement fineness of 1465-1953 ft<sup>2</sup>/lb. The fineness of silica fume is measured by using different methods, but results vary due to the extreme fineness and carbonic composition of silica fume (ACI 234R-96 2001).

Properties of micro silica differ from source to source, and the published data is very limited. The variation of silica fume quality can be compared to that of slag quality, but doesn't vary as much as fly ash quality. This is due to high quality control measures in the metallurgical industry (ACI 234R-96 2001).

The use of silica fume in concrete increases the mixing water demand. High range water reducers can control the increasing water demand and solve this problem. If appropriate precautions are taken, silica fume does not affect the workability and slump significantly. When water-reducing admixtures are used, setting time may be affected. Segregation and bleeding may be reduced. Use of silica fume significantly reduces early-age drying shrinkage (ACI 234R-96 2001).

The effects of silica fume on fresh and hardened concrete properties vary with the amount of micro silica used in the mixture. Discussion of the effects of silica fume addition is generally categorized with regard to percentage added, either more or less than 10%. As a general concept, addition of micro silica in higher percentages affects the water demand, drying shrinkage, and time of setting. Silica fume has finer particles than cement and other cementitious materials. Those finer particles fill the space between the relatively coarser cement particles and help the concrete flow. Excessive addition of silica fume, more than 20%, makes concrete sticky. However, the filling effect of silica fume is useful with regard to pumping and placement of concrete. If the addition is less than 10%, the effect of silica fume on setting time and workability is negligible. The effect of silica fume addition on drying shrinkage can be protected by common curing procedures (Swamy et al. 1986).

The effect of silica fume addition to hardened concrete is also important. Since the finer particles of silica fume fill the spaces between coarser cement particles, bleeding and segregation of concrete drastically reduces. This reduction affects the drying shrinkage based on silica fume percentage. The finer structure of silica fume concrete results in changes to the pore structure of concrete. This change increases the resistance of concrete to aggressive chemicals, freeze-thaw, and abrasion, and reduces the permeability of concrete (Swamy et al. 1986). The use of silica fume regulates the pore structure by decreasing the number of large pores and distributing them homogeneously. Total porosity, however, will not be affected significantly. The available micro cracks and holes in the transition zone between cement paste and aggregate will be healed. These positive effects reduce the permeability of concrete (ACI 234R-96 2001).

The use of silica fume increases the strength of concrete. Addition of silica fume in amounts less than 5% does not increase the early-age strength, but it may increase the 7 and 28-day strengths as much as 10% and 20% respectively (Swamy et al. 1986). For high strength concrete, silica fume may be added in amounts as much as 20%. However, other consequences should be taken into account (Shah 1999).

Shah et al. (1994) examined the fracture mechanics of high strength concrete and the effects of concrete composition on fracture. An increase in the addition of silica fume increases the crack resistance of concrete; correspondingly, an increase in silica content increases the brittleness of

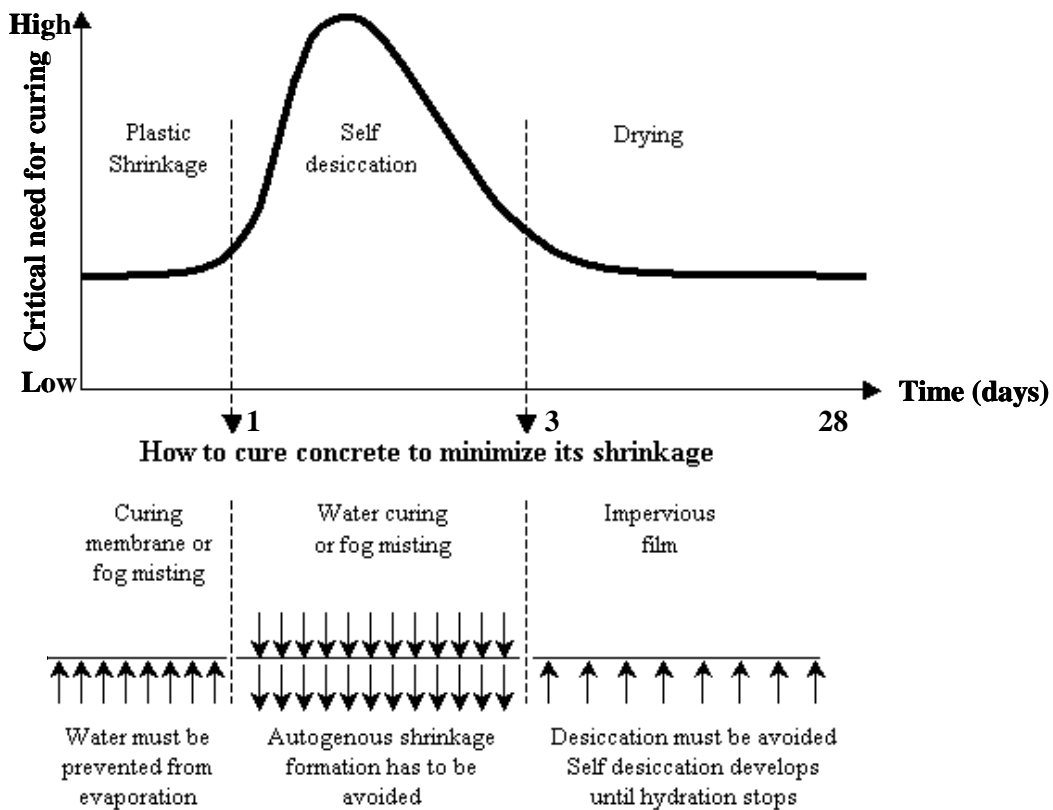
concrete. Concrete composition can be expressed as aggregate, cement paste and aggregate-mortar interface. Since high performance concrete has higher paste strength than that of normal strength concrete, its resistance to cracking is not related to aggregate size. Angularity of aggregate is found to be more critical than aggregate size when predicting crack resistance of high strength concrete. Also, an increase in water/cement ratio and air content adversely affect the crack resistance of concrete. Pores that are usually present in concrete have a large effect on cracking of concrete. Precautions that regulate the pore structure increase the tensile resistance, and therefore enhance the crack resistance of concrete. Use of silica fume reduces concrete cracking potential (ACI 234R-96 2001).

#### *2.2.1.4 Ternary Systems*

The use of supplementary materials in combination with Portland cement is not uncommon, especially in high performance concrete production. The use of Portland cement as the third cementitious material is referred to as a ternary blend or ternary system. Slag, micro silica, and fly ash are the most commonly used materials in ternary systems. Most of the durability problems that arise with the use of ordinary Portland cement can be treated by using ternary systems. In the meantime, Malhotra reported that these systems may provide similar properties to those of ordinary cements with the exception of resistance to a freeze-thaw environment. A freeze-thaw environment requires a minimum of 340 lb/yd<sup>3</sup> of Portland cement and a low water/cement ratio (ACI 223-98 2001).

Haque (1996) examined the curing regime of some common ternary blends that contained 70-75% Portland cement, 5-10% micro silica, and 20% fly ash or slag, for 3, 7 and 28 days of moist curing. After samples were moist cured, they were kept under  $40 \pm 5\%$  relative humidity. The mechanical properties (strength, modulus of elasticity, water penetration and drying shrinkage) and effects of curing on those specimens were tested. It was found that addition of 10% condensed micro silica improved the strength and other mechanical properties of concrete, but addition of fly ash was suspicious with regard to performance. Addition of condensed micro silica also reduced the consequences of short curing periods. The addition of condensed micro silica reduced the drying shrinkage; further addition of fly ash and slag, however, increased the shrinkage of concrete.

Recent research made on the durability characteristics of high performance concrete with a ternary mixture emphasizes that the curing of high strength concrete is unique and different from that of normal strength concrete. The autogenous shrinkage of ternary systems is found to be homogenous through the cross section. The autogenous shrinkage is more critical than drying shrinkage for ternary systems. Drying shrinkage is found to be effective at the surface of concrete members. Since permeability of high strength concrete is lower than that of normal strength concrete, the curing regime in Figure 2-2 is found to be critical. The curing of high strength concrete during the first 12-36 hour period following placement is very critical. After that, the pore structure of concrete will have developed and lower permeability will result in self-desiccation of the concrete member. Furthermore, the first 2-3 days of curing is also essential for high strength concrete (Aitcin 2003).



**Figure 2-2. The most appropriate curing regimes during the course of the hydration reaction**

### 2.2.1.5 Effects of Chemical Admixtures on Concrete

Chemical admixtures are defined as materials used in concrete other than water, aggregates, hydraulic cement, and fiber reinforcement. They are added to concrete or mortar immediately before or during mixing.

Since the strength and other properties of concrete are controlled by the cement content and water/cement ratio, chemical admixtures are often used to reduce the water/cement ratio, and improve concrete properties. Chemical admixtures should conform to ASTM C 494 requirements. The types of chemical admixtures in ASTM C 494 are listed in Table 2-6.

**Table 2-6. Types of Admixtures in ASTM C 494 and Definitions**

Type of Admixture	Definition
Type A	Water Reducing
Type B	Retarding
Type C	Accelerating
Type D	Water reducing and retarding
Type E	Water reducing and accelerating
Type F	Water reducing, high range
Type G	Water reducing, high range and retarding

When used in the recommended dosage rates Types A, D, and E admixtures ordinarily reduce the water demand of a mixture by 5% - 8 %, while Types F and G reduce water demand by 12% - 25 %. Types F and G are often called superplasticizers.

The manufacturers' recommendations and literature should be considered when determining the required chemical admixture dosage for each design. Chemical admixtures have some adverse effects when used in high dosages. Examples are excessive retardation (uncontrolled setting) and increased air entrainment. Also the total chloride in an admixture should be accounted for in order to ensure durability. Types A, B, and D are generally recommended to be used in small dosage (2 to 7 oz/100 lb. cementitious material) in concrete design. Types C, E, F and G are generally recommended to be used in large quantities (10 to 90 oz/100 lb. cementitious material),

and their water content should be included when calculating total water content of the concrete mixture. Sometimes there is a need to use a combination of admixtures in the same mix design. The total amount of combined chemical admixture should be taken into account when calculating the water content of the concrete mixture.

Before using the admixtures manufacturer's recommendations, ASTM C 494, ACI 318 and ACI 301 should be considered.

#### *2.2.1.5.1 Air Entraining Admixtures*

Air entraining admixtures create an air void system that can protect the concrete from freeze and thaw exposure. The amount of air and void spacing are essential for air entrainment applications. The nature and content of the air entrainment admixture, concrete constituent materials, other chemical admixtures, employed mixing time, slump, and degree of consolidation are key factors that must be taken into account to ensure achievement of the projected air content (ACI 212.3R-91 2001).

Interactions between air entrainment and other water reducing and/or shrinkage reducing admixtures should be controlled. The effect of decreasing water content may increase the spacing between voids, or employing shrinkage reducing admixture could reduce the efficiency of an air entrainment agent (ACI 212.3R-91 2001).

The effect of increased air on fresh concrete is beneficial for reduction of water/cementitious materials ratio at a constant workability, since increased air content increases the workability of concrete. The bleeding and segregation also decreases when increasing the amount of air entrainment. Contrarily, increasing cement content may create some problems with air entrainment (ACI 212.3R-91 2001).

The effect of increased air on hardened concrete is a general reduction in the strength in concrete with moderate to high cement contents, in spite of decreased water content. The loss of strength is proportional to amount of air entrainment, but the rate of reduction increases with higher amounts of air entrainment (ACI 212.3R-91 2001). On the other hand, flexural strength of concrete does not show any significant change when increasing air entrainment up to 6%.

Not every chemical that is capable of producing air bubbles in cementitious material can be considered to be an air-entraining admixture. Furthermore, an air-entraining admixture should be capable of developing a sufficient air void system. Wood resins, synthetic detergents, sulfonated lignin salts, petroleum acid salts, organic sulfonated hydrocarbons, fatty and resinous acids, and their salts can be classified as agents that are able to develop a sufficient air void system in cementitious materials (ACI 212.3R-91 2001). A sufficient air void system makes the concrete more curing tolerable (Rixom et al. 1999).

An air content of 6% may not be sufficient when durability is considered. The amount of air entrainment should be controlled by the size of air voids and spacing. Research performed by the Virginia DOT showed that an increase in the amount of cementitious material may require control of the amount and distribution of air entrainment (Ozyildirim et al. 2003).

#### *2.2.1.5.2 Water Reducing and Set Controlling Admixtures*

Water reducing admixtures are a group of products that are added to concrete to achieve certain workability at a lower water/cement ratio than that of the control concrete. The water reducing admixtures are produced using one of the following materials: lignosulfonic acids, hydroxylated acids and salts, derivations of lignosulfonic acids and hydroxylated acids, sulfonated melamine product salts, high molecular weight condensation of naphthalene sulfonic acids, blends of naphthalene or melamine condensates with other water reducing or set controlling agents, and other inorganic materials such as amines, sugar acids, polymeric compounds, melamine and naphthalene derivations, silicones, and sulfonated hydrocarbons.

The use of set controlling or other chemical admixtures has no effect on the heat of hydration under the same adiabatic temperature. The occurrence of peak heat of hydration may be regulated (accelerated or delayed) but cannot be reduced with the use of the same type and amount of cement.

Water reducers have an impact on fresh as well as hardened concrete. Fresh concrete requires a lesser water/cement ratio than concrete without water reducers at the same workability. Because of this, the final strength of concrete using water reducers in their mix designs is higher. With improved concrete strength, other mechanical properties of concrete are similarly improved. Water-reducing admixtures can provide a certain level of air entrainment. The interaction



between air-entrainment agents and water-reducing admixtures should be controlled. The effect of water reducers on shrinkage shows conflicting data. As a general concept, use of water reducing admixtures increases the early-age shrinkage but decreases the long-term shrinkage.

#### *2.2.1.5.3 Shrinkage Reducing Admixtures*

Hydrated cement paste shrinks as it loses moisture from its extremely small pores. As the moisture is lost in these pores, the surface tension of the remaining water tends to pull the pore walls together and results in loss of volume over time (ConcreteNetwork@ 2003). Shrinkage reducing admixtures are designed to decrease the effects of drying shrinkage by reducing the surface tension in the pores. The amount of shrinkage depends mainly on water/cementitious material ratio. It is also affected by parameters that affect pore size distribution such as cementitious material type and fineness, and chemical admixtures. Some glycol ether blends have a tendency to reduce surface tension. This type of chemical admixture is called a shrinkage reducing admixture, which is available in the market.

Shrinkage reducing admixtures are added to mixing water in amounts of 1-2.5% of the mass of cementitious materials. The optimum range is found to be around 1.5%. The effect of shrinkage reducing admixtures on fresh concrete is negligible.

As a general concept, use of shrinkage reducing admixtures with lower water/cementitious material ratios result in a greater percentage of shrinkage reduction. Concrete with water/cementitious material ratio of 0.6 or less resulted in 80% or more shrinkage reduction at 28 days and 70% or more shrinkage reduction at 56 days. Concrete with a higher water/cementitious material ratio had a level of shrinkage reduction at 28 and 56 days of 37% and 36% respectively. In addition to the shrinkage reduction effect, shrinkage-reducing admixtures help to reduce thermal cracking by retarding the hydration process of concrete.

The main effect of a shrinkage-reducing admixture is on compressive strength of concrete. Addition of approximately 2% of shrinkage reducing admixture can reduce the 28-day strength as much as 15%. This strength reduction is observed with increasing water/cementitious material ratio. Therefore, it is recommended that shrinkage-reducing admixtures be used with superplasticizers (Rixom et al. 1999).

### *2.2.1.6 Aggregates*

Aggregates are a major constituent of concrete volume, and they influence the properties and performance of concrete. When an aggregate performs below the expected level, the resultant concrete will be unsatisfactory and therefore, the service life of the structure is shortened (ACI 221R-96 2001).

The aggregate should be durable enough to sustain the properties of concrete under all exposure conditions. For this reason, durability and strength of aggregates are quite important. Freeze-thaw resistance, strength, shrinkage, thermal properties, and surface properties should be considered when selecting aggregates. The effect of aggregates on fresh concrete properties such as slump and workability, pumpability, and bleeding also contribute to concrete durability and should be taken into consideration during selection (ACI 221R-96 2001).

Important parameters of coarse aggregates in high strength concrete are their shape, texture, and maximum aggregate size. In the case of normal strength concrete, aggregate is generally stronger than paste. The strength of the aggregate is not a major factor in early ages of concrete. However, as the concrete strength rises, the aggregate contributes a great deal to strength and other properties of concrete (Shah et al. 1994).

### *2.2.1.7 Other State DOTs' Practice*

By use of their websites, an evaluation of other state highway agencies with similar climatic exposure to that of Michigan was performed. Deck concrete strength, maximum aggregate size, water/cement ratio, cementitious material content, air content and types of chemical admixtures were extracted from specifications posted on the sites (Table 2-7).

Most of the states prefer the use of coarse to total aggregate ratio or coarse to total weight ratio rather than volumetric ratios. Water/cement ratio is nearly constant at 0.4. Total cementitious material content varies from state to state. This is due to regional practices and durability considerations. Wisconsin is the only state that uses Type I cement mix in deck concrete. The other State DOTs prefer blended mixtures. Generally, a blending operation is performed using Type I cement. The variations in slag and fly ash usage can be expressed with regard to regional source characteristics and construction practices. Air entrainment is about 6 % but some lower

(4.5%, Wisconsin) and higher (9%, Ohio) percentages are also observed. The type of admixture is important in order to satisfy water/cement ratio and workability requirements. Ohio and Illinois DOTs require a high range water reducer because their workability need is very high, around 8 inches at the construction site. The retarding effect is required for hot weather conditions.

**Table 2-7. The Deck Concrete Design in other States with Similar Exposure to Michigan**

DOT	Strength (psi)	D <sub>max</sub> (in)	W/C	Cementitious material content (lb)	Type of cementitious material				Air %	Admixture
					Cement %	Fly ash %	GGBS %	Silica fume %		
Wisconsin Class D	4000	1	0.4 – 0.47	610	Type I	-	-	-	6±1.5	Water reducer
Minnesota			0.4	611	Type I	20	-	5	6.5	Water reducer
Illinois Class BD	4000*	1.5-1	0.44	607	Type I	Type F 15 or Type C 20	-	-	5-8	High Range water reducer
					Blended					
Ohio Class HP 3 or 4	4000 >	1-3/4	0.4	660	Type I	Type C 23		5	7±2	High range water reducer
				660	Type I		29	5		
New York Class HP	4000	1.5	0.4 – 0.44	682	Type SF, Type IP, Type SG				Av. 6.5 (5-8)	Water reducer
					Type I	20	6			

\* 14-day strength

### 2.2.1.8 Concrete Design

Concrete is made up of aggregates, a hydraulic binder, and water and may contain other cementitious materials and/or chemical admixtures. Chemical admixtures are used to accelerate, retard, or improve consistency, reduce water demand, and increase compressive strength or alter other properties of concrete as explained in ACI 212.3R-96 (2001). Depending on the type and the amount of supplementary cementitious materials, it may be possible to enhance the specific

properties of fresh and hardened concrete. Examples of properties that can be changed are reduced heat of hydration, improved late age strength, reduced permeability, and increased resistance to alkali aggregate reaction, sulfate attack or abrasion. Reduced heat of hydration and reduced early-age strength reduces deck cracking.

The selection of concrete mix proportions requires an optimization of economy and other characteristics such as placeability, strength, durability, density and appearance. The selected materials as well as the technique used for placement govern the required characteristics. These concrete characteristics should be stated and explained in the specifications.

Concrete designs should be subjected to trial batches for purposes of revision. The trial batches should include a field trial if possible. Observations should be made for characteristics that may suggest potential changes in the mix design. Any change in the mixture proportions, chemical admixtures and/or materials should be verified by additional trial batches.

Concrete proportions are determined based on placeability, density, strength and durability requirements for a particular application. Placeability of concrete is of major concern. This term can roughly be compared to consistency and workability of concrete. Workability of concrete can be expressed as a property of concrete that determines its capacity to be placed and consolidated properly, as well as to be finished without segregation. Workability embodies such concepts as moldability, cohesiveness, and compactability. The grading of aggregate, maximum size and shape of aggregate, amount of cementitious materials, chemical admixtures, and entrained air affect workability. Each of these factors is important and should be considered in order to achieve satisfactory placeability of concrete.

Consistency can be explained as the mobility of concrete. It is measured in terms of the slump of fresh concrete. The ease of concrete flow during placement is affected by the consistency. The aggregate size, angularity and texture, available air entrainment, and chemical admixtures affect the amount of water demand in properly portioned concrete (ACI 211.1-97 2001).

Strength is a main characteristic of concrete, but other characteristics such as durability and permeability should be considered. Generally, the 28-day strength of concrete is used for structural design, proportioning, and evaluation.

For given materials and conditions, concrete strength is determined by the cementitious material and water content. The actual water content that should be considered in concrete design is the water content after deducting any water absorbed by aggregates. In addition, water demand may vary due to size, grading, shape and stiffness of the aggregate. Some cement types, air content of mix design, and chemical admixtures also affect the water demand. These effects are predictable and should be considered during the concrete mix design process (ACI 211.1-97 2001).

Concrete should be capable of enduring various exposures and service loads during its service life. Freeze-thaw, wetting-drying cycles, chemical materials, and deicing salts are included among the potential exposures. Some of these exposures require specific cementitious material properties that ordinary Portland cement cannot provide. Using low water/cementitious material ratio prolongs the life of concrete by reducing the penetration of water and aggressive chemicals into concrete. Severity of exposure should be considered during concrete design, such as the case of Michigan's environment (ACI 211.1-97 2001).

The hydration of cement is an exothermic chemical process that generates about 150 to 350 joule/gram, depending on cement type. This generated heat has an important impact on concrete when it is fresh. Heat of hydration is roughly proportional to amount, fineness, and C<sub>3</sub>A content of cement. A lower water/cement ratio generates decreased heat and increased tensile strength. Addition of silica fume increases the generation of heat and the heat of hydration impact. For members that have a thickness less than 1.6 ft, the effect of this temperature rise may be ignored. For a bridge deck, which is highly sensitive to cracking, a mix design may be utilized to provide a relatively low heat of hydration (Mehta et al. 1994)

#### *2.2.1.8.1 Concrete Design (ACI 211.1-97 2001)*

Estimating the required mix design values for concrete involves a sequence of logical and straightforward steps that fit the characteristics of regionally available materials. Some exposure conditions and specifications may require some of the following items: maximum water/cementitious material ratio, minimum cement content, a certain air content, workability (slump), maximum size of aggregate, strength (at 28-day or other specific early ages), etc. The ACI 211.1 (2001) procedure is very straightforward and follows some simple steps as discussed below.

Step 1 consists of the determination of workability. The workability should be selected based on placement system, use of admixtures, and type of structure. For deck and pavement construction, slump is specified as 1-3 inches.

Step 2 involves choosing the maximum aggregate size. The larger the aggregate size, the lower the water demand, therefore, choice of a larger aggregate is more economical. However, selection of aggregate size is also related to reinforcing steel, workability, and consolidation technique.

Step 3 estimates the mixing water and air contents. For normal strength concrete, workability is related to nominal aggregate size, particle shape, grading, concrete temperature, air content and use of chemical admixture. ACI provides a summary table depending on the air entrainment and maximum aggregate size. The values given in the table is for concrete without admixtures. They give a good estimation for first trial batches.

Step 4 involves the selection of water/cementitious material ratio. Water/cementitious material ratio is not only related to strength but also to durability. Lower water/cementitious material ratio is desirable for better results with regard to strength and permeability.

The proportion of materials is based on an absolute volume equivalency technique. When water and water/cement ratio are defined, cement content is calculated. The volume of water, cementitious material and entrained air are deducted from a unit volume. The proportion of coarse and fine aggregates is determined by their gradation (ACI 211.1-97 2001).

### **2.3 DESIGN RELATED ISSUES**

Dakhil et al. (1975) studied the influence of concrete cover, diameter of rebars, and slump on crack formation in plastic concrete. They reported that crack occurrence tends to decrease with increasing concrete cover over the reinforcement. Concrete slump and reinforcement bar size also influence cracking, but to a considerably lesser degree than concrete cover. Higher slump concrete and larger reinforcing bars tend to be found in structures more susceptible to cracking.

Krauss and Rogalla (1996) listed various design factors and ranked them according to their influence on cracking, as shown in Table 2-1. These design factors are restraint, bridge type

(continuous/ simple span), girder type (e.g., steel, concrete, composite, etc.), girder size and spacing, form type, skew, concrete cover, and other factors. It was found that cracking is more common among steel girder structures. Multi span continuous composite large steel girder bridges are most susceptible to cracking because of additional restraint. Stay-in-place deck forms were also found to have influences on deck cracking. Concrete cover over reinforcement is an important factor affecting cracking. Cover thickness between 1.5 inches and 3 inches was recommended.

Ramey et al. (1997) recommended 14 specific actions to be considered by structural designers to mitigate concrete cracking and in turn enhance bridge durability. These actions cover the size of deck reinforcement, rebar arrangements, concrete cover, deck thickness, w/c ratio, cement type, and deck construction sequence.

Similarly, French et al. (1999) reported that bridges with simply supported prestressed girders were observed to be in better condition than continuous steel girder bridges. For steel girder bridges, end restraint and shrinkage were the most important factors contributing to extensive deck cracking. The cracking in steel girder bridges increases with curved bridges, and on interior spans as compared to end spans.

Schmitt and Dawin (1999) indicated that cracking in bridge decks is generally believed to be caused by settlement adjacent to reinforcing bars and volume change.

Insufficient top reinforcement cover, improper placement of reinforcement, and insufficient deck thickness cause concrete cracking (Issa 1999).

## **2.4 ENVIRONMENTAL OR SITE CONDITIONS**

Many researchers studied the effects of environmental conditions at the time of casting on the properties of fresh and hardened concrete. These environmental conditions are air temperature, relative humidity, and wind velocity. Elevated temperature and low relative humidity, or a combination of the two accelerates plastic shrinkage of concrete. If plastic shrinkage is restrained, cracks are formed. Plastic shrinkage cracks appear when the surface evaporation rates exceed the rate at which bleeding water rises to the concrete surface. Several investigators

and transportation departments believe that the effects of environmental conditions during concrete placement are the most significant factors affecting deck cracking.

Babaei and Hawkins (1987) observed more cracking in concrete cast during low humidity and with high evaporation rates. Transportation agencies reported that casting at night can significantly reduce deck cracking.

Purvis et al. (1995) recommended the use of retarders to reduce a rise in the temperature of concrete when ambient temperature is expected to reach 75°F or more. In hot weather, attempts should be made to cover concrete with wet burlap no more than 30 minutes after the surface is finished and textured; the burlap should be kept wet continuously. The study also recommended placement of concrete at night in hot weather to minimize heat that builds up from cement hydration, as well as ambient heat.

Krauss and Rogalla (1996) indicated that the evaporation rate should be measured at the job site, and wind breaks, fogging and evaporation retarder films should be used during periods of high evaporation, and during cold or hot weather. Moreover, concrete bridge decks should be placed during early or mid-evening whenever possible. Doing so reduces hydration temperature and the resulting thermal stresses, early shrinkage, and the risk or severity of transverse bridge deck cracking.

Healy and Lawrie (1998) defined the factors that control shrinkage cracking. These factors include: size of placement, time of day when placement is made, time for initiation of curing, maximum and minimum temperature where placement is made, rate of placement, design and detailing considerations, and mix design. As a result of their study, it was recommended that a comprehensive procedure be utilized, including mist spray and burlap curing with continuous wetting as the method for curing bridge decks.

Issa (1999) linked concrete cracking, and thus high magnitude of shrinkage, to a high evaporation rate resulting from inadequate concrete curing procedures during hot weather conditions. This effect is attributed to lack of concrete protection, inadequate coverage with a curing compound, and delay of concrete protection application. Kwak et al. (2000)



recommended that the slump should be less than 5 inches if the average relative humidity is 60 percent to avoid transverse cracking at interior supports with live loading.

Almusallam (2001) indicated that exposure conditions at the time of casting significantly affect the properties of both fresh and hardened concrete. The rate of water evaporation, shrinkage strain, and the area of cracks increased with increasing exposure temperature and wind velocity, and decreasing relative humidity. Plastic shrinkage cracks were noted earlier in concrete specimens exposed to elevated temperature and low relative humidity when compared to specimens exposed to low temperature and high humidity. The exposure conditions also influence the properties of hardened concrete. Elevated temperature exposure decreased the compressive strength. Moreover, the exposure conditions significantly affect the pore structure of concrete. Coarser pores were noted in the concrete specimens cast at 113°F than pores of those cast at 86°F.

#### **2.4.1 Evaporation of Water from Fresh Concrete**

Heat of hydration in fresh concrete, amount of plastic shrinkage, and plastic shrinkage cracking depend to a great extent on the rate of evaporation from fresh concrete, which influences the strength and durability of the concrete. It is recognized that the magnitude of evaporation from the surface of fresh concrete depends on the prevailing air temperature, relative humidity, wind speed, and the temperature of the fresh concrete. The evaporation rate depends on climatic conditions because at the beginning of casting, water exists at the surface of the concrete (bleeding water). Additionally, the moisture movement within the solid is rapid enough to maintain a saturated condition of the surface. The drying process of porous media can be divided into two periods referred to as initial and terminal drying period. In case of concrete, initial drying period consists of two evaporation stages. The mechanism of moisture removal during the first stage is equivalent to evaporation from a liquid water surface. The evaporation-drying rate of concrete can be calculated from heat transfer relationship (Razek and Enein 1999):

$$R_c = h_c (T_{da} - T_w) / L \quad (2-1)$$

where,  $R_c$  is the evaporation drying rate (lb/ft<sup>2</sup>/hr),  $h_c$  is convection heat transfer coefficient (Btu/ft<sup>2</sup>/hr/K) and can be calculated by relation  $h_c = 4.28 + 0.375v$  ( $v$  is the wind velocity in ft/s),  $T_{da}$  is the dry bulb temperature (ambient air temperature) (K),  $T_w$  is the wet bulb temperature (K) and can be calculated from ASHRAE Psychrometric Chart No.6 (ASHRAE Handbook 1992) by knowing relative humidity and dry bulb temperature of air, and  $L$  is the latent heat of vaporization of water (Btu/lb).

## **2.5 CONSTRUCTION RELATED FACTORS**

Construction-related factors include concrete mixing and delivery parameters, control of ambient temperature and humidity during placement, consolidation of fresh concrete, deck placement sequences, traffic-induced vibrations, construction loads, finishing procedures, and curing. Perfetti (1985) and Purvis (1989) reported that placement length and sequence did not influence transverse cracking. In contrast, some agencies recommend sequenced placements.

Purvis et al. (1995) observed the construction of eight bridge decks to identify procedures contributing to shrinkage and cracking. The general observation was that the construction procedures would not affect the performance of the eight sites observed with respect to deck cracking. During the observations, temperature was measured and shrinkage tests were conducted on the specimens to measure thermal and drying shrinkage. Based on this data, it was predicted that transverse cracks would develop in four of the eight bridge decks. Visiting the observed bridges later validated the prediction. It was concluded that these results further confirm that thermal and drying shrinkage are the primary causes of transverse cracking in bridge decks.

Krauss and Rogalla (1996) indicated that finishing procedures can affect cracking and any delay in finishing can increase cracking. They recommended that to prevent cracking, construction loads should not be allowed until the concrete has sufficiently hardened. Regarding mixing procedures, no correlation between the number of revolutions of transit mix trucks and deck cracking was found.

Similarly, Issa (1999) indicated that it is important to initiate placement in the positive moment regions prior to the negative moment regions. Traffic-induced vibrations do not cause any

damage to deck concrete that is well-proportioned and well-compacted with low slump. However, additional vibrations due to adjacent traffic and construction equipment may increase cracking in the case of under-consolidated, high slump concrete. Issa and Yousif (2000) stated that the vibration and movement imposed on the extended reinforcement is a major source of concrete bridge deck cracking.

Kwak et al. (2000) studied theoretically the effect of slab concrete placing sequence on transverse cracking of slab decks. They found that the effect of slab placement sequence is negligible for both short-term and long-term behavior of steel box girder bridges.

## **2.6 TEMPERATURE AND THERMAL STRESS DEVELOPMENT**

### **2.6.1 Overview**

This section focuses on thermal stresses as the main cause of restraint shrinkage cracking. Thermal stresses develop as the result of deck temperature changes and the restraint imposed by the girders. Very early thermal stresses develop in a bridge deck as a result of hydration temperature. The other sources of temperature changes are due to diurnal and seasonal temperatures. Thermal stresses are greatly affected by many factors such as continuity, relative deck to girder stiffness, the concrete material itself, geographic location, etc. The NCHRP report 380 developed elastic equations to predict shrinkage and thermal stresses in a bridge deck. This topic is organized in six sections. Section 2.6.2 presents the hydration temperature stresses, Section 2.6.3 presents the cause of diurnal temperature stresses, Section 2.6.4 presents the effects of seasonal temperature stresses, and finally Section 2.6.5 presents the summary factors affecting thermal stresses and precautions.

### **2.6.2 Hydration Temperature Stresses**

Hydration of cement is an exothermic process that causes a temperature rise within a concrete mass. This initial temperature rise and expansion induces no residual compressive stresses in concrete when changing from a plastic state to a solid state. This is because of the extremely low modulus of elasticity of the concrete at this plastic-to-solid state. When the concrete reaches its peak temperature, it has also solidified. Subsequently, the hardened concrete begins to cool to ambient temperature. During the cooling process, longitudinal beams restrain the deck shrinkage. This phenomenon will in turn cause tensile stresses and transverse cracking in the

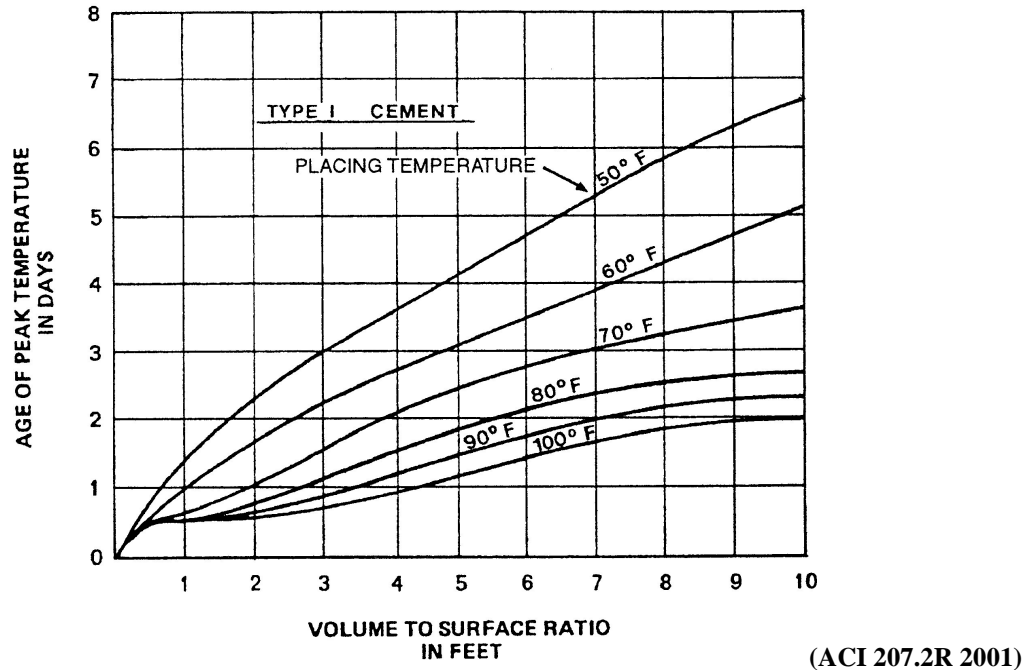
deck. The magnitude of thermal shrinkage in the deck depends on the difference between the peak concrete temperature and the temperature of supporting beams at that time. The temperature of supporting beams is usually equal to the ambient temperature, unless the deck is heated underneath as part of cold-weather curing. Unlike deck drying shrinkage, which may take over a year, thermal shrinkage affects the concrete over a short period (a few days). Thus, concrete creep properties cannot be fully used to relax the concrete and mitigate cracking. Analytical work established that 228-microstrain thermal shrinkage would be necessary to initiate cracking (Purvis et al. 1995).

Typically, for conventional concrete bridge decks cured under normal weather conditions, the amount of restrained thermal shrinkage is on the order of 170 microstrain or less, which corresponds to a differential deck/beam temperature of about 30 °F or less. This is usually not sufficient to initiate cracking (less than the threshold of 230 microstrain). However, the cracking threshold may be exceeded when the thermal shrinkage is superimposed upon the drying shrinkage (Babaei and Fouladgar 1997).

Krauss and Rogalla (1996) stated that thermal stresses from early hydration temperatures are most extreme in steel-girder bridges, and also high when the deck is cast separately over precast concrete girders. Concrete conducts less heat than steel, and the large girder mass will cause a delay in the adjustment of the girder temperature to the change in deck temperature. Steel girders typically conduct heat more quickly than concrete girders, and upper flanges will adjust to the deck temperature, reducing the temperature difference at the interface. A 50 °F temperature change in the deck relative to the girders can cause stresses greater than 200 psi when the concrete has an early effective modulus of elasticity of only  $0.5 \times 10^6$  psi, and greater than 1000 psi when the early effective modulus is  $2.5 \times 10^6$  psi.

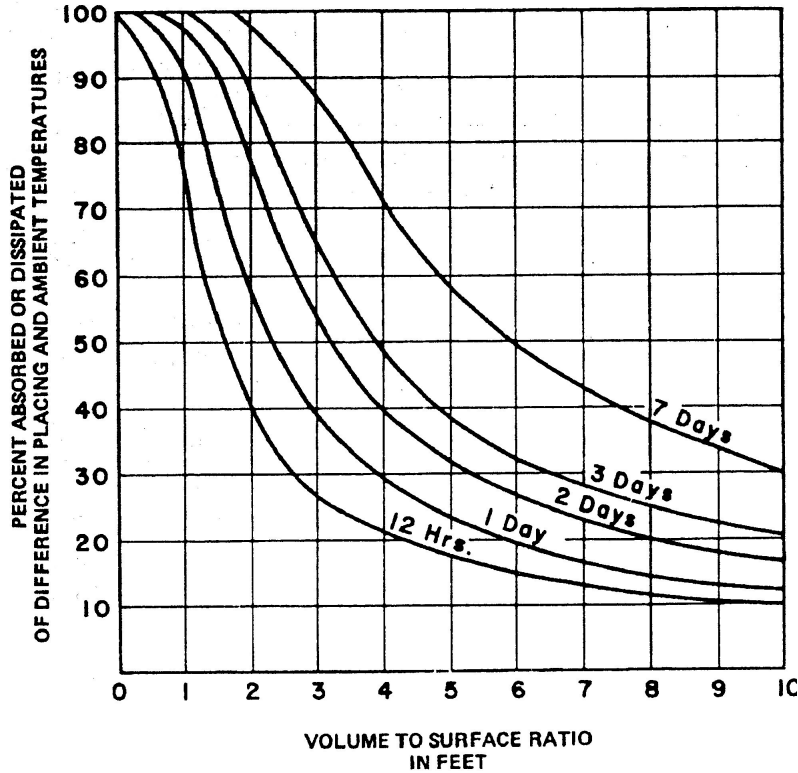
#### *2.6.2.1 ACI 207.2R Procedure for Calculating Hydration Temperature*

The rate and magnitude of concrete temperature rise during the hydration process depend on several factors. These factors include cement composition (cement type) and fineness, amount of cement per unit volume of concrete, ambient temperature, concrete placing temperature, and amount of heat lost or gained during hydration process. The exposure conditions and volume to exposed surface area ratio of bridge deck governs the amount of heat lost or gained.



**Figure 2-3. Effect of concrete placing temperature and volume to surface (exposed to environment) ratio on age at peak temperature for Type 1 cement**

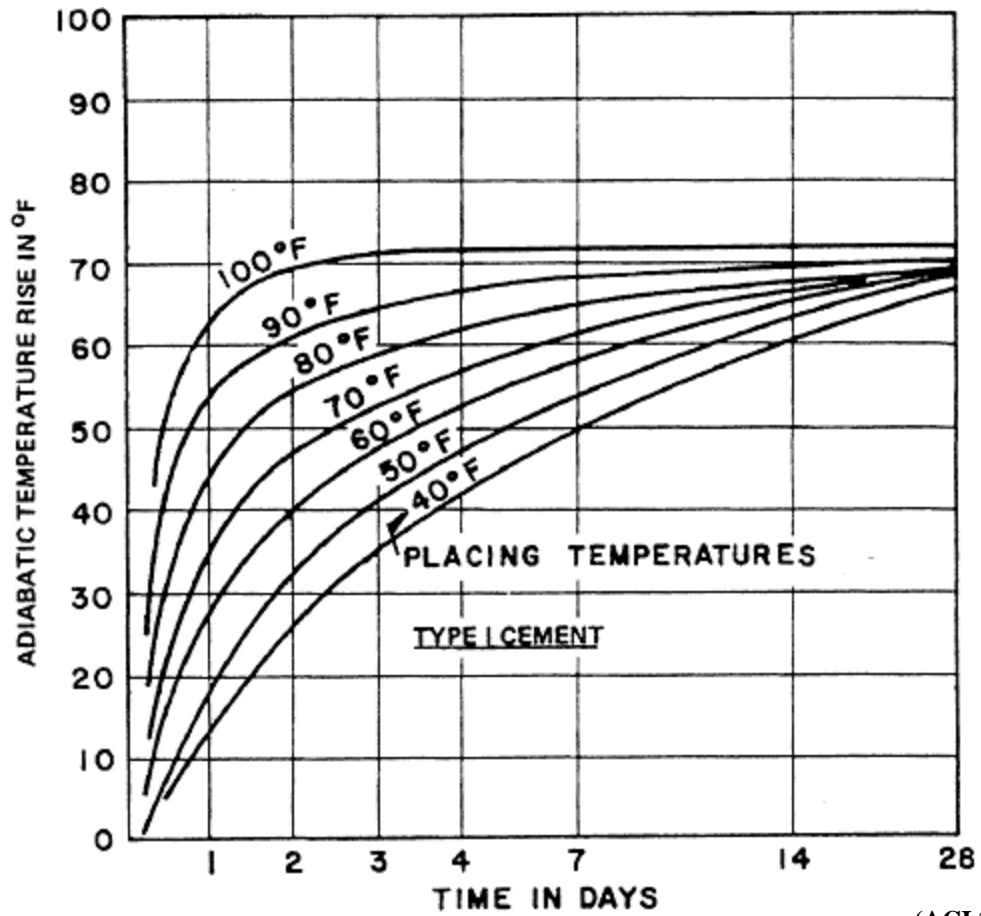
If the concrete placing temperature and volume/surface ratio of bridge deck are known, the age at which the peak temperature could be attained can be determined from Figure 2-3, provided Type 1 cement is used. During the hydration process there is a temperature difference between the deck and the ambient air. After the age at peak temperature is determined, Figure 2-4 can be used to compute the difference in percent absorbed or dissipated in placing and ambient temperature.



(ACI 207.2R 2001)

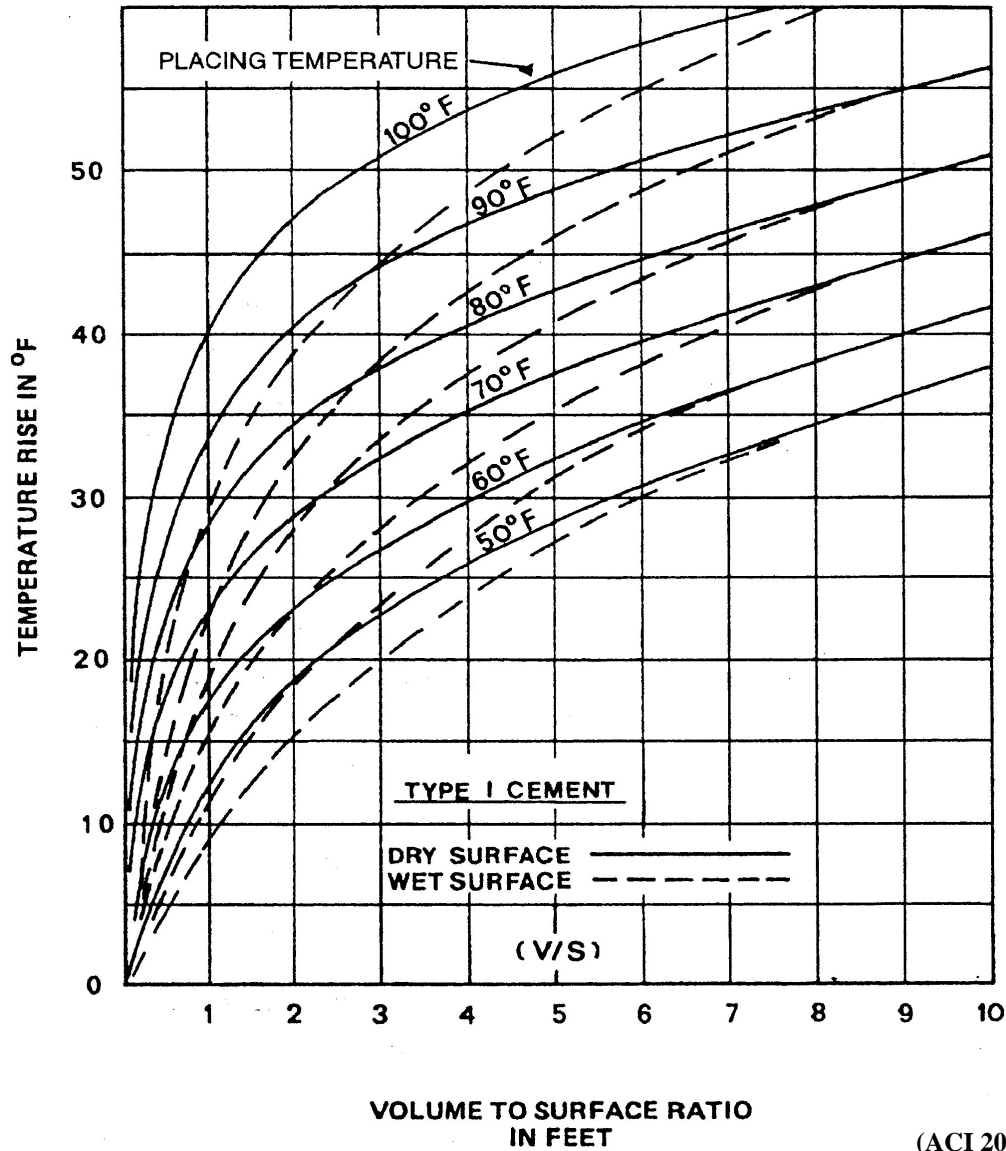
**Figure 2-4. The effect of volume to surface ratio and age at peak temperature on percent absorbed or dissipated of difference in placing and ambient temperature**

When bridge decks are considered, the volume to exposed-surface ratio ( $V/S$ ) is less than one foot. According to Figure 2-4, due to a significantly higher rate of heat absorbed or dissipated, the effective placement temperature equals ambient temperature. The placing temperature is also a parameter for adiabatic temperature rise (Figure 2-5). The temperature rise within the concrete deck also depends on the exposed deck surface condition. As depicted in Figure 2-6, if the exposed concrete surface is kept wet, the temperature rise decreases significantly.



(ACI 207.2R 2001)

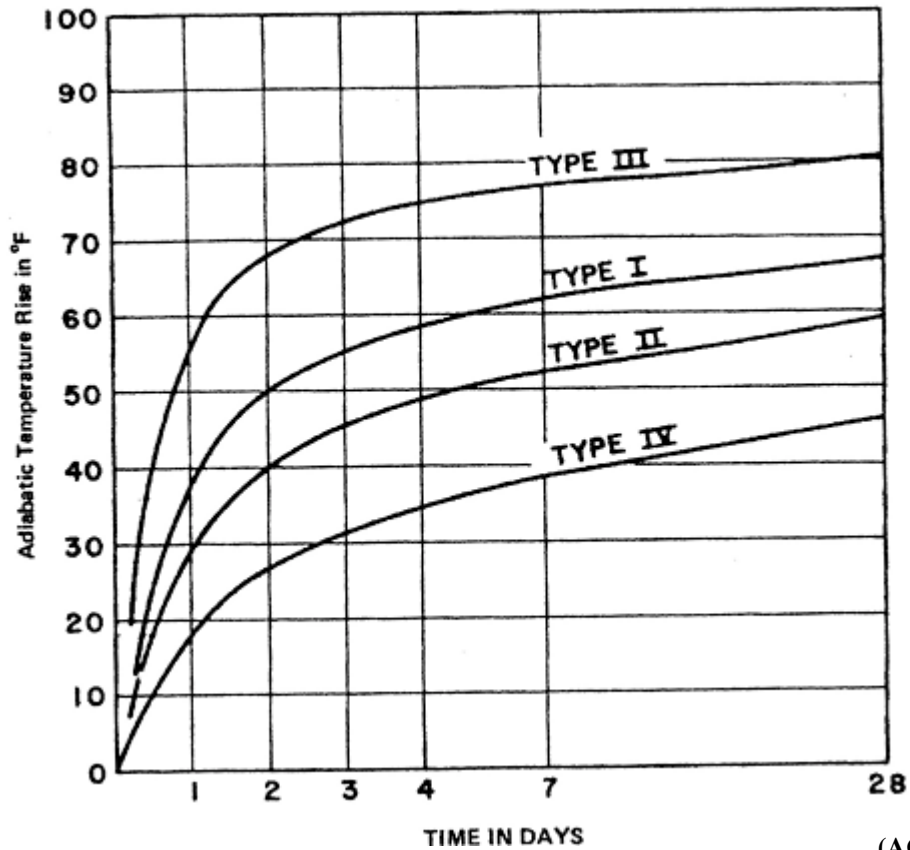
Figure 2-5. Effects of placement temperature on adiabatic temperature rise



**Figure 2-6. The effect of volume to surface ratio and exposed surface condition on temperature rise of concrete members (376 lb/yd<sup>3</sup>)**

Cement type, content, and its fineness affect the adiabatic temperature rise in a concrete element. Figure 2-7 shows the adiabatic temperature rise for different types of cements. In developing these graphs, a cement content of 376 lb/yd<sup>3</sup> was used and the respective fineness is given in Table 2-8. If cement with a different fineness is used, Figure 2-8 can be used to calculate the correction factor. In addition, the total quantity of heat generated at any age is directly proportional to the total amount of cement in the concrete mix.



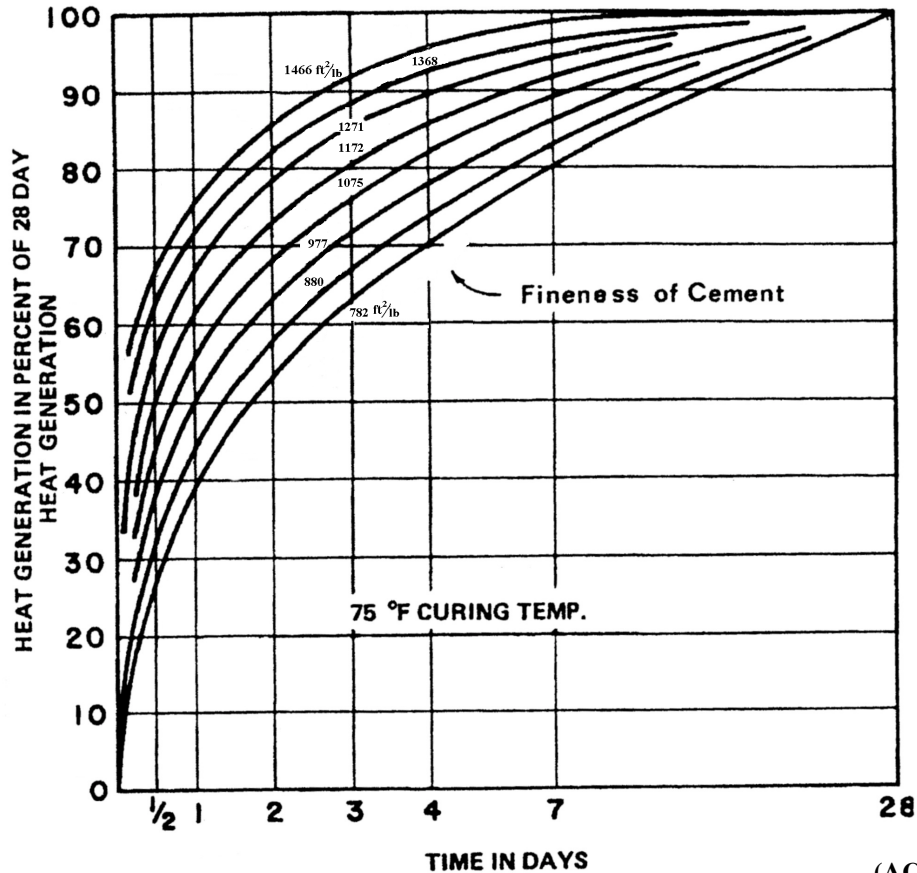


(ACI 207.2R 2001)

Figure 2-7. Variation of adiabatic temperature rise with age of concrete for different types of cements

Table 2-8. Cement Types and Fineness used for Developing Graphs in ACI 207.2R

Cement Type	Fineness ASTM C 115 $\text{ft}^2/\text{lb}$
I	875
II	924
III	992
IV	933



(ACI 207.2R 2001)

Figure 2-8. Effects of cement fineness on heat generation

### 2.6.3 Diurnal Temperature Stresses

For most bridges, diurnal temperature changes within the bridge produce the largest thermal stresses. The diurnal temperature cycle of the bridge decks usually exceeds the ambient air temperature cycle, especially on surfaces directly exposed to solar radiation. Bridge decks in moderate or extreme climates can easily experience 50°F diurnal temperature cycles. Because heat does not instantly transfer to the girders, temperature gradients usually exist within bridge decks. The parametric study conducted by Krauss and Rogalla (1996) revealed that a linear temperature gradient in the deck, not a uniform temperature gradient, typically produces the largest deck stresses and the greatest risk of transverse cracking. Diurnal thermal stresses are often larger over the interior supports of a continuous-span structure. Thermal tensile stresses above these interior supports may exceed 1400 psi with steel girders and nearly 2000 psi with concrete girders. All of these stresses are sufficient to cause transverse deck cracking, especially over the interior supports of a continuous-span structure.

#### **2.6.4 Seasonal Temperatures Stresses**

Stresses from seasonal temperature changes are small or negligible in most concrete bridges because decks and girders have similar or equal expansion coefficients. Deck stresses in concrete bridges caused by seasonal (uniform full-depth) temperature changes occur only because of expansion differences between the concrete and deck reinforcing. When steel girders support the concrete deck, seasonal temperature differences will cause thermal stresses if the concrete has a different thermal expansion rate than the steel (Krauss and Rogalla 1996).

#### **2.6.5 Summary of Factors Affecting Thermal Stresses and Precautions**

Many factors affect shrinkage and thermal stresses. The primary factors include the concrete material itself, the geometry of the bridge, construction techniques, and the environment.

Krauss and Rogalla (1996) indicated that aggregates affect shrinkage and thermal stresses, and therefore transverse deck cracking. Aggregates with a lower modulus of elasticity reduce the modulus of elasticity of concrete, and therefore reduce shrinkage and thermal stresses. These aggregates also often increase creep, further reducing shrinkage stresses. Thermally conductive aggregates may reduce thermal gradient within the deck, lowering thermal stresses. Increasing the aggregate content can reduce the concrete coefficient of thermal expansion by reducing the more thermally expansive paste content. Using concrete with a lower coefficient of thermal expansion will reduce the thermal stresses.

Babaei and Fouladgar (1997) recommended that thermal shrinkage should be limited to 150 microstrain. This can be achieved by maintaining the concrete/deck differential temperature to less than 22°F for at least 24 hours after the concrete is placed. It was also recommended that the following procedures be followed to control thermal shrinkage:

- Use of cement content as low as possible, such that lower heat of hydration is generated.
- Use of Type II cement instead of Type I cement, in order to reduce the heat of hydration.
- Examination of the cement chemistry, since for a given type of cement, some brands may generate a higher heat of hydration due to their chemical and physical properties.

- Use of retarders in the mix, because they delay the hydration process and reduce the difference of temperature within the concrete and the ambient temperature.
- Use of pozzolans and slag as a partial substitute for Portland cement.
- Protection of the concrete from solar radiation to reduce the temperatures due to hydration and insulation of the bridge to reduce the rate of cooling.

## **2.7 SHRINKAGE EFFECTS ON DECK CRACKING**

### **2.7.1 Overview**

Transverse cracking of concrete decks takes place at early ages, some immediately after construction or during some period of time thereafter. Cracking at early ages may be expressed in terms of the volume change of concrete. One of the important volume change effects in concrete at early ages is shrinkage. There are four types of shrinkage that take place in concrete. They are evaporation, drying, autogenous, and carbonation shrinkage.

As concrete hardens, evaporation shrinkage occurs. Concrete is a plastic material when it is fresh. Hardening of concrete is due to hydration of cement. This hydration process increases the concrete mass to a certain temperature. Meanwhile, the surface of the deck is subjected to environmental effects such as high or low temperatures, evaporation, etc. These external effects cause thermal stresses due to evaporation cooling of water in concrete. The amount of stress developed by the evaporation shrinkage is related to ambient and concrete temperatures. Greater temperature differences between the concrete surface and its surrounding environment cause a considerable amount of evaporation shrinkage (Kovler 1996).

Autogenous shrinkage is associated with the loss of moisture from capillary pores of concrete due to hydration of cement. Since the autogenous shrinkage is related to cement hydration, higher cement content, water/cement ratio, cement paste volume, and rate of hydration of cement are important (Mokarem et al. 2003 and Bissonette 1999). It is important to know the difference between drying shrinkage and autogenous shrinkage in order to understand the effects of both parameters, since they occur simultaneously. Drying shrinkage can be expressed as the loss of absorbed water from capillary pores of concrete due to environmental effects (Alsayed et al. 1998). Macro and micro-diffusion and moisture distribution in concrete are important factors in

drying shrinkage. Macro-diffusion is the movement of water through the path of least resistance. This movement takes place in larger pores available in concrete. Micro-diffusion is the movement of water and/or moisture between capillary pores and gel pores. This movement of water in pores has an effect on concrete deformation (Mokarem 2002).

Carbonation shrinkage occurs at the surface of concrete members. The existence of carbon dioxide and humidity in the environment cause carbonation shrinkage. Carbonation reaction occurs during a long period of time, thus is not an issue for early-age deck cracking. The carbonation shrinkage amount and resulting defects are relatively small compared to other shrinkage types and age of concrete (Mokarem 2002).

## **2.7.2 Factors Affecting Shrinkage**

Factors affecting shrinkage can be classified as controllable and uncontrollable parameters. Controllable parameters are cement type, aggregate, water content, and construction practices. Uncontrollable parameters are environmental factors and material properties.

### *2.7.2.1 Cement Type and Content*

High strength concrete develops higher strength than normal strength concrete at early ages. Shrinkage in high strength concrete generates more strain than normal strength concrete because high strength concrete contains more cementitious material and better aggregate grading. The shrinkage rate of normal strength concrete is less than that of high strength concrete (Altoubat et al. 2001, Samman et al. 1996 and Wiegrink et al. 1996).

Cement composition controls many properties of concrete such as strength, durability, and stability for a given aggregate and cement. Therefore, cement composition cannot be disregarded when analyzing the durability of concrete. Concrete is composed of cement paste and aggregate. Concrete contains aggregate as approximately 70% of its volume; this aggregate acts mainly as a passive filler material. However, cement paste is responsible for the quality of concrete. The Ordinary Portland Cement (OPC) that is available in the market is much finer in specific surface than the cements used two decades ago. Cement technology has undergone significant changes in the world during the last two decades. Today's cement contains more  $C_3S$  and less  $C_2S$  when compared to the old cements. Therefore, rapid compressive strength gain is

observed. New cement requirements are different from old cements with respect to quantity and water demand. OPC consumes less water, but generates more heat of hydration, since it has a finer surface and higher C<sub>3</sub>S content (Uzzafar 1992). Krauss (2003) reports similar consequences of new cements. In order to draw conclusions about the effect of cements on early-age cracking, old and new cement properties are compared. Old cements have more coarse particles and lower early-age strengths than OPC. It is obvious that OPC's shrinkage tendencies will be different due to its fineness and early-age strength as shown in Table 2-9 (Krauss 2003).

**Table 2-9. Change of Cement Properties and Strength**

Cement Properties					Compressive Strength (psi)				
Type	Composition (% by weight)				Fineness (ft <sup>2</sup> /lb)	1 Day	3 Day	7 Day	28 Day
	C <sub>3</sub> S	C <sub>2</sub> S	C <sub>3</sub> A	C <sub>4</sub> AF					
<b>1994</b>									
<b>I</b>	51.8	18.2	10.6	7.4	1826	2485	3760	4620	5605
<b>II</b>	54.9	17.3	7.1	10.6	1855	2463	3850	4786	5570
<b>III</b>	51.7	18.0	10.4	6.9	2661	3981	5167	5923	6782
<b>IV</b>	42.2	31.7	3.7	15.1	1655	900	1725	2529	5417
<b>1950</b>									
<b>I</b>	44.6	27.4	11.2	8.3		520	1610	2760	4450
<b>II</b>	43.6	30.9	5.2	13.2		520	1400	2140	3790
<b>III</b>	52.9	18.6	10.5	9.5		1530	3680	5080	6340
<b>IV</b>	27.6	48.9	4.4	12.3		240	740	1220	2830

The effect of cement on concrete shrinkage is a complex topic that is still being investigated. For instance, some researchers state that cement properties have little or no effect on concrete shrinkage for a given amount of cement (Li et al. 1999). Furthermore, Mehta (1986) states that cement fineness and composition have an effect on the hydration process but not on hydration products, so the cement fineness and composition change have a slight effect on cement mortar. In terms of concrete shrinkage, those effects are negligible due to their insignificance. On the contrary, ACI 224.R-01 (2001) states that cement properties have a direct effect on concrete shrinkage. Neville (1995) states that higher shrinkage of cement does not result in higher concrete shrinkage. The chemical composition of cement is believed to be ineffective to concrete shrinkage. On the other hand, the ACI 224 committee report states that finer cements

generally cause increased shrinkage in concrete, but the increase in fineness is not proportional to shrinkage.

An advantage of coarse cement particles is that they generate relatively less shrinkage when compared with finer cements. On the other hand, coarser cement requires a longer curing period to avoid low strength development, larger pores, and high porosity (Bentz et al. 1999).

Cements that have lower  $C_3A/SO_3$  ratios, lower alkalinity, and higher  $C_4AF$  contents shrink less. Changing the cement type is another means of reducing shrinkage. As mentioned earlier, Type II cement has a tendency to generate lower shrinkage when compared with Type I cement (ACI 224.R-1 2001)

The ambiguity of pozzolans is another topic to be discussed. For instance, Neville (1995) states that mineral additions such as fly ash and slag increase the shrinkage. Specifically, higher proportions of mineral admixtures in blended cements lead to higher shrinkage. On the other hand, ACI 224 states that the use of mineral admixtures could increase the mixing water requirement, thus increasing the water/ cementitious material ratio. This increase in water does not necessarily mean an increase in shrinkage (ACI 224.R 2001). Research showed that pozzolans have a positive effect on shrinkage. Li et al. (1999) states that ground granulated slag and silica fume blend could result in better performance and less shrinkage than OPC silica fume concrete.

The most commonly used cement replacement pozzolan is fly ash. The use of fly ash in concrete has many different advantages such as an increase in long-term strength and durability. On the contrary, disadvantages of the use of fly ash are an increase in autogenous shrinkage and variable permeability depending on the type of fly ash used (Naik et al. 1995). Swamy (1997) states that if satisfactory curing can be performed in the field, early-age autogenous and long-term drying shrinkage will be less than that of OPC concrete.

Adding silica fume at about 10% of cement weight could reduce long-term drying shrinkage as well as help in the treatment of insufficient curing duration problems. This replacement reduces the long-term drying shrinkage strain in both laboratory and field cured concrete specimens (Alsayed 1998). On the other hand, silica fume addition will strongly affect the autogenous

deformation and relative humidity change in concrete. The hydration reaction of silica fume has a heat sensitivity that is markedly different from cement hydration (Jensen 1999). As a general concept, adding some amount of micro silica often results in better performance in severe environments (Sabir 1997).

Pozzolans may also be used in the production of blended cements. Blended cement production is common in Europe and Asia. The research focusing on durability and shrinkage performance of concrete concluded that the blended cements perform better than OPC. A number of disadvantages of ordinary Portland cement can be overcome by using additional pozzolans such as fly ash, slag, and silica fume. Blended cements give users a chance to enhance cement performance when considering the harsh environments to which concrete will be subjected (Malhotra et al. 1995 and Nehdi 2001). Swamy (1989) states that the use of appropriate blended cement and high range water reducer is one of the most durable design considerations for concrete in severe environments.

#### *2.7.2.2 Water/Cement Ratio*

Some researchers focus on the role of water content of mix design in shrinkage. The U.S. Bureau of Reclamation test results showed that any increase in the amount of water content results in an increase in shrinkage. Reduction in concrete shrinkage is possible by keeping the water content to a minimum and total aggregate content to as high a level as possible (ACI 224-R-1 2001). On the other hand, some recent research findings show that lowering the water content could increase the concrete shrinkage (Igarashi et al. 2000, Samman et al. 1996, and Wiegrink et al. 1996). Mehta (1986) states that for a given cement content, an increase in water content increases the shrinkage. Similarly, for a given water/cement ratio, an increase in cement content also increases the shrinkage. Those results are expected due to increase in the amount of cement paste, but in practice they do not always occur. There is a need to have a better understanding of the role of water in concrete shrinkage. It appears that an optimum value of water/binder ratio could be determined for less shrinkage of concrete. Bissonnette et al. (1999) suggests an optimum water/cement ratio range of 0.35-0.50 and found a strong relationship between cement paste volume and shrinkage amount.



### *2.7.2.3 Aggregate Type and Fine Aggregate to Coarse Aggregate Ratio*

Cement is considered to be the source of shrinkage in concrete. Shrinkage develops tension on the binder (cement) and compression on the aggregate. The amount of tension and compression is related to the age of concrete, curing, and mechanical properties of the coarse aggregate. If the mechanical properties of coarse aggregate are poor, then compression will cause a volume change in the aggregate. This volume change will also affect the concrete integrity by contributing to further shrinkage. In the same manner, the amount of coarse aggregate causes internal restraint to shrinkage. The volume of cement paste is a factor for shrinkage (Bissonnette et al. 1999). Mehta (1986) describes that elastic modulus of aggregate has a greater effect than shape and size of aggregate. Additionally, aggregate density that is related to the porosity of aggregate is a good parameter to be checked for the control of shrinkage. As a general concept, shrinkage compensating concrete mixes that consider the above parameters are preferred (Altoubat et al. 2001).

### *2.7.2.4 Curing and Drying Shrinkage*

Curing has a direct impact on drying shrinkage of concrete members. Type and duration of curing are other factors. Moist curing has not been found to be sufficient in reducing drying shrinkage, whereas steam curing reduces the concrete shrinkage (ACI 224.R-01 2001). Depending on the curing conditions, approximately 66% of total shrinkage may be reached in the first three months after concrete placement (Alsayed 1998).

Sealing of concrete with a curing compound that forms an impervious membrane could reduce the drying shrinkage, but it will not eliminate the autogenous shrinkage (Altoubat et al. 2001). Silane treatment of concrete members in the field shows a resulting decrease in drying shrinkage. Therefore, this treatment should be considered in curing practices (Xu et al. 2000).

### *2.7.2.5 Relative Humidity*

Microdiffusion from the pores of concrete is a time dependent process that takes place over a long period. The field tests performed over a wide range of mix designs for 20 years of monitoring showed that 20 to 25% of 20 year drying shrinkage was realized in 2 weeks, 50 to 60% in 3 months, and 75 to 80% in one year. An increase in the atmospheric humidity is expected to slow down the relative speed of diffusion. The Committee of European Concrete

Institute (CEB) states that at 100% relative humidity drying shrinkage is assumed to be zero. When relative humidity is about 80%, the expected drying shrinkage is about 200 microstrain, and for 45% relative humidity it is about 400 microstrain (Mehta 1986). In the same way, Bissonette et al. (1999) states that relative humidity in the range of 48 – 100 % is inversely proportional to the drying shrinkage.

#### *2.7.2.6 Influence of Concrete Element Shape and Size*

Since the diffusion of water in concrete to the environment is a function of humidity, the length of the path will control the rate of reaction traveled by water. For constant humidity, both the size and the shape of a concrete element determine the amount of drying shrinkage (Mehta 1986). Distress evaluations of field specimens proved that the size of a concrete member significantly affects shrinkage. If the volume to surface ratio is greater, less shrinkage can be expected (Bissonnette et al. 1999).

#### *2.7.2.7 Effects of Restraint*

If the shrinkage of concrete occurred uniformly due to loss of water, and curing with no restraints, concrete would not crack. However, concrete is always subjected to some restraint either by the presence of aggregate and/or reinforcing steel or by non-uniform shrinkage (ACI 224.R-01 2001 and Gilbert 2001).

Restraint of concrete gradually increases the tensile stress in concrete and the resultant stress causes time-dependent cracking of decks. These existing restraint cracks widen due to flexural effects and deflections increase with time. Since the designers do not consider shrinkage and shrinkage cannot be modeled in current design procedures, restraint shrinkage will be a challenging issue for concrete structures (Gilbert 2001).

The effects of restraint on cracking will be dealt with in significant detail later in the section entitled “Parameters Influencing Deck Cracking”.

## **2.8 ANALYSIS OF CRACK FORMATION**

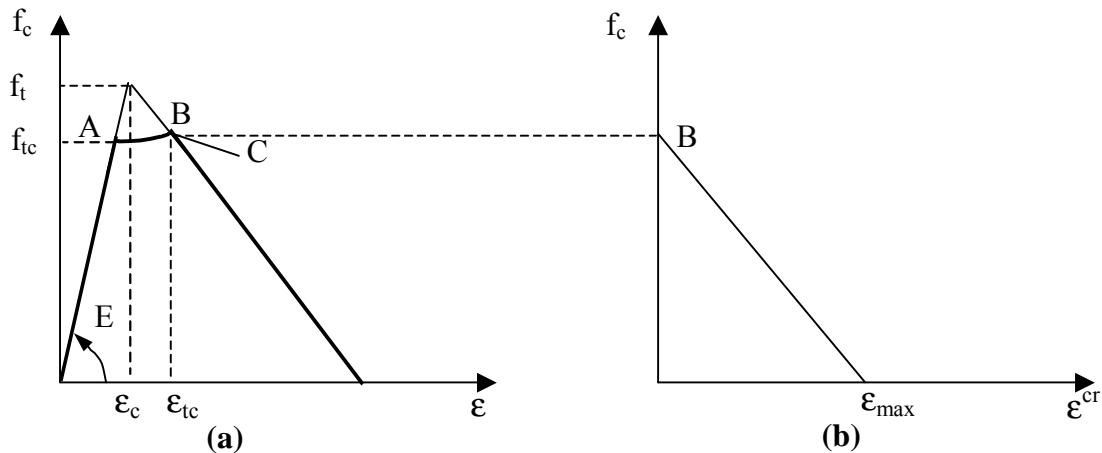
Long-term effects to crack initiation are investigated by Borst and Berg (1986). Although the study focused mainly on the creep effect, it enables the understanding of the cracking mechanism in concrete. It is discussed that in earlier research, the concrete stiffness is underestimated by

assuming it to be zero upon cracking. In order not to misjudge the concrete stiffness after cracking, a smeared finite element model is utilized in the analysis, which is established by combining cracking with inelastic concrete behavior between the cracks.

In the smeared crack model, total strain is modeled as a combination of the concrete strain and the crack strain. Concrete strain and similarly crack strain may be decomposed further into several components. In the model, shear and normal stresses on cracked concrete are derived with respect to normal and shear strains. The instantaneous concrete moduli and relaxation effects are also incorporated in the model. Shear crack strain is included by using rotation matrices to convert from local coordinates to global coordinates (Borst and Berg 1986).

According to Borst and Berg (1986), cracking due to time dependent effects such as creep, thermal dilatation, and shrinkage may not be explained only by the stress-strain relation. The cracking stress-strain concept, which is generally used, fails to explain the cracking due to the stresses below the cracking strength of the concrete. Therefore, to derive a more realistic solution, a stress-strain envelope shown in Figure 2-9 (a) is generated by joining the concrete strain from the linear-elastic model and normal strain due to cracking shown in Figure 2-9 (b). Any combination of stress and strain in the principal directions on the envelope generates cracking (Borst and Berg 1986). When a specimen is loaded such that the stress reaches the amount indicated by point A, path AB shown in Figure 2-9 (a) is followed. The concrete cracking initiates at point B.

Borst and Berg (1986) conclude that long-term cracking cannot be explained by basic stress criterion. When a combination of normal stress ( $f_c$ ) and normal strain ( $\epsilon$ ) reaching the envelope is achieved, cracking initiates. As noted in Figure 2-9,  $f_c$  is the tensile stress,  $f_t$  is the tensile strength of concrete,  $E$  is the elasticity modulus,  $\epsilon$  is the strain normal to the cracking plane measured before cracking,  $\epsilon_c$  is the strain of concrete at the tensile strength of concrete,  $f_{tc}$  is the cracking strength (80% of ultimate tensile strength of concrete),  $\epsilon_{tc}$  is the cracking strain, and  $\epsilon^{cr}$  is the strain normal to the cracking plane measured after cracking. It is also stated that a more elaborate nonlinear stress-strain relation would be more accurate rather than the linear relation used in the model.



**Figure 2-9. (a) Stress-strain envelope for cracking of concrete and (b) stress-normal crack strain after crack initiation (assuming linear-elastic behavior)**

## 2.9 CONCLUSIONS AND THE NEED FOR FUTURE RESEARCH

Early-age bridge deck cracking is the most detrimental effect on bridges reported by all of the State DOTs. Although there have been many studies on the cause of early-age deck cracking, the problem still exists. This indicates the need for more research and investigation to solve this problem.

The restrained thermal and shrinkage effects coupled with construction practices are the main parameters in need of investigation.

The early-age deck cracking due to restraint thermal stresses can be controlled by maintaining the concrete/deck differential temperature under 22°F for at least 24 hours after the concrete is placed. These recommendations are for directly impacting the crack reduction on concrete bridge decks. However, before each recommendation is implemented a comprehensive review should be made and the cost should be evaluated. It is recommended that the following changes be implemented to control thermal and shrinkage effects on deck cracking:

1. Use of cement content as low as possible (Purvis et al. 1995, Krauss and Rogalla 1996, Babaei and Fouladgar 1997, French et al. 1999, Mehta et al. 1994, ACI 211.1-97 2001, and ACI 207.2R 2001).

2. Use of Type II cement instead of Type I cement, in order to reduce the heat of hydration (Purvis et al. 1995, Babaei and Fouladgar 1997).
3. Use of a cement brand whose chemistry generates a lower heat of hydration and therefore lower shrinkage due to its chemical and physical properties (Babaei and Fouladgar 1997).
4. Use of retarders in the mix, because they delay the hydration process and reduce the temperature difference between the concrete and the ambient temperature (Purvis et al. 1995, Babaei and Fouladgar 1997).
5. Use of pozzolans and slag are recommended as a partial substitute for Portland cement. The blended cements perform better than ordinary Portland cement (OPC). Blended cements give users a chance to enhance cement performance when considering the harsh environments to which concrete will be subjected (Babaei and Fouladgar 1997, Malhotra et al. 1995, Nehdi 2001, Li et al. 1999, ACI 212.3R-96 2001, and ACI 207.2R 2001).
6. Use of optimum water/cement ratio range of 0.35 to 0.50. This range agrees with the MDOT specifications (Babaei and Fouladgar 1997, Bissonnette et al. 1999, and ACI 211.1-97 2001).
7. Protection of concrete from solar radiation to reduce the temperatures due to hydration as well as insulation of the bridge to reduce the rate of cooling (Purvis et al. 1995, Babaei and Fouladgar 1997, Issa 1999, Almusallam 2001, and Razeq and Enein 1999).
8. Placement of concrete at night in hot weather (Purvis et al. 1995, Krauss and Rogalla 1996).
9. Use of correct type and duration of curing to improve concrete durability (Issa 1999, Almusallam 2001, Day 1999, Aitcin 2003, Healy and Lawrie 1998, Swamy et al. 1986, and Swamy 1997).
10. Avoidance of vibration due to adjacent traffic and construction equipment because it may increase cracking in the case of under-consolidated, high-slump concrete. Vibration and movement imposed on the extended reinforcement are major sources of cracking in concrete bridge decks (Issa 1999, Issa and Yousif 2000).

### 3 MULTI-STATE SURVEY

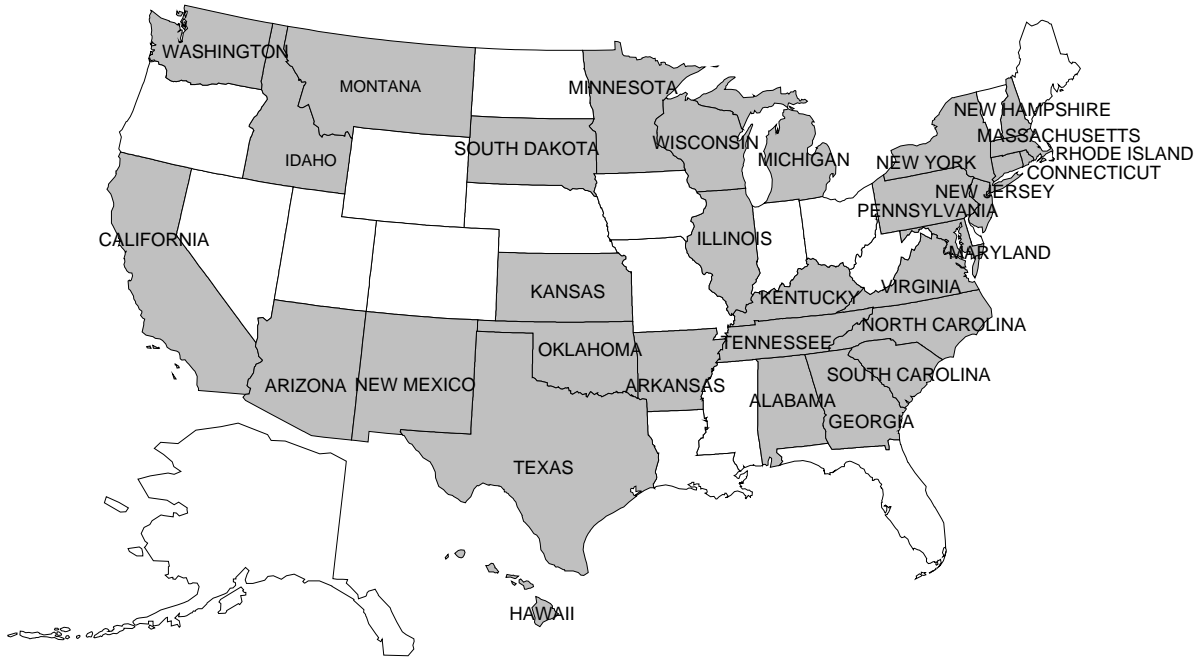
#### 3.1 OVERVIEW

A nationwide survey on the experience of other states with the problem of early-age reinforced concrete (RC) bridge deck cracking was administered after reviewed and approved by the Research Advisory Panel (RAP) members. The survey was sent to the State DOTs in November 2002. Thirty-one State DOTs responded to the survey, giving a response rate of 62 percent. The response rate is satisfactory considering an average response rate of 20% is reported for most surveys. The survey was first administered by e-mail, requesting a web submission. After 60 days, personalized e-mails and letters were sent to each non-responding agency. The responses were received through email, fax, and postal mail. The list of respondents is shown in Table 3-1.

**Table 3-1. List of Respondent States and Media of Response**

Media of Response	Respondent States
Web Submission	Alabama, Arkansas, Connecticut, Georgia, Hawaii, Idaho, Kansas, Kentucky, Massachusetts, Michigan, Montana, New Hampshire, New Jersey, North Carolina, New Mexico, Pennsylvania, Rhode Island, South Carolina, South Dakota, Tennessee, Texas, Virginia, Washington, Wisconsin
Fax	Arizona, California, Minnesota, New York
Postal Mail	Illinois, Maryland, Oklahoma

In order to represent the geographic location of the responding states, the exposure map is given in Figure 3-1.



**Figure 3-1. States who responded to the survey**

### 3.2 ANALYSIS OF SURVEY DATA

Upon compilation of the survey data, an analysis has been performed. Summaries of the responses are presented in the following figures.

It has been found that 30 of 31 responding states (97%) have the problem of early-age deck cracking except Hawaii (Figure 3-2). Twenty-five states reported having experienced cracking during the first few months of service, while 11 responded as during the first year of service. Twenty-nine states (78%) identified the mode of cracking as transverse and six states (16%) as longitudinal.

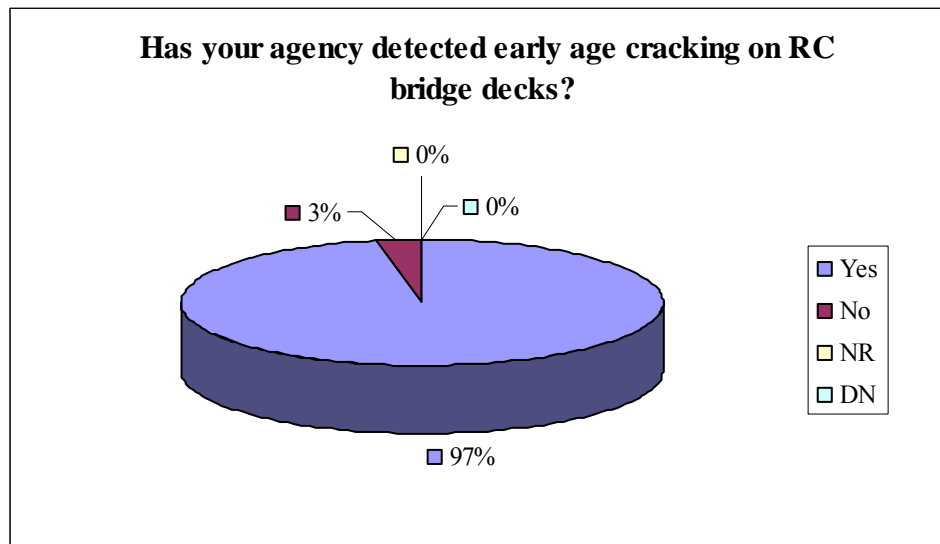
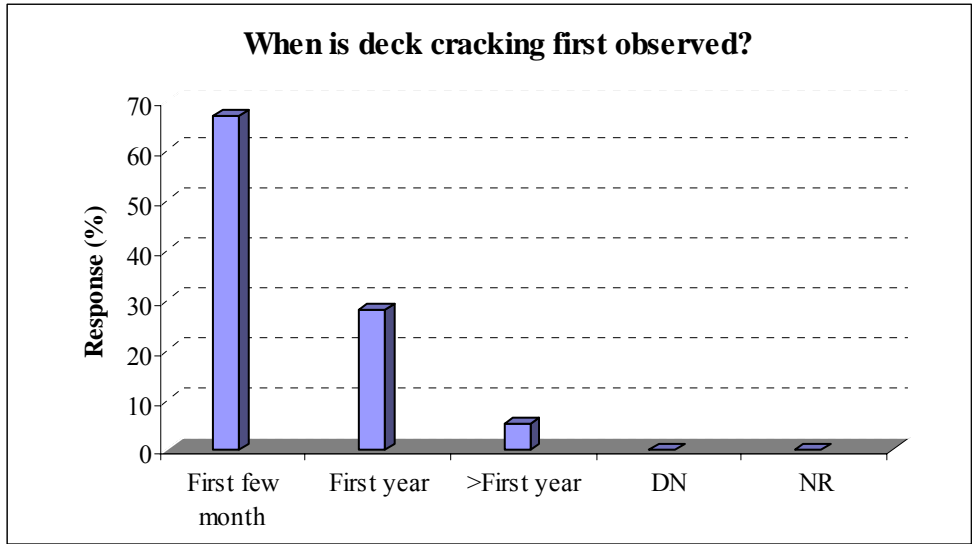
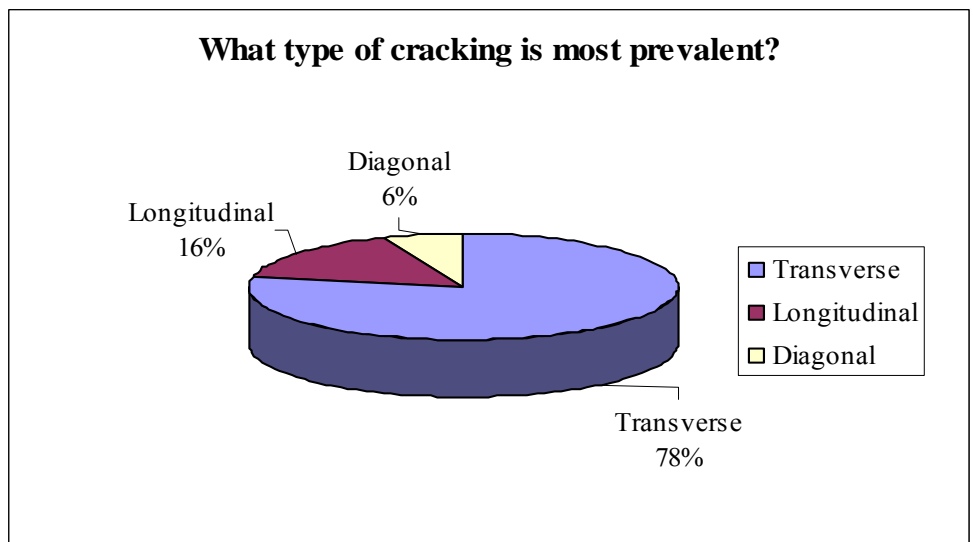


Figure 3-2. Frequency of early-age cracking observed on decks



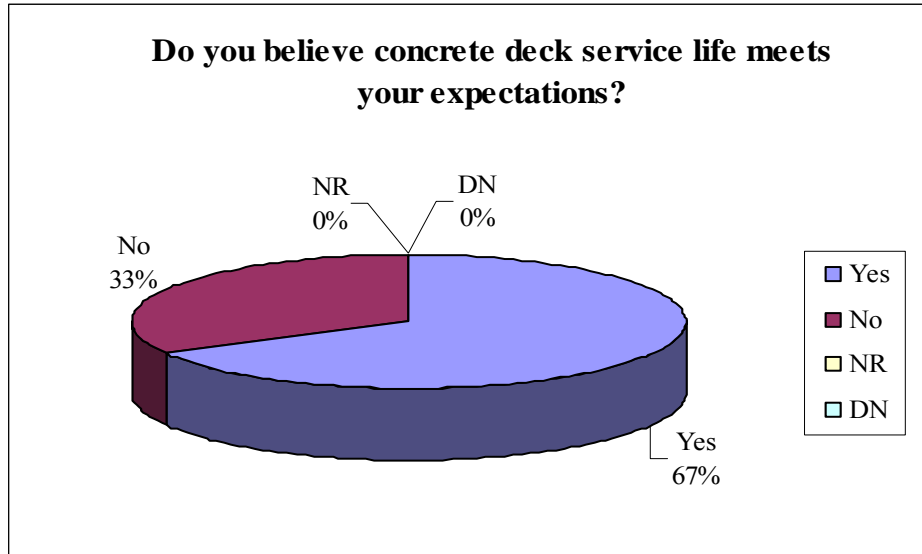


**Figure 3-3. Frequency of cracks observed during different ages of bridge decks**

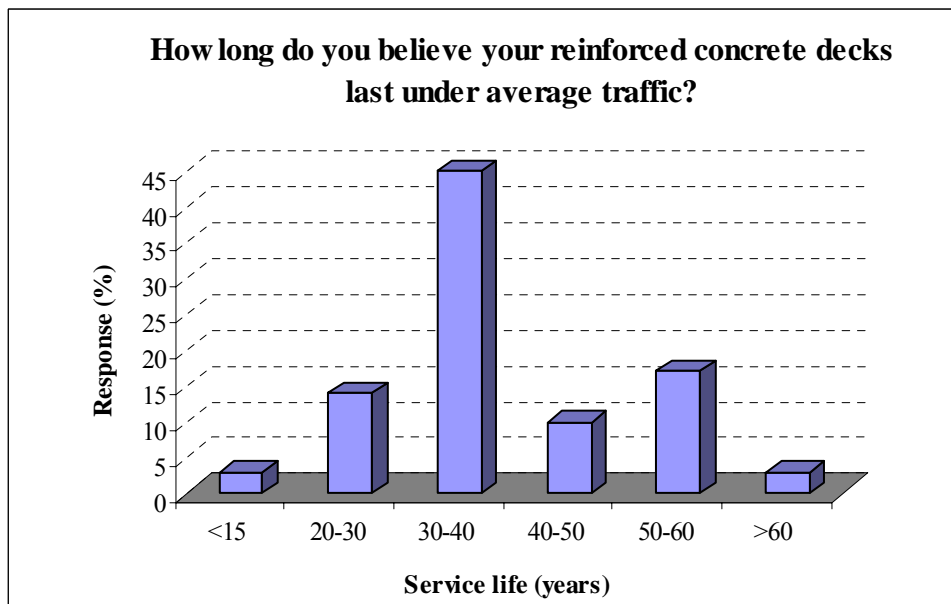


**Figure 3-4. Frequency of crack types observed on bridge decks**

Sixty-eight percent of the respondents reported that they are satisfied with the service life of concrete bridge decks under their jurisdiction. Most states identified the duration of service life of the RC bridge deck ranging from 15 to 60 years. As shown in Figure 3-6, 52 percent of the respondents identified the average service life as 30 to 40 years.



**Figure 3-5. Expectations on bridge deck service life**

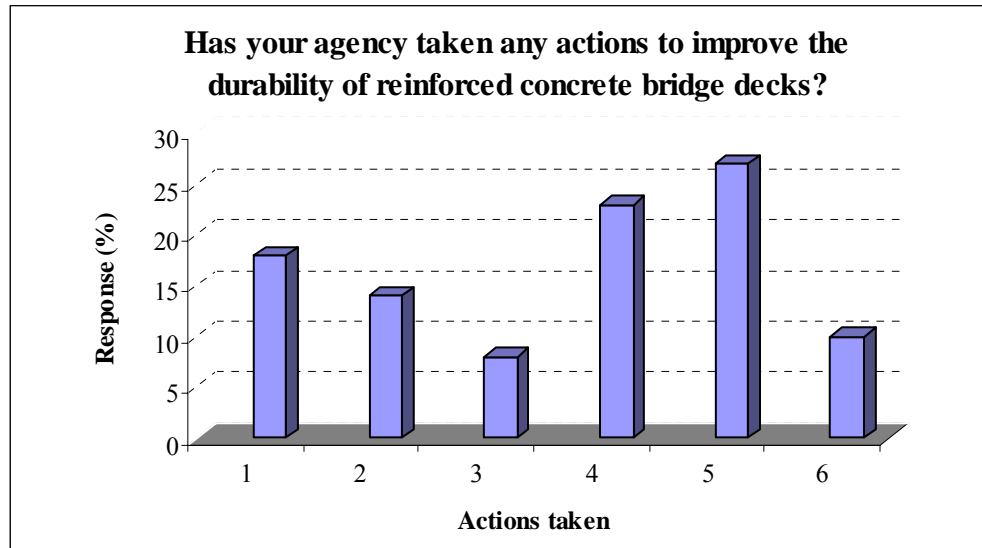


**Figure 3-6. Frequency of expected service life of bridge decks under average traffic**

After compiling the responses to Question 3 (Figure 3-7), the most prevalent actions taken to improve the durability of bridge deck are:

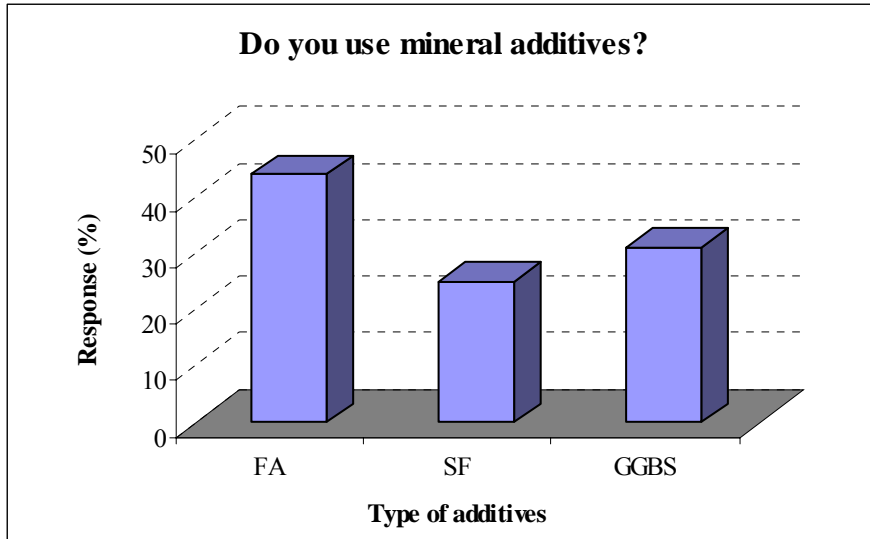
1. Increased reinforcement cover
2. Changed material
3. Changed reinforcement design

4. Changed mix design
5. Changed curing procedure
6. Increased deck thickness

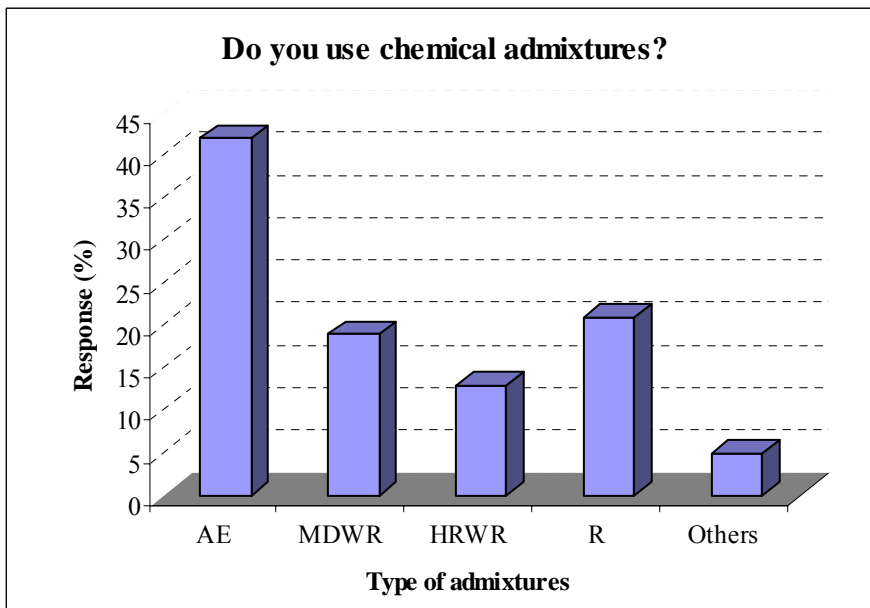


**Figure 3-7. Frequency of different actions taken to improve bridge deck durability**

The most commonly used mineral additives are fly ash (FA), silica fume (SF), and ground granulated blast-furnace slag (GGBS). Most of the states are using air entrainment (AE) and set controlling (R) admixtures. Some states are using mid range (MRWR) and high range (HRWR) water reducers. The percent of usage of different types of mineral additives and chemical admixtures among the responding states are shown in Figure 3-8 and Figure 3-9.

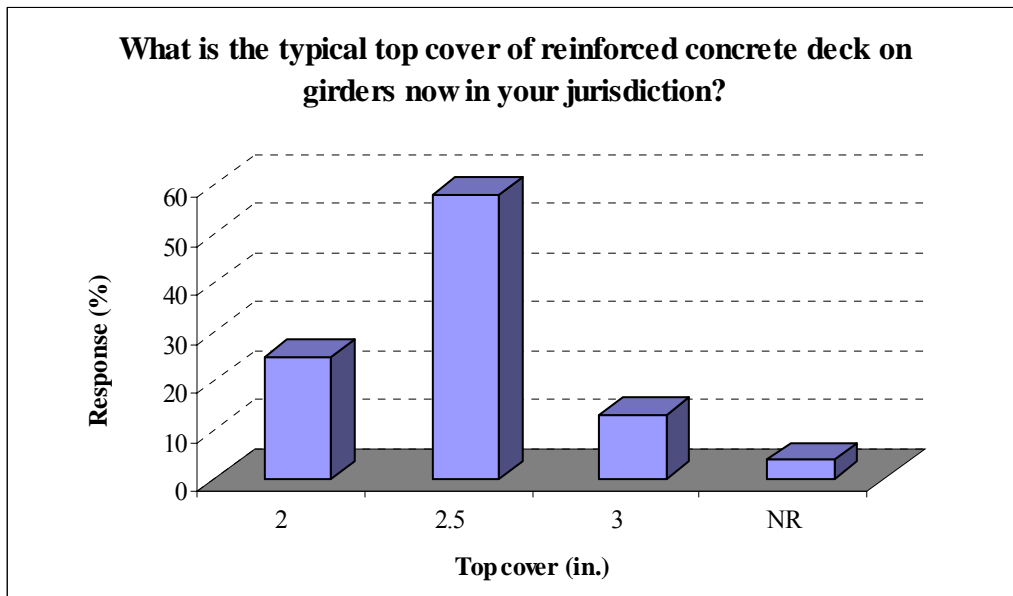


**Figure 3-8. Frequency of using different types of mineral additives in concrete mix**

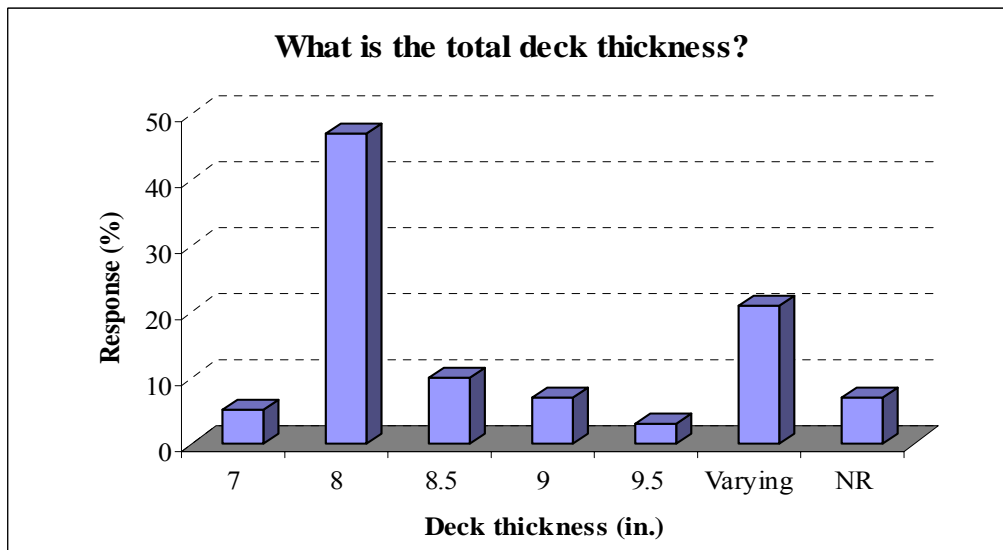


**Figure 3-9. Frequency of using different types of admixtures in concrete mix**

According to the survey response to Question 4 (Figure 3-10), the most commonly used top cover of RC bridge decks is 2.5 inches. There are a few states using 2- or 3-inch cover. Total deck thickness has varied from state to state ranging from 7 to 10.5 inches. A majority (92 %) indicated that different depth for top cover and total deck thickness have been used in the past. Most of the respondents have no knowledge of historical deck standards for top cover and total deck thickness.



**Figure 3-10. Frequency of using different top cover on reinforced concrete decks**



**Figure 3-11. Frequency of using different total deck thicknesses for bridge decks**

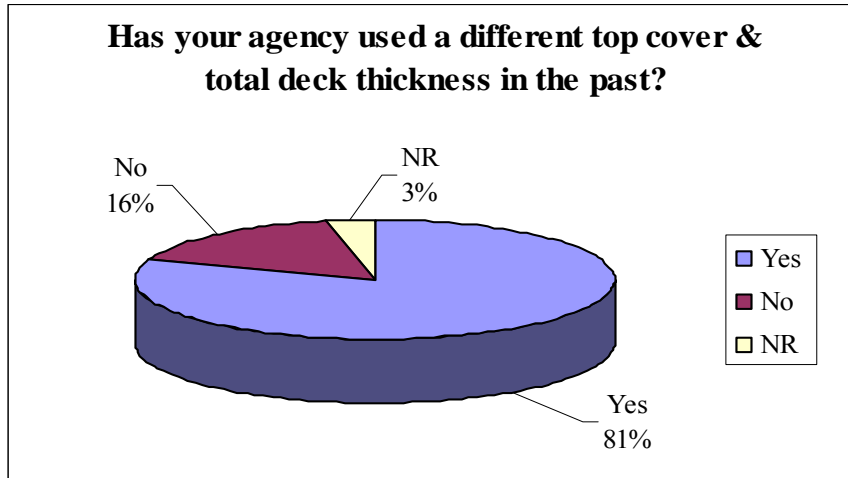


Figure 3-12. Frequency of using different top cover and total deck thickness in the past

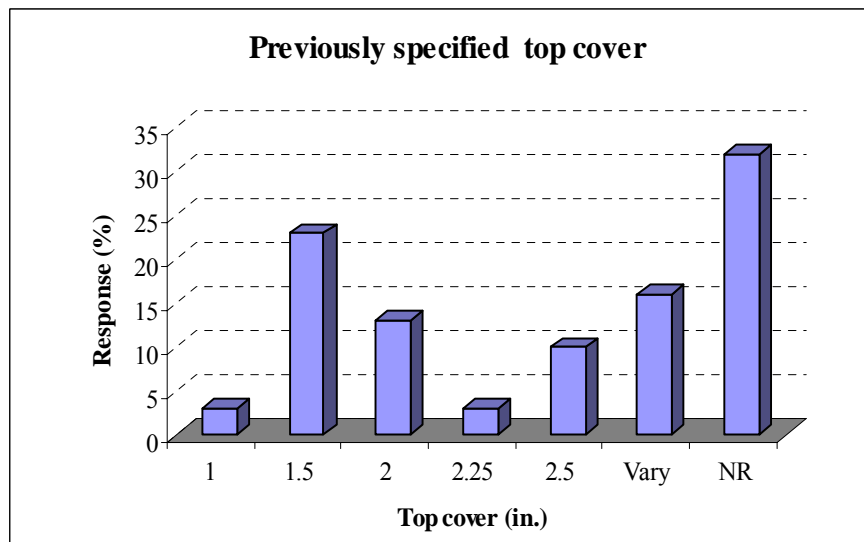


Figure 3-13. Frequency of using different top cover for bridge decks

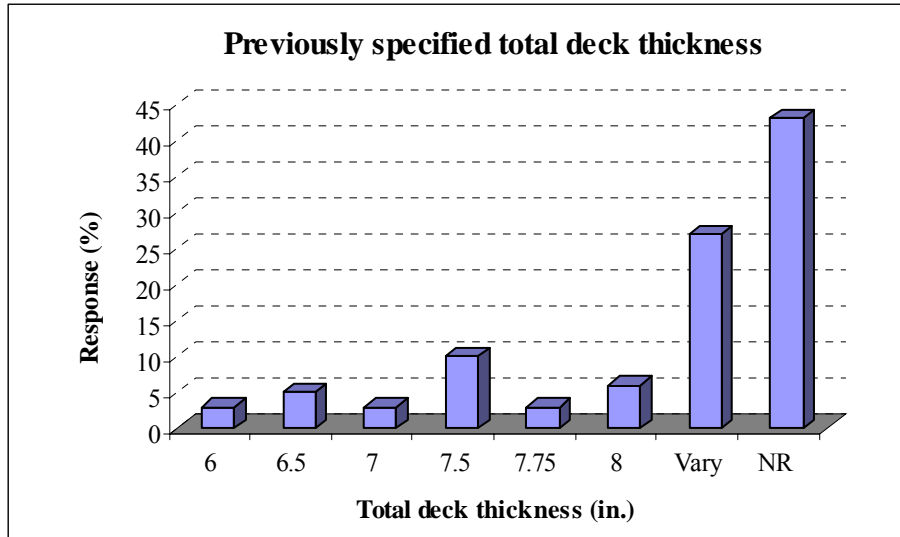


Figure 3-14. Frequency of using different deck thickness in the past

Epoxy coated reinforcements are the most commonly used among the responding states. Percentages of usage of different types of reinforcement such as epoxy coated, black, galvanized, and stainless steel among the states are presented in the Figure 3-15.

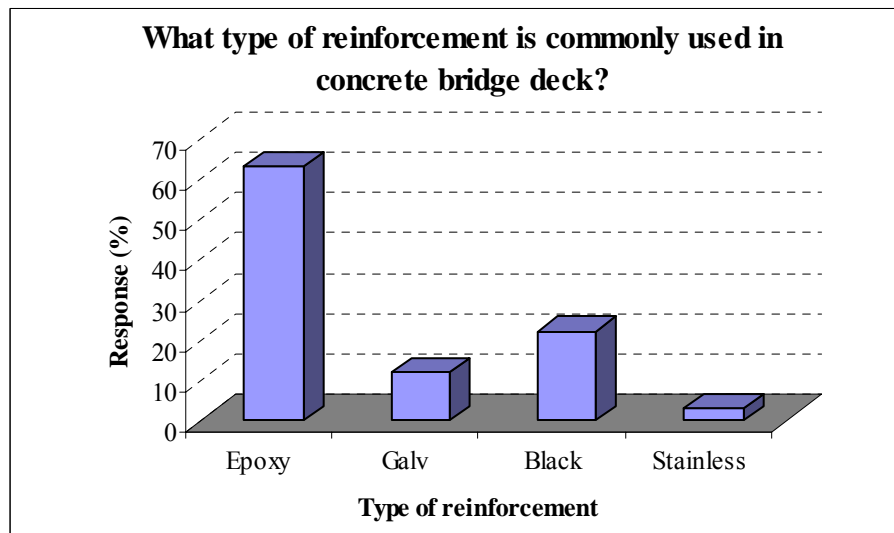
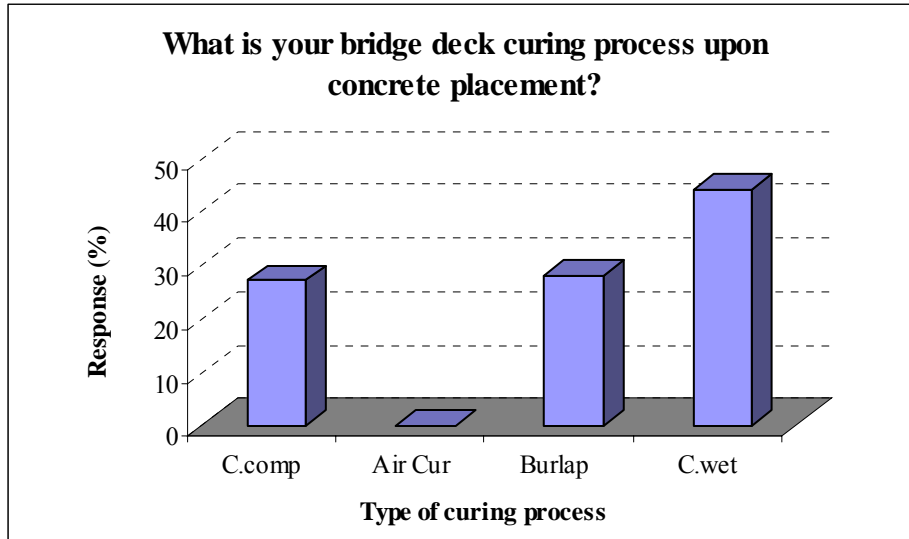
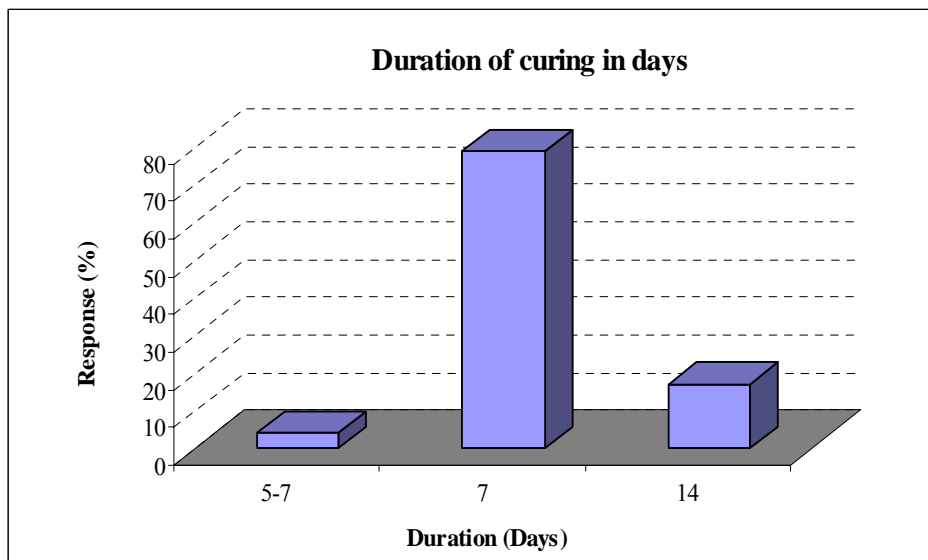


Figure 3-15. Frequency of using different reinforcement types on bridge decks

The most commonly used curing procedure is continuous wet curing. Other methods used are curing by burlap cover, air curing, and curing compound (Figure 3-16). The recommended duration for wet curing is seven days (Figure 3-17).



**Figure 3-16. Frequency of using different curing methods upon concrete placement**



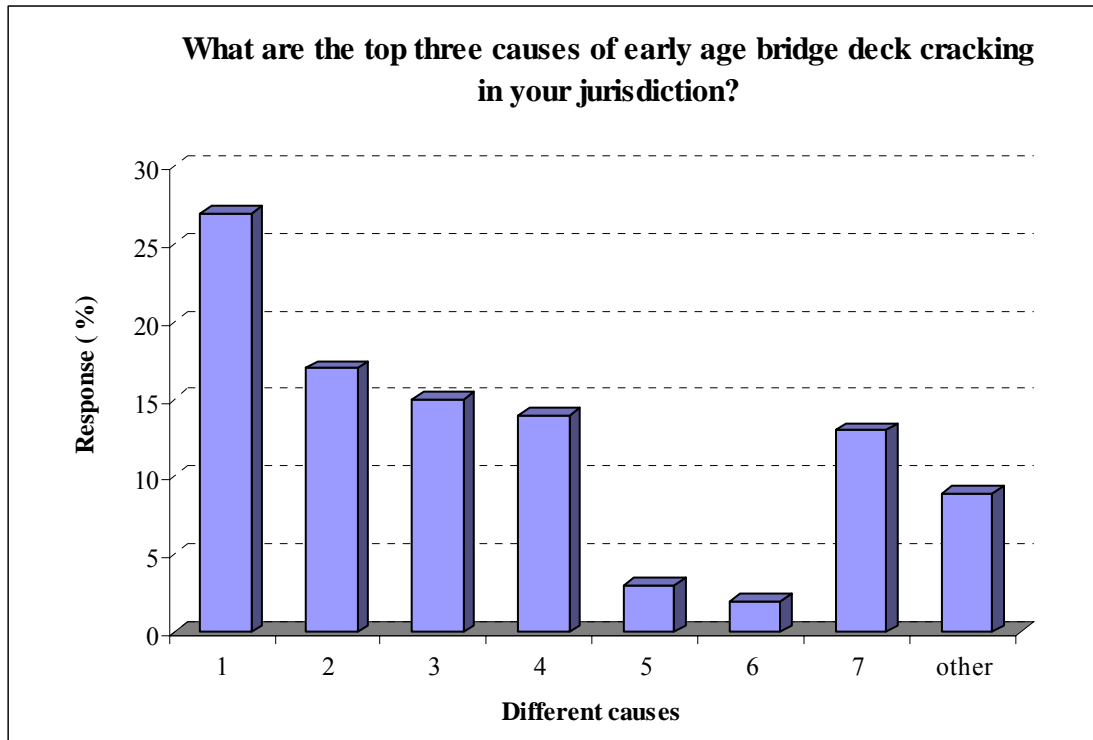
**Figure 3-17. Frequency of using different curing durations**

The causes of early-age bridge deck cracking identified by the respondents are:

1. Substandard curing
2. Construction practice
3. Mix design
4. Thermal stresses
5. Structure type
6. Epoxy reinforcements
7. Restraints

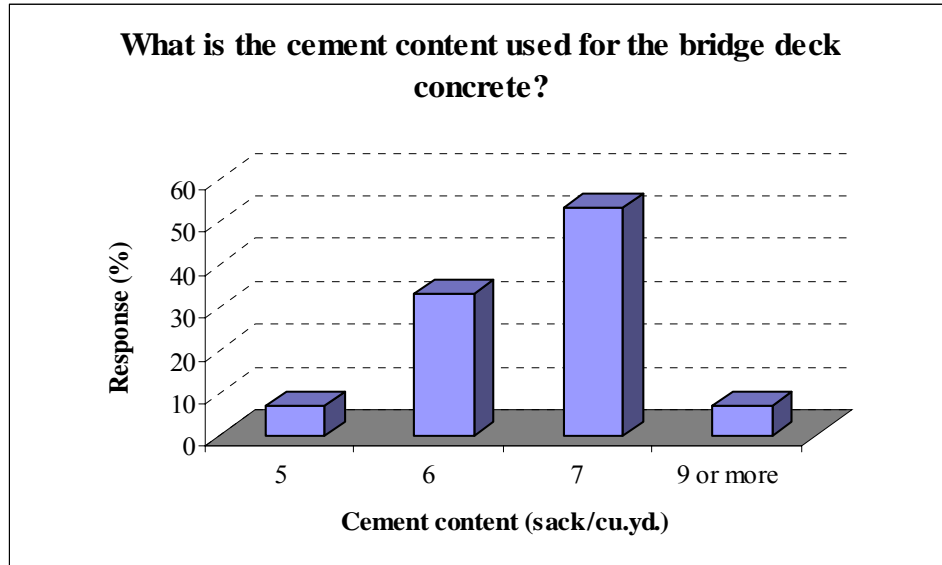


The percentage of responses for the causes of bridge deck cracking has been calculated based on the frequency of responses. In the survey questionnaire (Question 7), respondents were asked to identify the top three causes of early-age bridge deck cracking only, and not to categorize the causes according to their occurrence.



**Figure 3-18. Frequency of top three causes of early-age bridge deck cracking**

According to the compiled survey data, 52 percent of the responding states use a cement content of 7 sacks/yd<sup>3</sup> and 32 percent use 6 sacks/yd<sup>3</sup> (Figure 3-19).

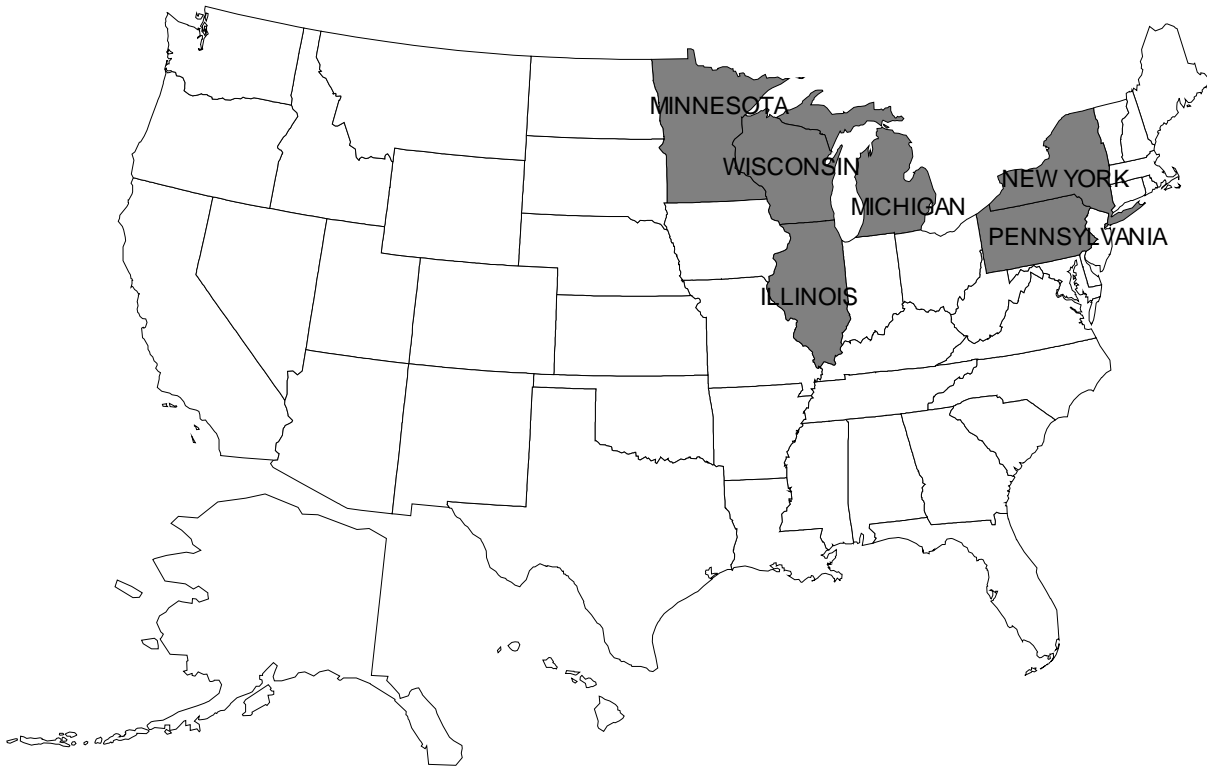


**Figure 3-19. Frequency of using different amounts of cement in concrete mix**

### 3.3 CONCLUSION

An extensive amount of information has been extracted regarding the early-age cracking problem of concrete bridge decks, materials, construction practices, and measures taken to minimize early-age cracking of concrete decks.

All the responding states (except Hawaii) acknowledged that they have experienced early-age deck cracking. Sixty-six percent of the responding states including Michigan observed cracking within the first few months of construction. The most prevalent type of cracking observed on decks is transverse cracks, which is similar to Michigan's observation. Sixty-eight percent responded that the average deck service life meets their expectations, unlike the state of Michigan. Most of the responding State DOTs including Michigan emphasized changing the mix design and increasing the reinforcement cover in order to improve the durability of decks. Forty-five and twenty-nine percent of responded states have been using fly ash and ground granulated blast-furnace slag, respectively in their mix design. In Michigan deck overlay mixes include mineral additives. The most popular type of admixture is air entrainment, which is similar to Michigan practices. Fifty-eight percent of the responding states have been using a top cover of 2.5-inch, but MDOT utilizes a 3-inch top cover. The most often used (45%) dimension for deck thickness is 8-inch, and MDOT has been using 9-inch decks. The most prevalent type of reinforcement is epoxy coated, 62% of responding states including Michigan uses this type. Continuous wet curing is the most popular method of curing specified by responding DOTs. The State of Michigan's curing practices are to use curing compounds and continuous wet curing for 7 days. The most predominant causes of early-age deck cracking are substandard curing, construction practices, and mix design analogous to State of Michigan. Fifty two percent of the responding states including Michigan have been using 7sacks/yd<sup>3</sup> of cement in concrete mix design for decks.



**Figure 3-20. States with similar climatic exposures to Michigan**

The information extracted from the nationwide survey was also compared specifically to the States of the Central North East Region (Illinois, Minnesota, New York, Pennsylvania, and Wisconsin) because they have similar weather exposure to Michigan. These states identified that they have experienced early-age cracking on concrete bridge decks during the first few months of service, and the prevalent type of cracking is transverse cracking. According to the responses, Illinois and Minnesota replied that their bridge deck service life meets their expectation, which is more than 35 years. But in case of Michigan, New York, Pennsylvania, and Wisconsin, the bridge deck service life is less than 35 years, which does not satisfy the expectations. The most popularly taken measures among these states in order to improve the durability of decks are increased reinforcement cover, changed material, changed mix design, and altered curing procedure. Illinois, New York, and Pennsylvania have been using fly ash (FA), silica fume (SF), and ground granulated blast-furnace slag (GGBS) as mineral additives in their mix design. Michigan has been using FA and SF and Wisconsin has been using FA and GGBS. New York, Minnesota, and Wisconsin responded that the chemical admixtures used are retarder (R), air-entrainment (AE), and mid range water reducer (MRWR), where as Illinois, Michigan, and

Pennsylvania are using only AE admixture. The most often-used deck thickness among the states is 8 inches, but Michigan and Minnesota's practice is to use 9-inch deck. Among these five states, epoxy coated reinforcements are very common, which is similar to Michigan. The State of New York has also been using black and galvanized reinforcement along with epoxy coated. The common curing practice among these states is continuous wet curing with the exception of Illinois. The top three causes of cracking identified by the respondents are substandard curing, construction practice, and mix design, which cause volume change of concrete due to thermal and shrinkage effects. The identified top three causes of cracking are also parallel to Michigan.

## **4 FIELD INSPECTION AND DATA ANALYSES**

This chapter presents the inspection data for 20 bridges that were built between 1997 and 2001. Section 4.1 presents the list of bridges and the data collection procedure. Data includes crack orientation, length, and width. In addition, Section 4.2 presents the method for processing the collected inspection data that will be used in Section 4.3. Section 4.3 includes analysis of the effect of bridge geometry, and parameters related to design on early-age bridge deck cracking including skew, span type, year built, ADTT, girder type, and inspected lane-span length. Finally, Section 4.4 presents the conclusions made on analysis results.

### **4.1 FIELD INSPECTION**

Twenty existing bridges were randomly selected throughout the state to be included in this task of inspection. In all cases, the deck was at most of five years of age. The purpose was to document the extent of early-age deck cracking. This list was then approved by MDOT and is shown in Table 4-1. All 20 bridges have been inspected.

A sample inspection data sheet is included due to the volume of raw data sheets. Compiled inspection raw data for all the bridges is given in Appendix B. The inspection data obtained for Bridge (S04-82062) in the Metro region is shown in Figure 4-1. Cracks are marked on the sheet as lines. The length and the width are noted along the crack line. Pictures taken of the deck are marked on the inspection sheet. The picture number is given within brackets with an arrow showing the direction from which the picture was taken. Some selected pictures of the inspected bridge deck are shown in Figure 4-2. The bridge carries Scotten over US-12. This deck was placed in 2000, thus is 3 years old. The inspection data shows that there is significant cracking.

**Table 4-1. List of Bridge Decks Inspected**

Bridge ID	Year Built	Facility Carried	Features Intersected	ADT
S19 of 82023	1997	14th St.	I-94	9172
S11 of 82025	1997	Harper Av.	I-94	9250
S01 of 82111	1997	Monroe Av.	I-375	1000
S09 of 82252	1997	State Fair Av.	I-75	10960
B01 of 06071	1998	M-13	Saganning Creek	6400
B02 of 06071	1998	M-13	S BR Pine River	6400
S27 of 41064	1998	M-6 EB	M-37	16500
S28 of 41064	1998	M-6 WB	M-37	14900
S06 of 82025	1999	Barrett	I-94	1500
S03 of 63022	1999	South Hill Rd	I-96	700
S15 of 25032	1999	M-57	I-75	45000
B01 of 44012	1999	M-24	S BR Flint River	16020
B03 of 73031	2000	M-52	N BR Bad River	14000
S17 of 82112	2000	Oakman	M-10	15170
S04 of 82062	2000	Scotten	US-12	13000
S03 of 82024	2000	Woodward	I-94	16000
S03 of 82192	2001	Fern	M-39	7500
S06 of 82192	2001	Village	M-39	4500
B02 of 64012	2001	US-31 BR	N.BR. Pentwater R.	2278
B03 of 64012	2001	US-31 BR	Bass Lake Creek	3500

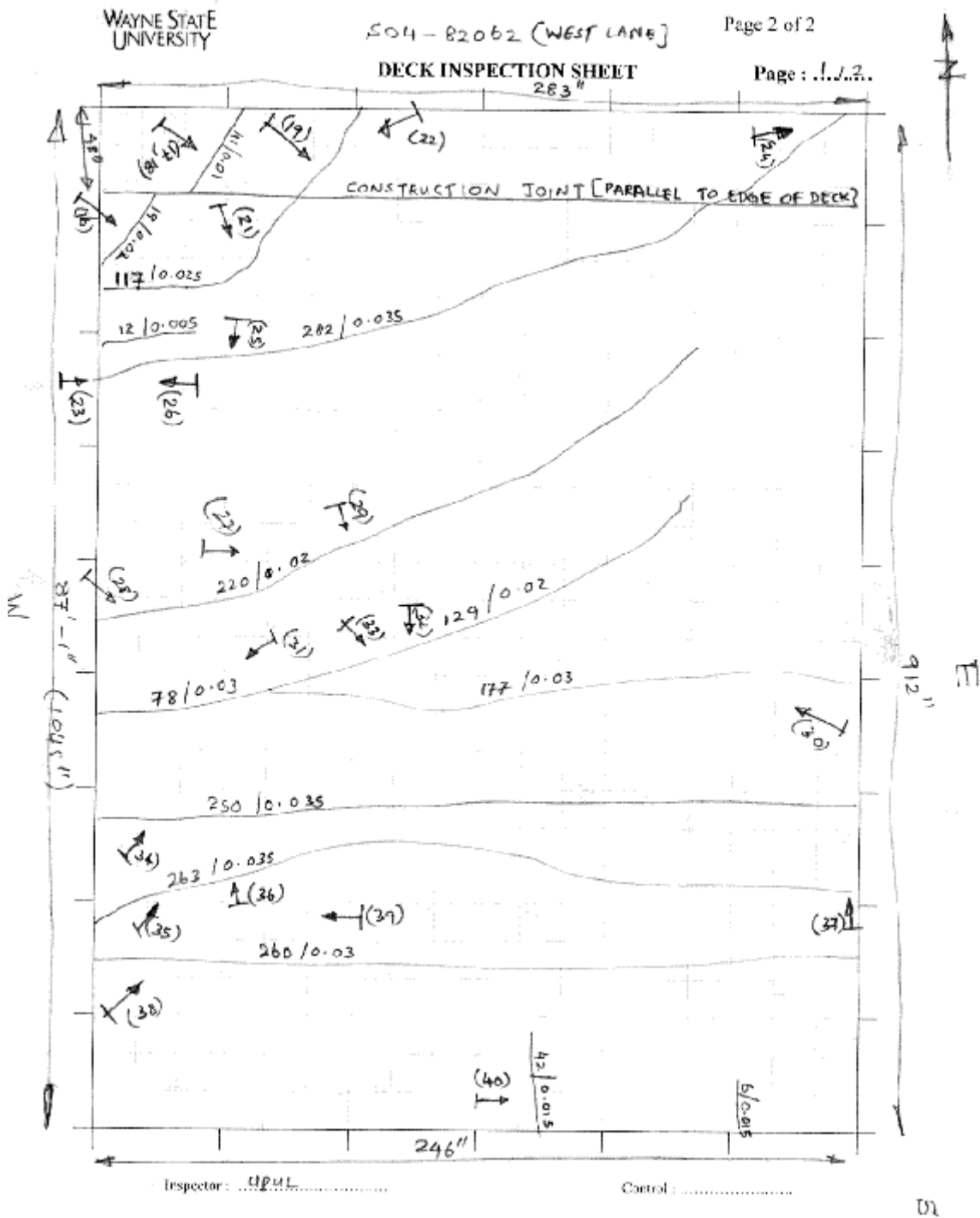
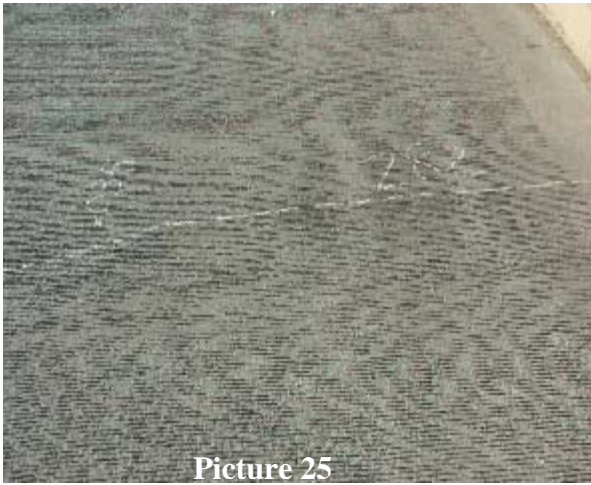
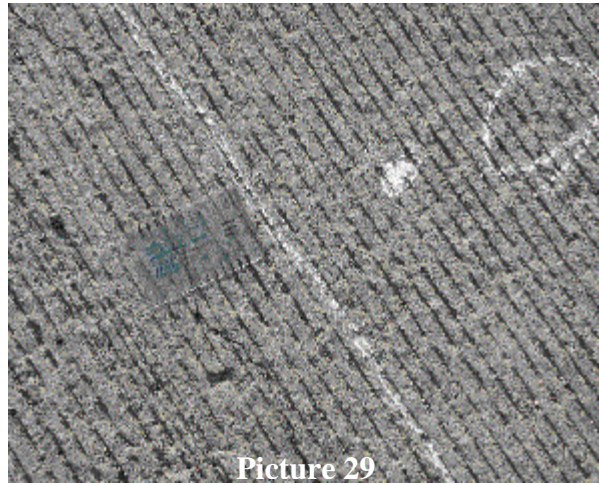


Figure 4-1. Deck inspection template example with sample inspection data

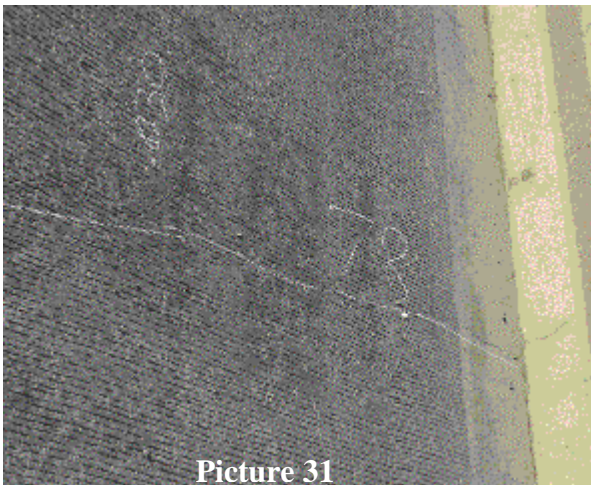




Picture 25



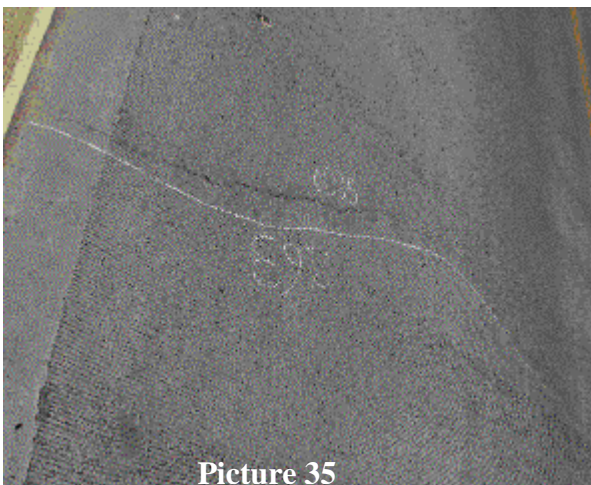
Picture 29



Picture 31



Picture 34



Picture 35



Picture 36

**Figure 4-2. Selected photos taken during the deck inspection**

## 4.2 INSPECTION DATA PROCESSING STEPS

From the inspection data sheet, the crack orientation can be categorized into four groups.

1. Longitudinal cracks: cracks that are predominantly parallel to the traffic direction.
2. Transverse cracks: cracks that are predominantly perpendicular to the traffic direction.
3. Diagonal cracks: cracks that are not transverse or longitudinal cracks.
4. Map cracking: a series of cracks that extend only into the upper surface of the deck.

The crack density of groups 1, 2, and 3 was calculated by dividing the sum of the lengths of the cracks for each group by the area of the inspected bridge lane-span. The crack density of group 4, map cracking, was calculated by dividing the sum of cracked area by the area of the inspected bridge lane-span. Table 4-2 summarizes the crack density of each crack group for the 20 inspected bridges and the following controlling parameters: bridge skew, span type, year built, girder type, the inspected lane-span length, and slab thickness.

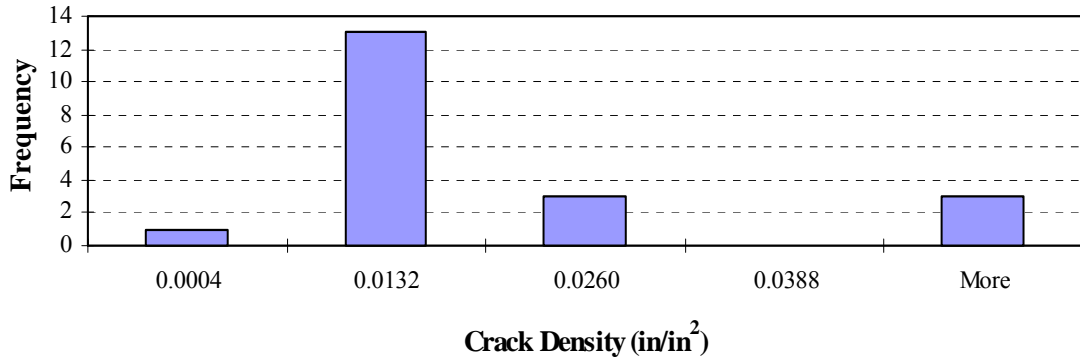
In order to study the relationship between the crack density and the controlling factors mentioned above, the crack density histogram of groups 1, 2, and 3 is calculated first. Figure 4-3, Figure 4-4, and Figure 4-5 show the crack density histogram for longitudinal, transverse, and diagonal cracks respectively. The map crack density for 14 out of the 20 bridge decks is equal to zero.

In order to have a continuous longitudinal crack density histogram, the last 3 extreme values in Figure 4-3 (3 bridges) are deleted as shown in Figure 4-6. For the transverse deck cracking histogram to be continuous, just one bridge is excluded from the analysis as shown in Figure 4-7. The analysis will consider all the diagonal crack density data, since the histogram is continuous.

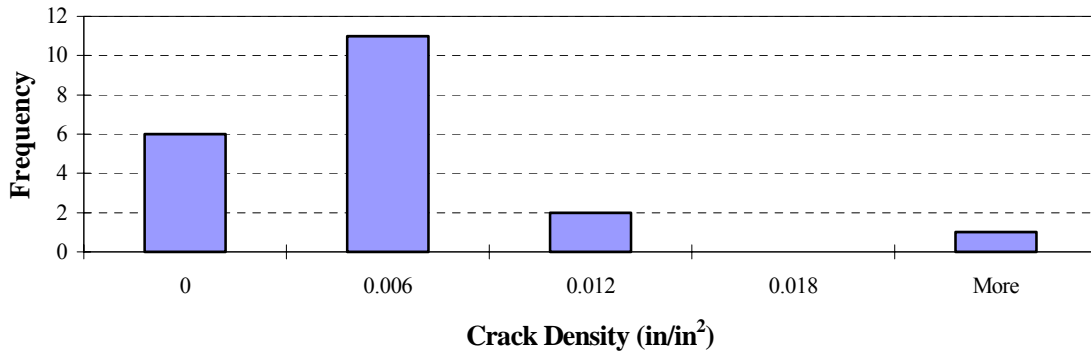
**Table 4-2. Deck Crack Density of the Inspected Bridges and Controlling Parameters**

Bridge ID	Longitudinal crack density (in/in <sup>2</sup> )	Transverse crack density (in/in <sup>2</sup> )	Diagonal crack density (in/in <sup>2</sup> )	Map crack density (in <sup>2</sup> /in <sup>2</sup> )	Span length (ft)	Span type	Girder type	Slab thickness (in)	Year built	Skew angle (deg)
<b>S01 of 82111</b>	1.37E-02	4.84E-03	1.86E-03	0	27.43	Simple	Spread Box	8.5	1997	5
<b>S09 of 82252</b>	2.51E-02	2.68E-03	2.79E-03	0.11251	24.75	Continuous	Steel	9	1997	0
<b>S11 of 82025</b>	1.70E-02	0.00E+00	7.98E-03	0.002199	39	Simple	Steel	8	1997	50
<b>S19 of 82023</b>	5.00E-02	4.90E-04	2.79E-04	0.059583	28.08	Simple	Steel	8	1997	0
<b>B01 of 06071</b>	1.06E-02	0.00E+00	0.00E+00	0	25	Continuous*	Adj Box	6	1998	0
<b>B02 of 06071</b>	1.13E-02	1.19E-03	0.00E+00	0	32	Continuous	Steel	8	1998	0
<b>S27 of 41064</b>	4.13E-04	0.00E+00	0.00E+00	0	131.56	Simple	PCI	9	1998	19
<b>S28 of 41064</b>	1.88E-03	4.91E-04	6.84E-04	0	131.56	Simple	PCI	9	1998	19
<b>B01 of 44012</b>	6.19E-03	4.92E-03	5.88E-04	0	64.99	Simple	Steel	9	1999	0
<b>S03 of 63022</b>	7.99E-03	3.12E-04	0.00E+00	0	112.5	Simple	Adj Box	6	1999	24
<b>S06 of 82025</b>	5.23E-03	0.00E+00	8.73E-04	0.000245	30.92	Simple	Steel	9	1999	13
<b>S15 of 25032</b>	5.03E-02	2.35E-02	1.43E-02	0	32.81	Simple	Adj Box	6	1999	0
<b>B03 of 73031</b>	3.31E-03	6.66E-03	2.70E-04	0	50	Simple	PCI	8	2000	0
<b>S03 of 82024</b>	5.16E-02	4.39E-03	4.22E-03	0	63.67	Continuous*	Spread Box	9	2000	6
<b>S04 of 82062</b>	2.82E-03	4.36E-03	2.13E-03	0.000661	62.5	Continuous	Steel	8	2000	28
<b>S17 of 82112</b>	1.80E-03	6.47E-03	8.70E-04	0	73.95	Continuous	Steel	9	2000	22
<b>B02 of 64012</b>	3.44E-03	8.14E-04	0.00E+00	0	49	Simple	Spread Box	9	2001	18
<b>B03 of 64012</b>	8.22E-04	0.00E+00	0.00E+00	0	50.98	Simple	Adj Box	6	2001	0
<b>S03 of 82192</b>	6.69E-03	0.00E+00	7.27E-05	0	38	Simple	Steel	9	2001	0
<b>S06 of 82192</b>	1.66E-03	1.02E-04	0.00E+00	0.002839	29.5	Simple	Steel	9	2001	0

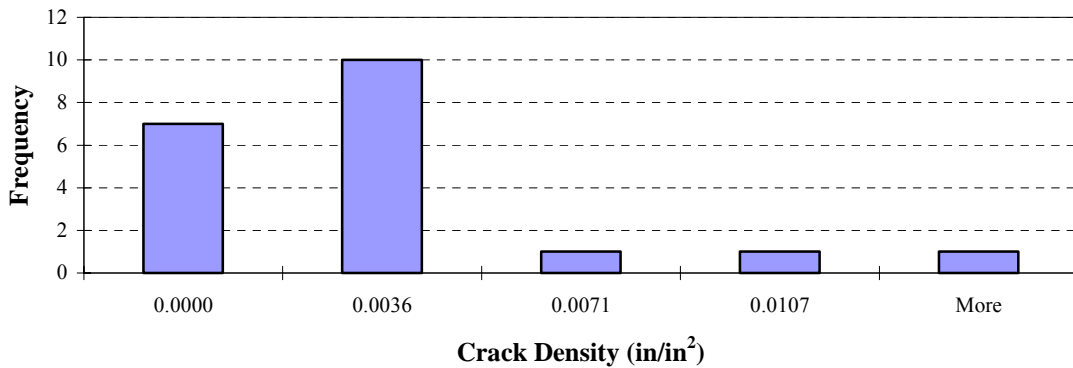
\* - Simple span with continuous deck



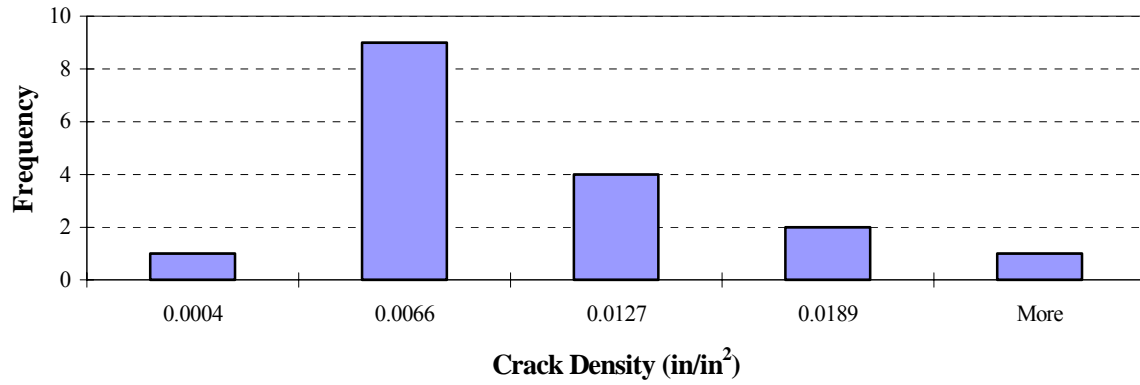
**Figure 4-3. Longitudinal crack density histogram (20 Bridges)**



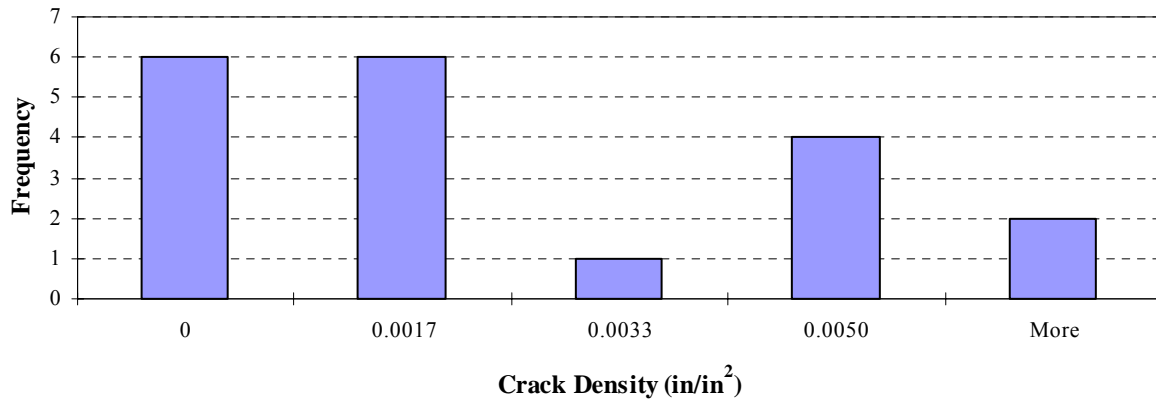
**Figure 4-4. Transverse crack density histogram (20 Bridges)**



**Figure 4-5. Diagonal crack density histogram (20 bridges)**



**Figure 4-6. Modified longitudinal crack density histogram (17 Bridges)**



**Figure 4-7. Modified transverse crack density histogram (19 Bridges)**

### 4.3 BRIDGE GEOMETRY AND DESIGN EFFECT ON DECK CRACKING

#### 4.3.1 Longitudinal Cracks and Controlling Factors

##### 4.3.1.1 Level I

At this level, only one controlling factor is considered each time in the analysis of the longitudinal crack data. Figure 4-8 through Figure 4-12 show the relationship between the crack density and each of the following parameters: bridge design type, girder type, bridge skew, slab thickness, year built, and the inspected lane-span length.

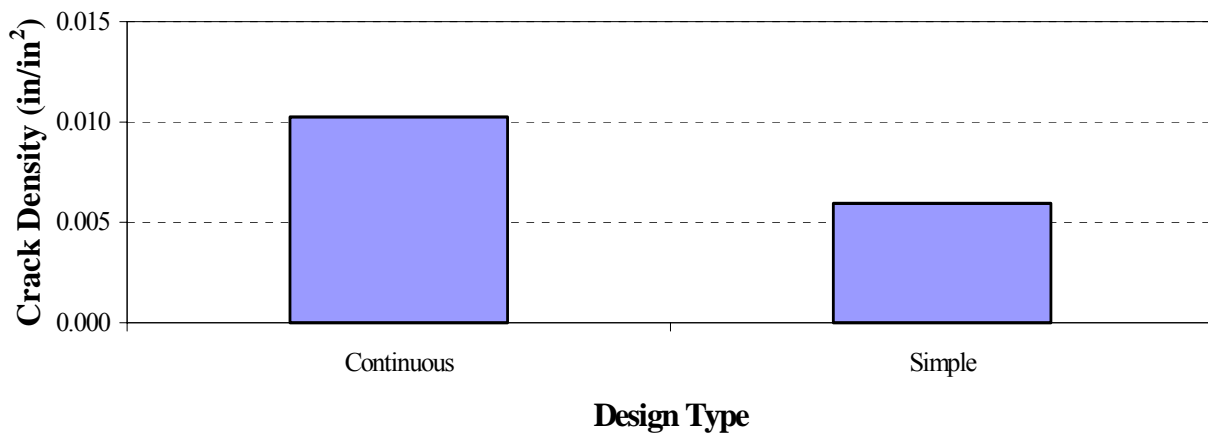


Figure 4-8. Beam structural type vs longitudinal crack density

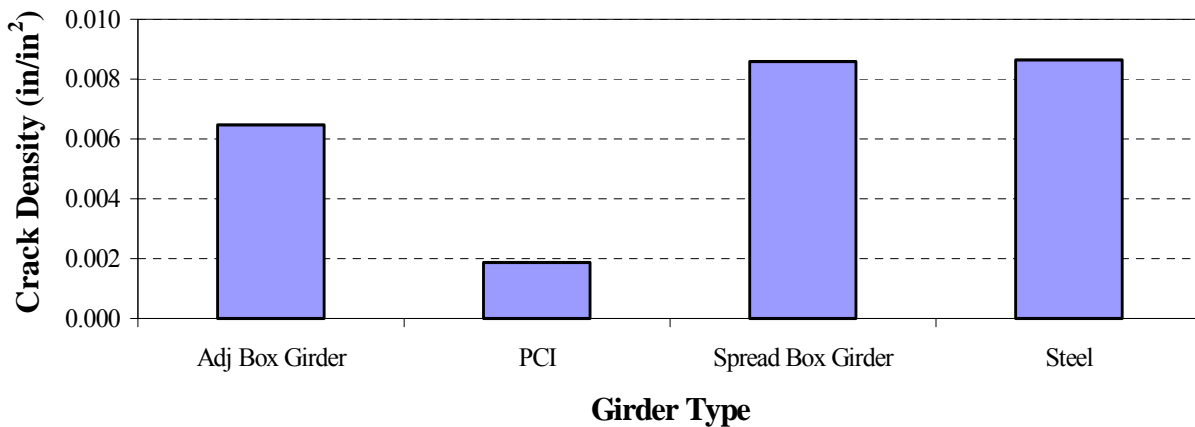
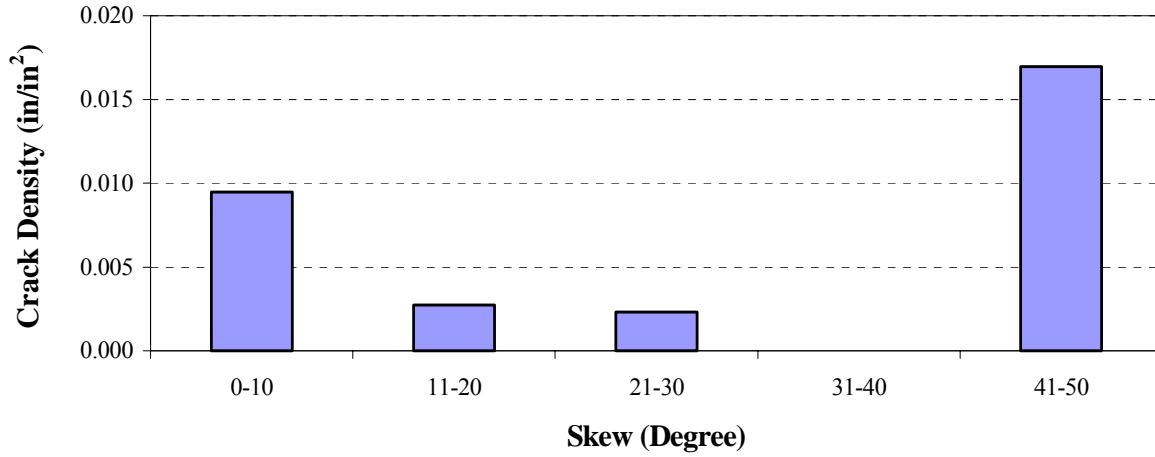
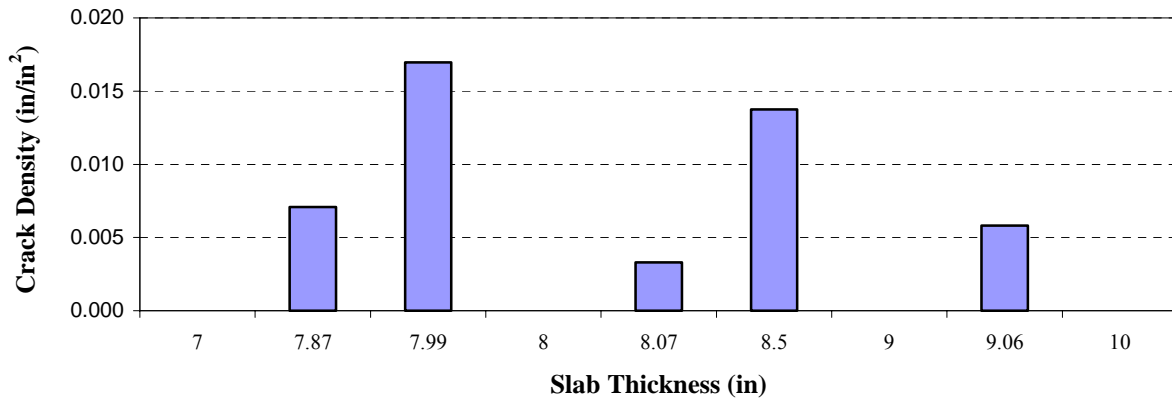


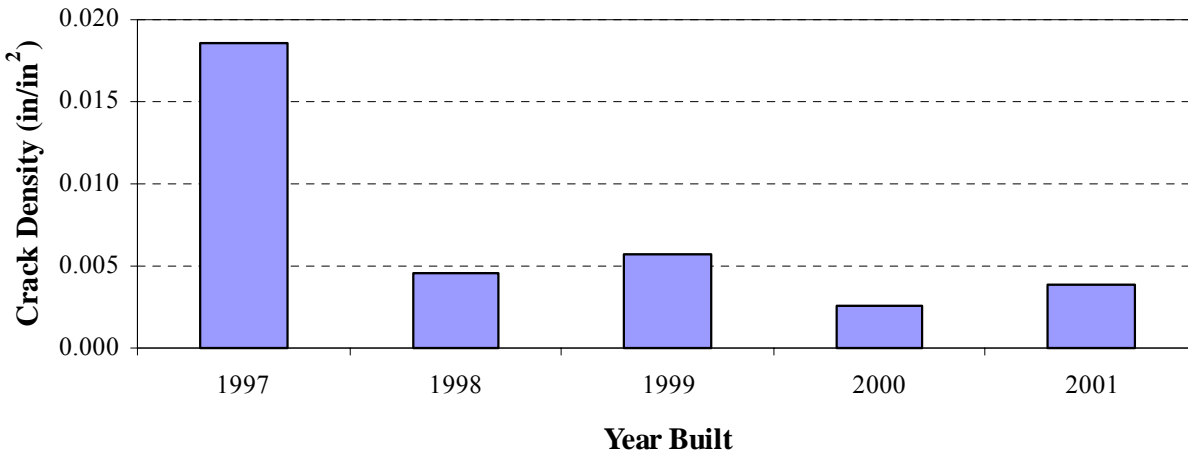
Figure 4-9. Girder type vs longitudinal crack density



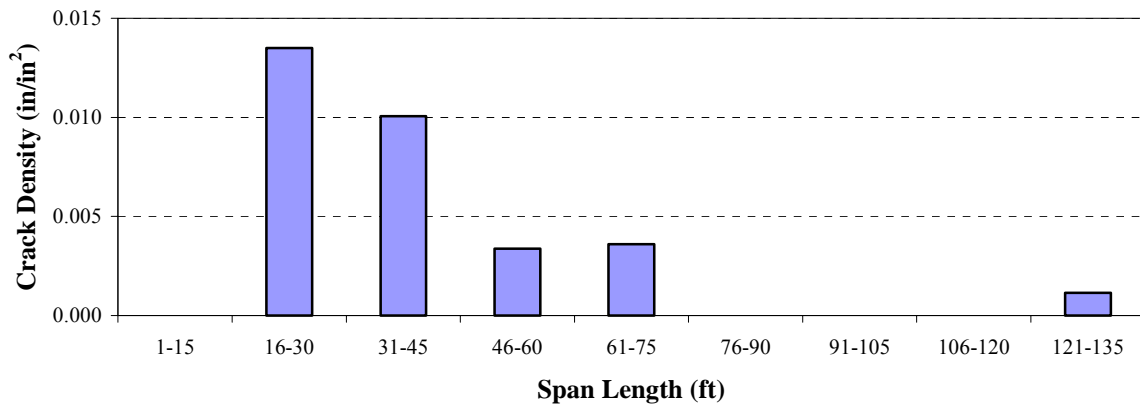
**Figure 4-10. Bridge skew vs longitudinal crack density**



**Figure 4-11. Slab thickness vs longitudinal crack density**



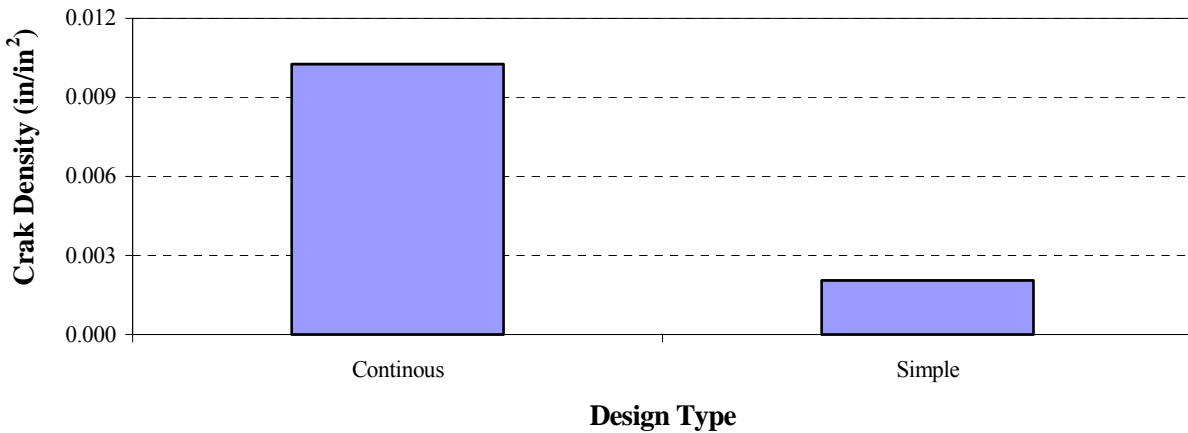
**Figure 4-12. Year built vs longitudinal crack density**



**Figure 4-13. Inspected span length vs longitudinal deck cracking**

*4.3.1.2 Level II*

At this level, two controlling factors are considered in the analysis of the longitudinal cracks. Figure 4-14 shows that multi-span continuous steel bridge decks crack more than simple span steel bridge decks. Figure 4-15 shows the relation between the longitudinal crack and the girder type for simple span bridges.



**Figure 4-14. Structural type vs longitudinal crack density in steel bridges**



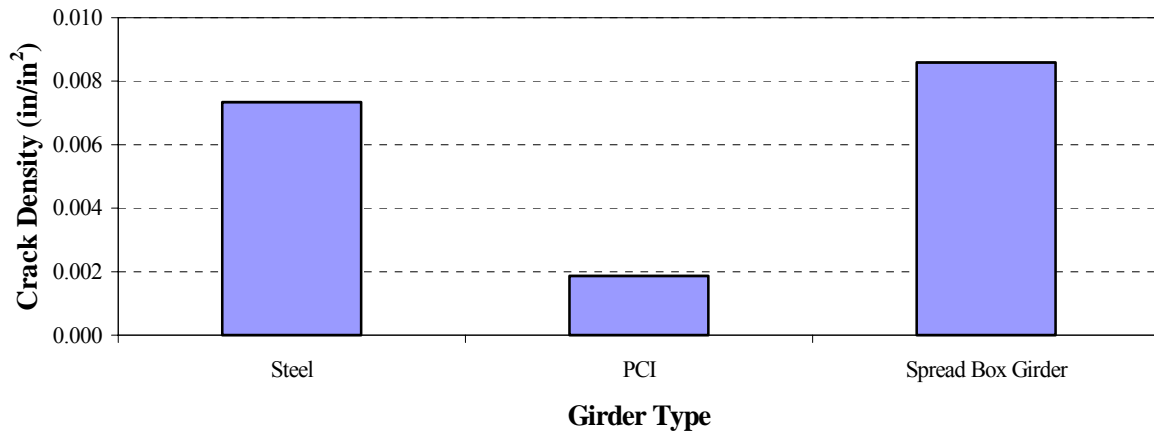


Figure 4-15. Girder type vs longitudinal crack density for simple span bridges

### 4.3.2 Transverse and Diagonal Cracks and Controlling Factors

#### 4.3.2.1 Level I

At this level, only one controlling factor is considered each time in the analysis of the transverse and diagonal crack data. Figure 4-16 through Figure 4-21 show the relationship between the crack density and each of the following parameters: bridge design type, girder type, bridge skew, slab thickness, year built, and the inspected lane-span length.

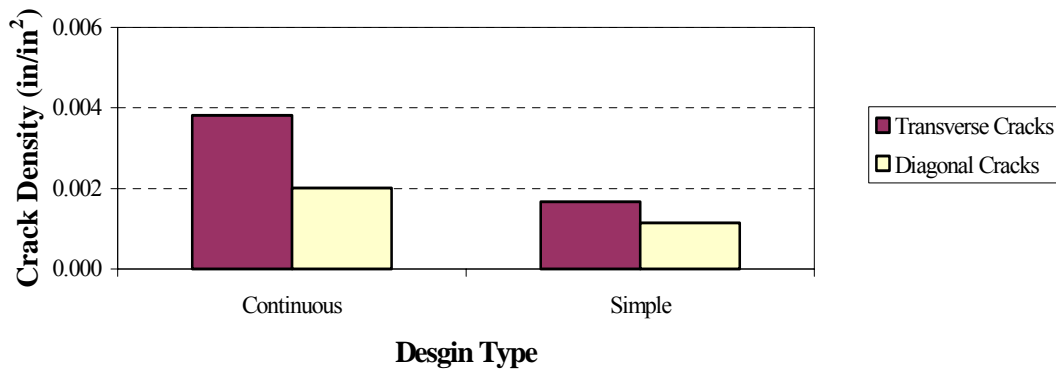


Figure 4-16. Beam structural type vs crack density

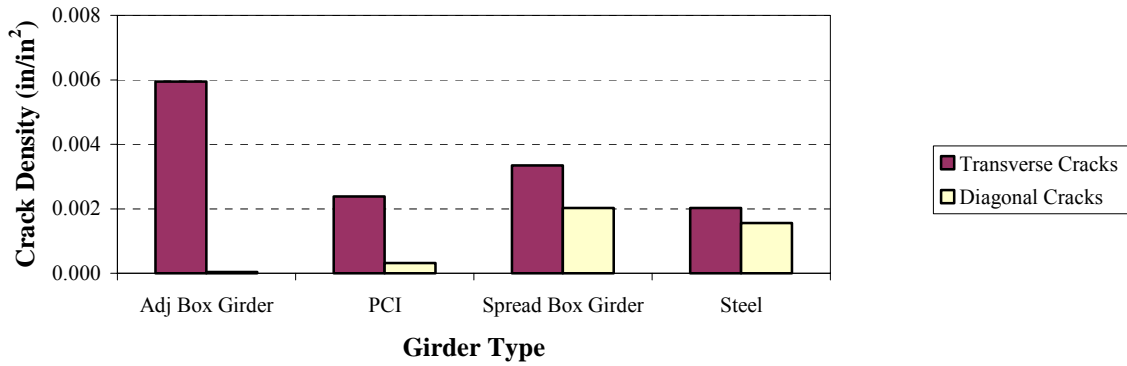


Figure 4-17. Girder type vs crack density

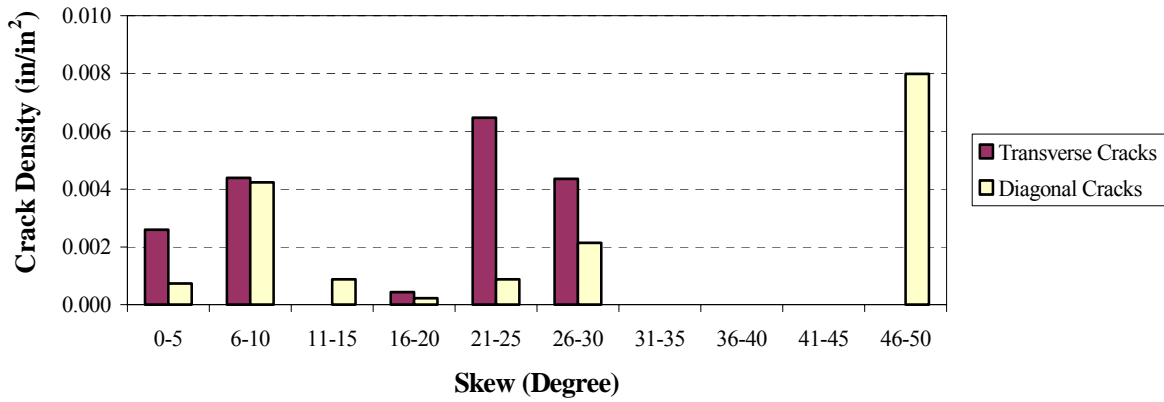


Figure 4-18. Bridge skew vs deck crack density

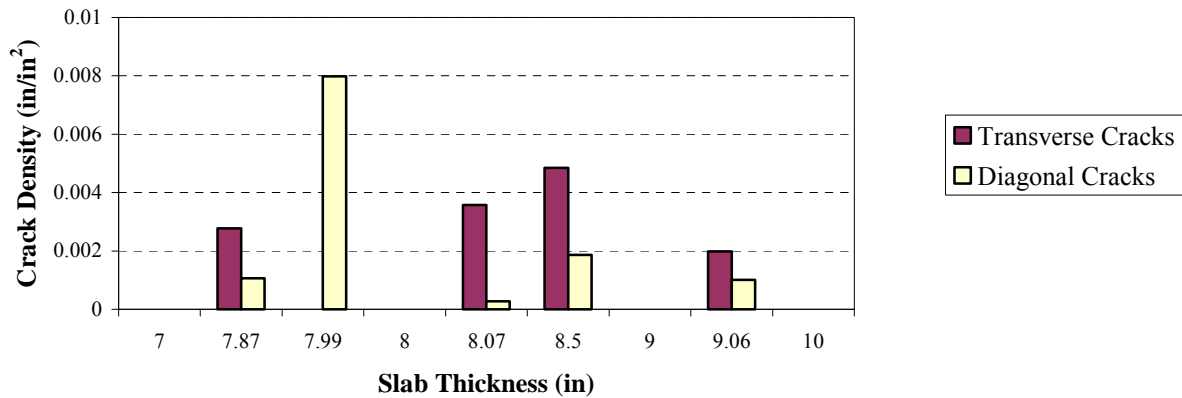


Figure 4-19. Slab thickness vs crack density

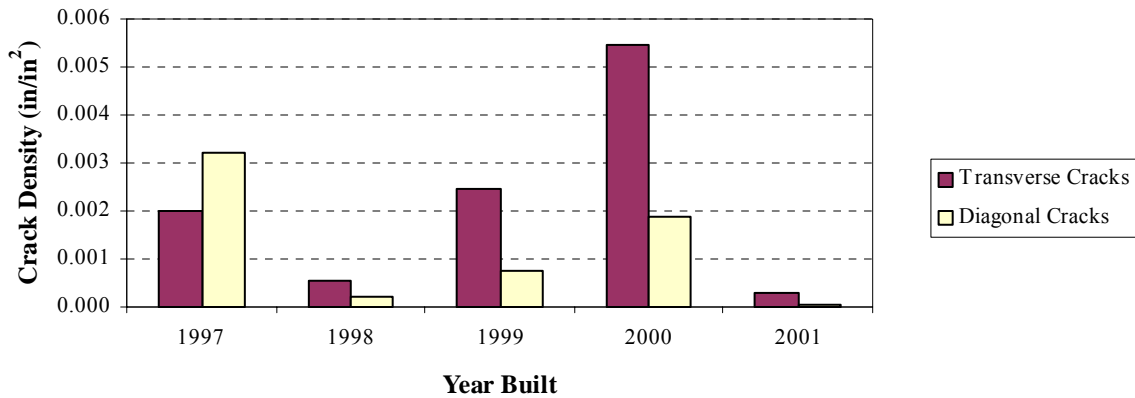


Figure 4-20. Year built vs crack density

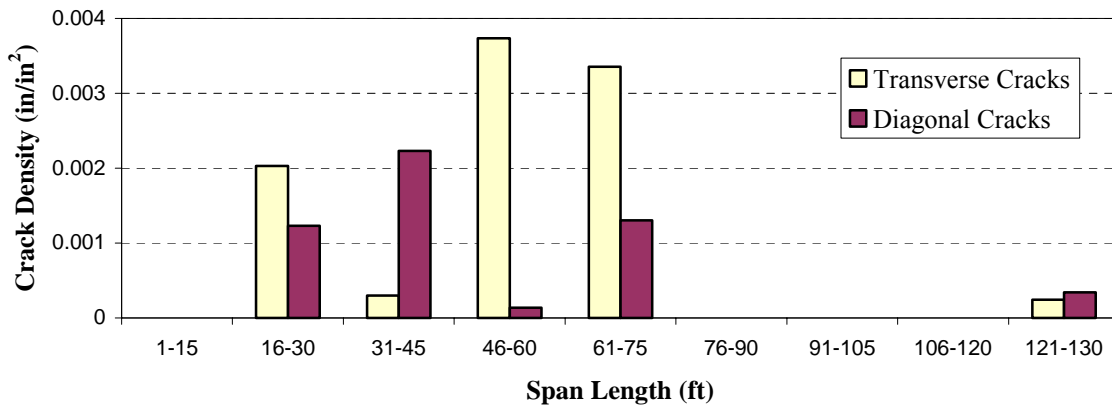


Figure 4-21. Inspected span length vs crack density

#### 4.3.2.2 Level II

At this level, two controlling factors are considered in the analysis of the transverse and diagonal cracks. Figure 4-22 shows that multi-span continuous steel bridges crack more than simple span steel bridges. Figure 4-23 and Figure 4-24 show the relationship between the longitudinal crack density and the girder type for simple span bridges and multi span continuous bridges.

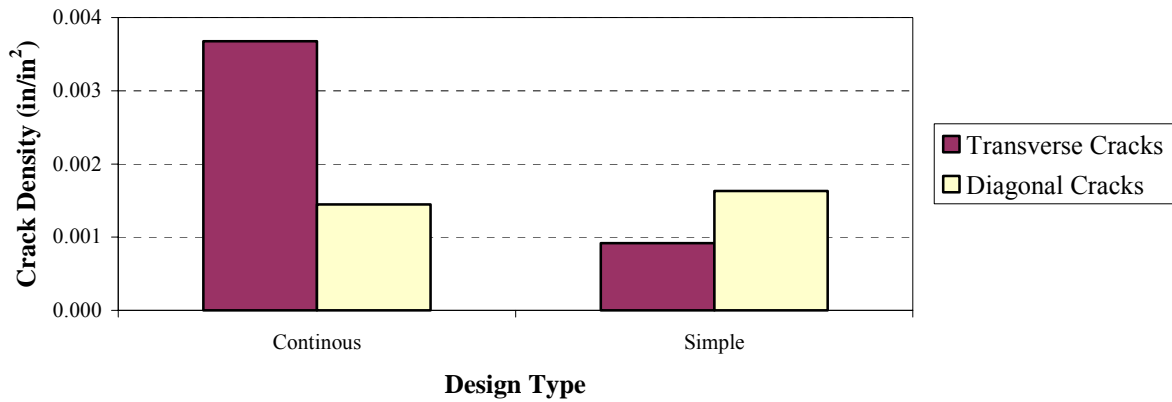


Figure 4-22. Structural type vs crack density in steel bridge

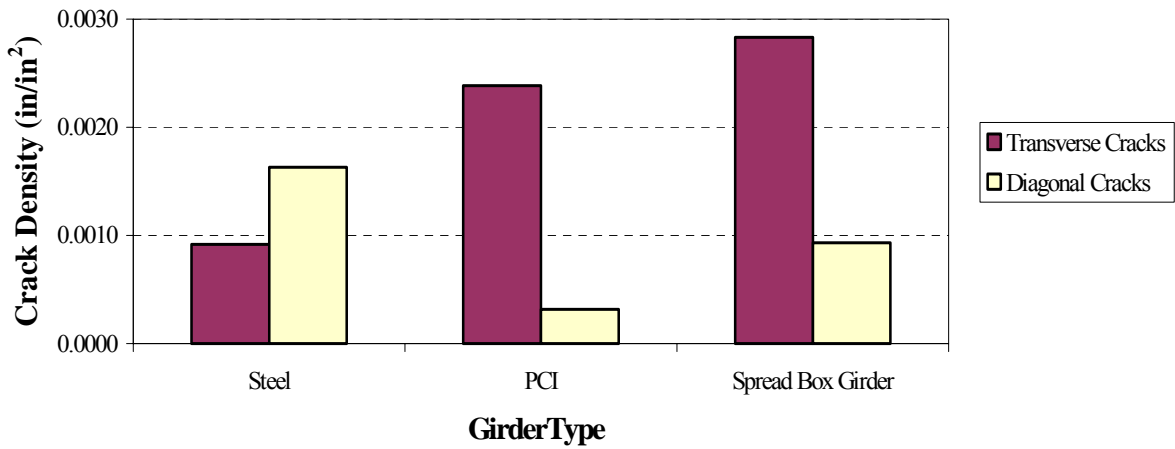


Figure 4-23. Girder type vs crack density for simple span bridges

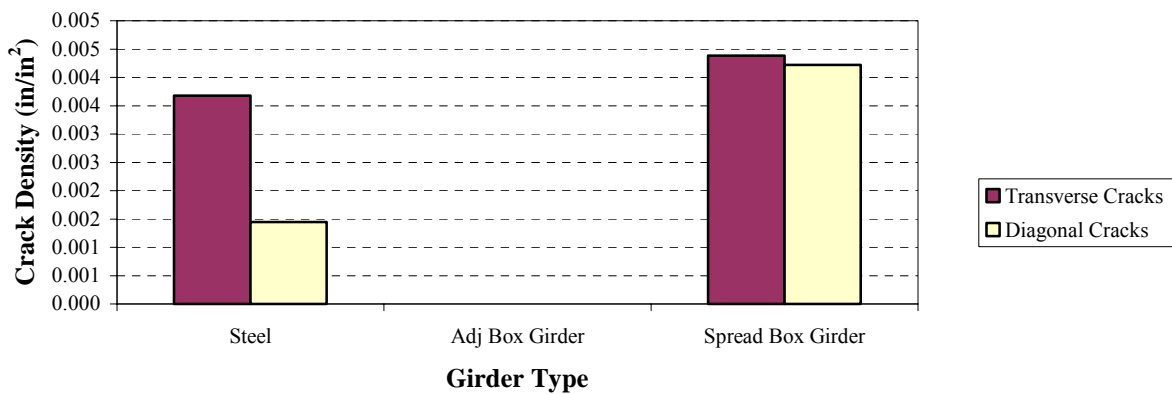


Figure 4-24. Girder type vs crack density for continuous bridges

### 4.3.3 Map Cracks and Controlling Factors

Figure 4-25 through Figure 4-30 shows the relationship between the map crack density and each of the following parameters: bridge design type, girder type, bridge skew, slab thickness, year built, and the inspected lane-span length.

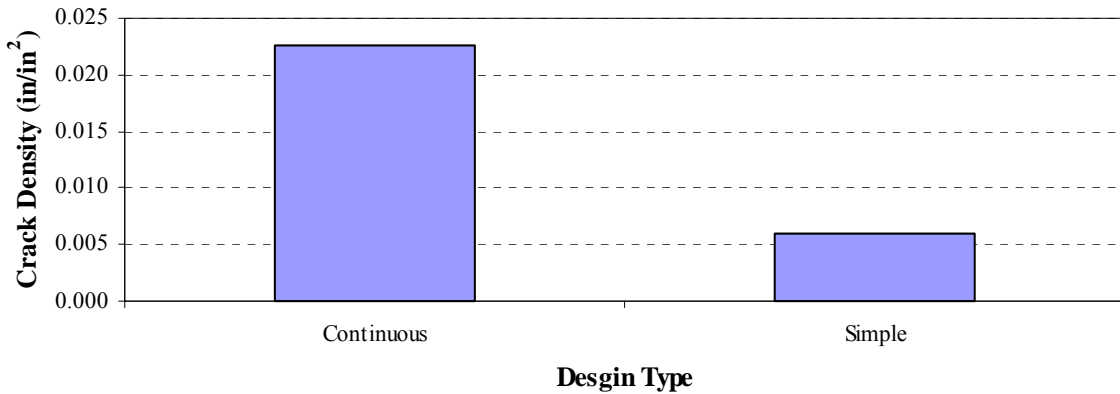


Figure 4-25. Beam structural type vs map crack density

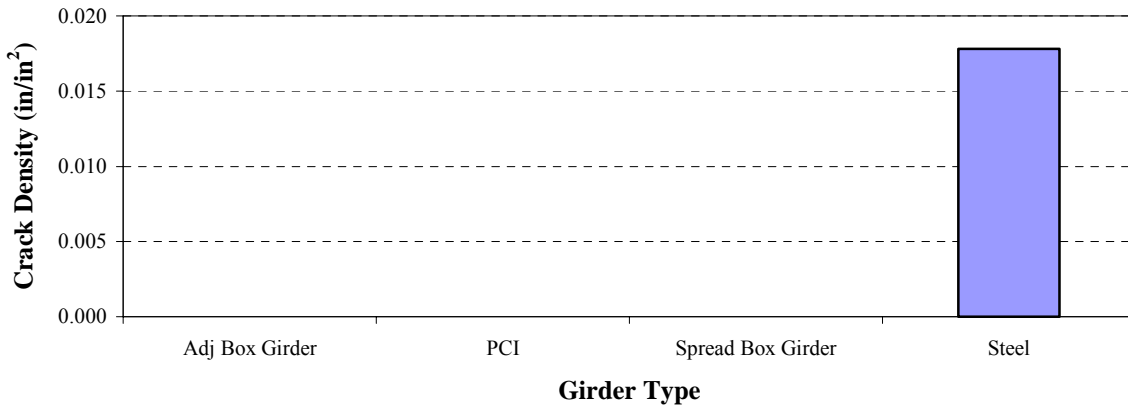


Figure 4-26. Girder type vs map crack density

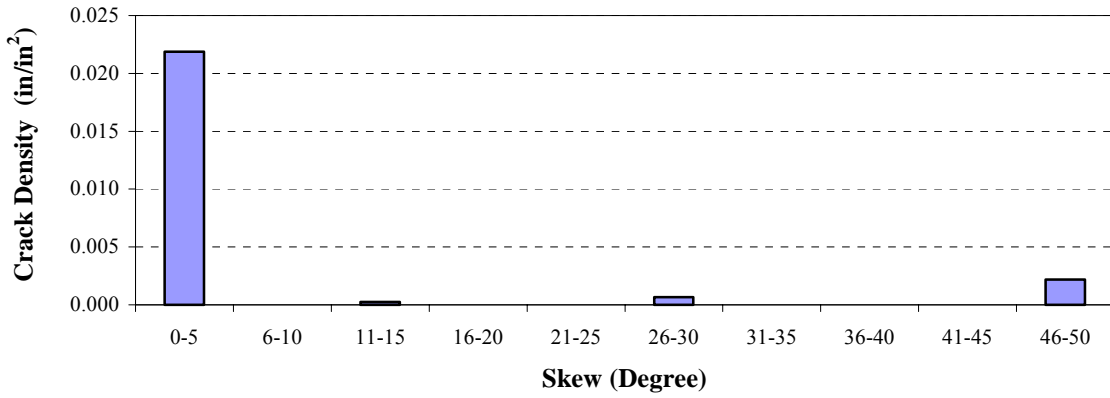


Figure 4-27. Bridge skew vs map crack density

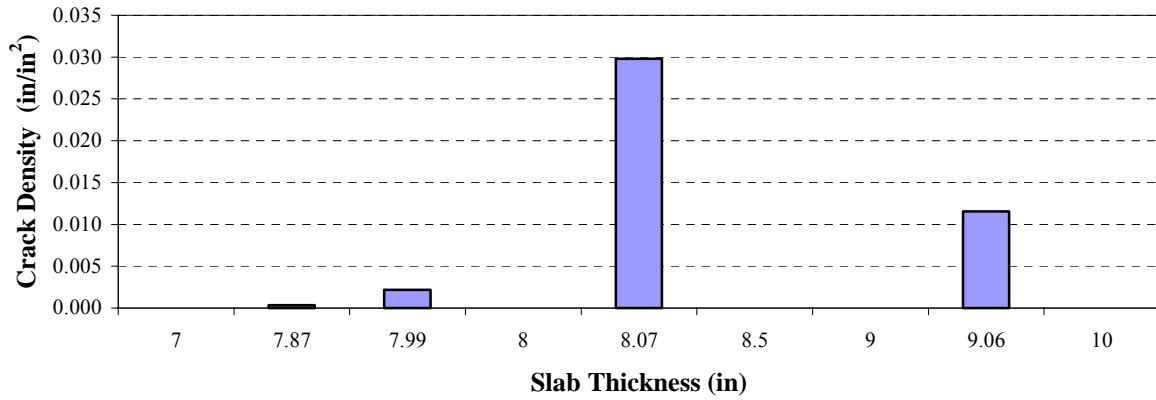


Figure 4-28. Slab thickness vs map crack density

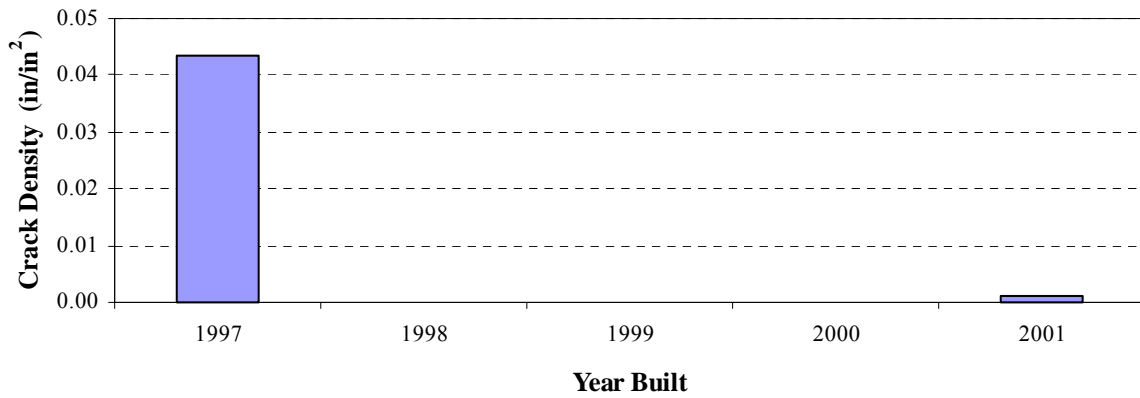


Figure 4-29. Year built vs map crack density

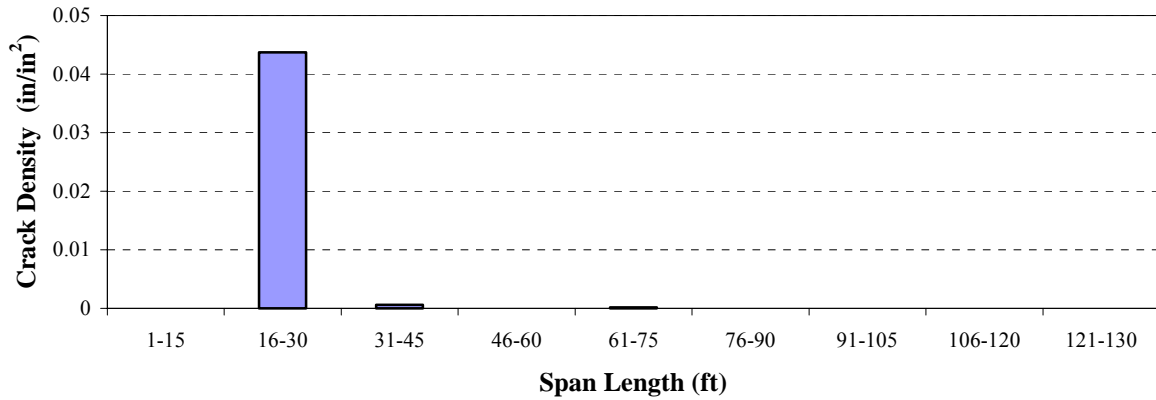


Figure 4-30. Inspected span length vs map crack density

#### 4.3.4 ADTT Effect on Bridge Deck Cracking

Table 4-3 summarizes the ADTT and the crack density for each group. The ADTT data is collected from the MDOT 2001 annual report for the bridges located on the main trunk lines. Figure 4-31 to Figure 4-33 show the relationship between each crack density type and ADTT including the adjacent box girder bridges.

Table 4-3. ADTT and Crack Density Data for the Inspected Bridges

Bridge ID	MDOT ADTT	Longitudinal Cracks	Transverse Cracks	Diagonal Cracks	Map Cracking
B01 of 06071	417	0.01061	0.00000	0.00000	0.0
B03 of 73031	385	0.00331	0.00666	0.00027	0.0
S03 of 82024	720	Extreme Value*	0.00439	0.00422	0.0
S15 of 25032	728	Extreme Value*	Extreme Value*	0.01425	0.0
B02 of 06071	789	0.01134	0.00119	0.00000	0.0
B01 of 44012	852	0.00618	0.00492	0.00059	0.0
B03 of 64012	58	0.00082	0.00000	0.00000	0.0
B02 of 64012	119	0.00343	0.00081	0.00000	0.0

\* Extreme values are determined for the histogram (Figure 4-3 and Figure 4-4) and are not included in the analysis

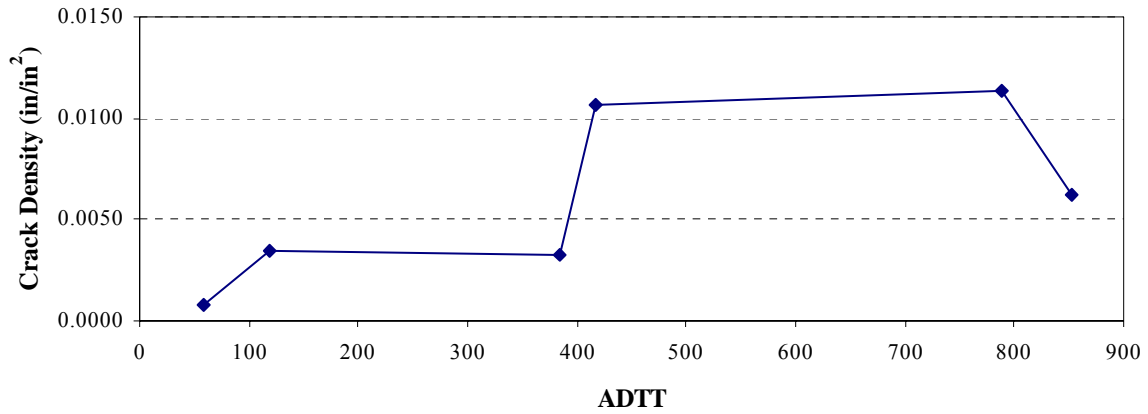


Figure 4-31. Bridge ADTT vs longitudinal crack density

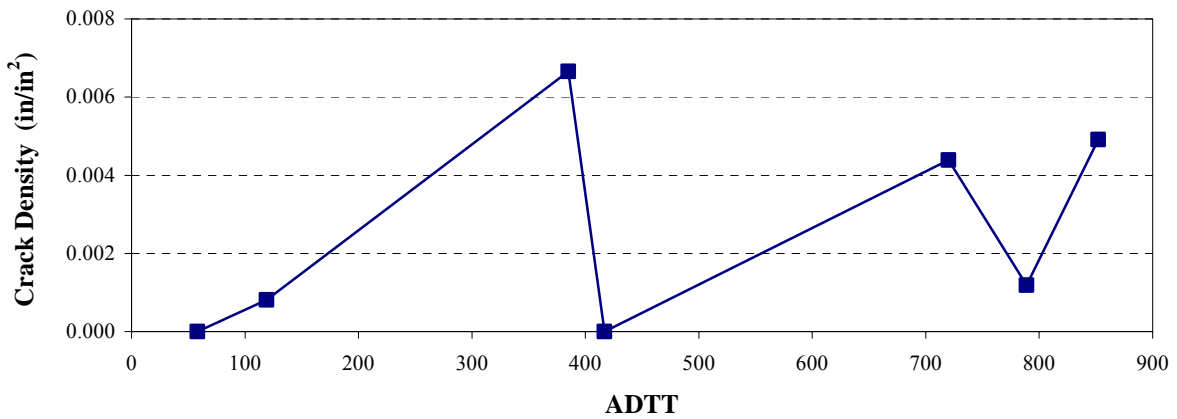


Figure 4-32. Bridge ADTT vs transverse crack density

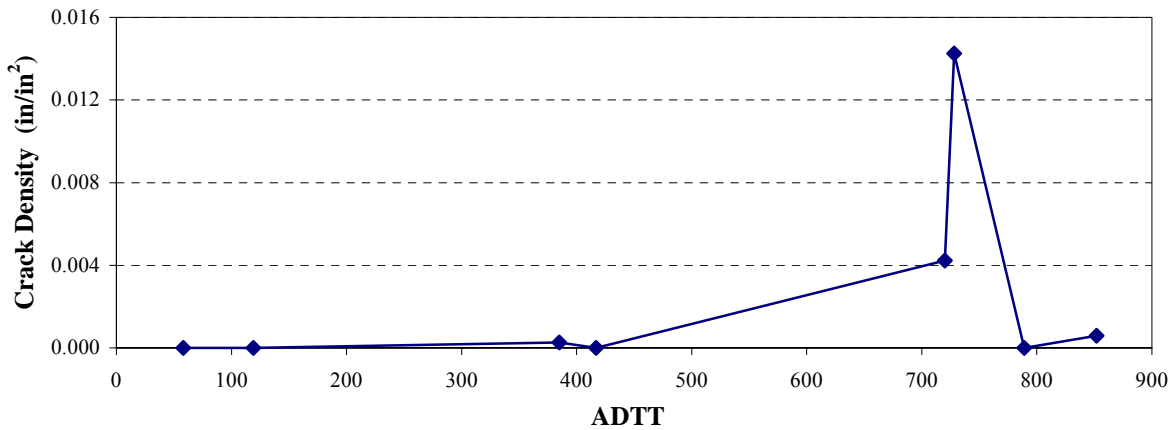


Figure 4-33. Bridge ADTT vs diagonal crack density



#### 4.4 CONCLUSIONS

From the data analysis of the field inspection of 20 bridge decks, the following conclusions are made:

1. More cracks are observed on the continuous bridges than the simple span bridges.
2. Bridges with PCI girder show minimum longitudinal crack density compared with other bridge girder types (i.e., steel, adjacent box girder, and spread box girder).
3. No clear relationship is seen between deck crack density and bridge skew, deck thickness, span length, and ADTT.
4. More transverse and diagonal cracks are observed on bridges with adjacent box girders than other girder types.
5. Map cracking is observed only on bridges with steel girders.

## 5 CONSTRUCTION MONITORING

### 5.1 OVERVIEW

Five bridge reconstruction projects involving deck replacements were selected with consideration to the construction dates. Construction monitoring of five bridges was completed including one late season deck replacement as shown in Table 5-1.

The data collected during construction monitoring of all bridges is shown in Appendix C. Ambient temperature and ambient moisture conditions were recorded during concrete placement at 10-minute intervals using digital and analog indicators. Truck number, production time (batch time/ the time truck left the plant), truck arrival time, and unloading (start/finish) time were also recorded. In some cases, according to ticket information, the time at which the truck left the plant was earlier than the batch time. Finally, starting and finishing times for concrete placement, finishing, texturing, and curing for the areas within an approximate one-yard width were monitored and recorded. Cylinder specimens (thirty - 6-in.x12-in. and twenty four – 4-in.x 8-in.) were prepared for laboratory testing. They were tested for strength, elasticity modulus, Poisson’s ratio, and permeability at different ages. Test results are given in Chapter 6.

**Table 5-1. List of Bridges Monitored during Deck Placement**

Bridge ID	Facility Carried	Features Intersected	Length (ft.)	Width (ft.)	Skew (Deg.)	Beam Type	Date
S05 of 82191	Vreeland Rd.	I-75	190	45	2	AASHTO B III - 36	08/14/02
S06 of 82194	I-75	Fort St.	299	123	50	Steel 39-in. plate Girder	08/21/02
S26 of 50111	I-94	Metro PKW	202	126	19	W 27 x 146	09/16/02
S20 of 50111	I-94	Little Mack	222	135	52	Steel 43-in. plate Girder	09/23/02
S05 of 82025	Conner Rd.	I-94	171	57	11	W 36x150 W27x94	11/04/02

## 5.2 CONCRETE MIX DESIGN, FRESH CONCRETE PROPERTIES, AND AMBIENT ENVIRONMENTAL CONDITIONS

The concrete mix designs for all the bridges monitored during deck placement are given in Table 5-2; the mix designs were obtained from the contractor. The fresh concrete properties for each bridge monitored during deck placement were measured in the field and are shown in Table 5-3. Ambient temperature and ambient relative humidity were measured periodically throughout the casting time of the deck placement. Table 5-4 shows the starting and ending temperature and humidity for each placement with the respective times of casting.

**Table 5-2. Concrete Mix Designs for Bridges Monitored during Deck Placement**

Bridge ID	Cement [Type 1] (lbs)	Water (lbs)	Coarse Aggregate (Dry)	Fine Aggregate (Dry)	Air Entrainer	Water Reducer	Retarder
S05 of 82191	658	270	1769	1175	AEA-92* (6.6 OZ)	WR-91** (39.48 OZ)	None
S06 of 82194	658	270	1769	1175	AEA-92* (8.54 OZ)	WR-91** (19.70 OZ)	None
S26 of 50111	658	275	1744 (SSD)	1096 (SSD)	MB MICRO AIR* (4.5 OZ)	MB 997*** (52.60 OZ)	MB 200N (26.3 OZ)
S20 of 50111	658	275	1744 (SSD)	1096 (SSD)	MB MICRO AIR* (4.5 OZ)	MB 997*** (52.60 OZ)	MB 200N (26.3 OZ)
S05 of 82025	658	272	1648	1220	AEA-92* (6.6 OZ)	WR-91** (39.48 OZ)	RET 75 (26.3 OZ)

\* Micro air entrainer, ASTM C260

\*\* Type D, ASTM C494

\*\*\*Type F, ASTM C494

**Table 5-3. Fresh Concrete Properties of Bridges Monitored during Deck Placement**

Bridge ID	Slump (inches)	Air Content (%)	Concrete Temperature (°F)
S05 of 82191	7	7	89
S06 of 82194	5	6.5	78
S26 of 50111	5	7.4	75
S20 of 50111	5	7.2	78
S05 of 82025	4	6.2	68

**Table 5-4. Temperature & Relative Humidity over Time of Bridges Monitored during Deck Placement**

Bridge ID	Casting Date	Casting Time		Temperature (°F)		Humidity (%)	
		Start	End	Start	End	Start	End
S05 of 82191	8/14/02	21:10	23:57	77	67	65	92
S06 of 82194	8/19/02 - 8/20/02	21:10	2:20	66	59	66	94
S26 of 50111	9/16/02 - 9/17/02	20:45	2:25	62	53	61	100
S20 of 50111	9/23/02 - 9/24/02	20:33	4:28	67	56	39	73
S05 of 82025	11/4/02	8:20	16:00	56	55	35	31

### 5.3 SPECIFICATION REQUIREMENTS AND FIELD OBSERVATIONS

The requirements for the formwork, placement of steel reinforcements, placement of concrete, finishing of plastic concrete, and curing given in MDOT Section 706 of Standard Specifications for Construction will be discussed in the following sections.

#### 5.3.1 Formwork

Section 706.03 D of Standard Specifications for Construction describes the formwork requirements, some of which are:

1. *Strong, rigid, and motor-tight forms shall be built for placing, vibrating, and curing the concrete.*
2. *The forms are required to build following the exact dimensions and shall be in place until the concrete has sufficiently hardened to permit their removal.*
3. *Forms shall be securely braced to prevent movement while placing concrete.*
4. *The hardened concrete shall not be damaged while removing the forms.*

Field observation of the formwork showed no contradiction to the requirements set forth by the Standard Specifications.

#### 5.3.2 Placement of Steel Reinforcements

Section 706.03 E.4 of Standard Specifications for Construction describes the requirements for the layout of steel reinforcements. The main parts of the requirements related to the research projects are:

1. *All steel reinforcement shall be accurately placed and firmly held during concrete placement.*
2. *When placed in the work, it shall be free from dirt and reasonably free from excessive rust, loose mill scale, or other foreign material.*

Field observations indicated that the top and bottom reinforcement layers were placed and firmly held in agreement with the requirements given in the Specifications. All the reinforcements were free from dirt and other foreign materials; an example is shown in Photo 5-1.



**Photo 5-1. Deck reinforcement of I-75 over Fort Street**

### **5.3.3 Concrete Placement**

Section 706.03 H-1 of the Standard Specifications for Construction describes the requirements for concrete placement:

- 1. At the time concrete is placed, the forms, piling, and reinforcing steel shall be clean, and all sawdust, chips and other debris shall have been removed from the interior of the forms.*
- 2. Struts, stays, and braces, serving temporarily to hold the forms in correct shape and alignment, pending the placing of concrete at their location, shall be removed when the concrete placing has reached an elevation rendering their service unnecessary.*
- 3. The concrete shall be promptly placed with minimum handling to avoid segregation of the materials and the displacement of the reinforcement.*
- 4. The concrete shall be deposited in the forms in layers of suitable thickness and to as near final position as possible.*
- 5. For concrete placed by pumping, any water-cement slurry used to lubricate the inside of the discharge pipe at the beginning of a pour shall be disposed of outside the forms.*
- 6. Superstructure concrete shall not be allowed to freefall more than 6 inches to the top of reinforcing steel.*

The reinforcements as well as the interior of the formwork were cleaned before placement of concrete. The concrete crew made an effort to place the concrete uniformly and in its final position. Shovels were sometimes used to spread concrete from one location to another. Temporary supports such as struts, stays, and braces were removed after concrete was placed in its final position. These temporary supports were removed and struck off the concrete surface with a screed before finishing was carried out using a wooden float. During the five bridge deck replacement projects, concrete was placed up to the final thickness before the finishing work commenced. However, it was hard to control the free fall within the required limit of 6 inches. Most often, free fall was about one foot. In certain instances, free fall was between two and three feet as seen in Photo 5-2.

Additionally, placement was sometimes interrupted due to delays in concrete delivery to the job site. The delay sometimes exceeded 30 minutes, documented as the records taken at the job site. Consequently, the requirements in the Specifications stating that “sufficient vibrators shall be used to properly compact the incoming concrete within 15 minutes after placing” could not be satisfied. The practice of the concrete crew was to wait until concrete arrived at the job site before continuing with vibration and finishing. This left certain portions of the concrete on the deck without proper compaction and finishing. When the new concrete arrived and was placed on the deck, the old and the new portions were then compacted together.



**Photo 5-2. Concrete placement of I-94 over Quinn road**



Photo 5-3. Concrete placement of Vreeland over I-75

#### 5.3.4 Vibration of Fresh Concrete

Section 706.03 H-1 of the Standard Specifications for Construction describes the requirements for vibration of fresh concrete.

1. *Mechanical, high frequency internal vibrators shall be used to consolidate the concrete during and immediately after depositing.*
2. *When epoxy coated or other coated reinforcement is used, the vibrator head shall be rubber coated to prevent damage to the coating.*
3. *The consolidation of concrete by hand methods will be permitted only where the use of vibratory equipment is not feasible.*
4. *The vibrators shall be of a type approved by the Engineer and shall be capable of visibly affecting an approved mixture for a distance of at least 18 inches from the vibrator. Sufficient vibrators shall be used to properly compact the incoming concrete within 15 minutes after placing.*
5. *Vibrators shall be manipulated so as to thoroughly work the concrete around the reinforcement, embedded fixtures, and into the corners and angles of the forms.*
6. *Vibration shall be applied at the point of deposit and in the area of freshly deposited concrete.*
7. *The vibration shall be of sufficient duration and intensity to thoroughly compact the concrete, but shall not be continued so as to cause segregation.*
8. *Vibration shall not be continued at any one point to the extent that localized areas of grout are formed.*
9. *The application of vibrators shall be at points uniformly spaced and not farther apart than twice the radius over which the vibration is visibly effective.*
10. *Vibrators shall not be held against the forms or reinforcing steel, nor shall they be used for flowing the concrete or spreading it into place.*

*11. Care shall be used not to disturb partially hardened concrete.*

Construction monitoring showed that vibrator applications were random rather than following a distinct pattern as required in the Specifications. In addition, vibrators seemed to be used to spread concrete into place. In Photo 5-4, the second worker from the left is vibrating the concrete.



**Photo 5-4. Vibration of fresh concrete of Vreeland over I-75**

### **5.3.5 Nighttime Casting of Superstructure Concrete**

Section 706.03 I of the Standard Specifications for Construction describes the requirements for nighttime casting of superstructure concrete.

- 1. Cast concrete deck slab pours at night with work starting between one hour after sunset and midnight or as designated by the Engineer.*
- 2. The deck pouring sequence and curing requirements shall be strictly observed as shown on the plans and outlined in these specifications.*
- 3. If approved by the Engineer, pours shown to be done simultaneously may be done consecutively that night using adequate retarder in the first pour to prevent initial set until the second pour is completed.*

According to the field observations, no discrepancy was seen between the practice and the requirements of the Specifications.



### 5.3.6 Finishing of Plastic Concrete.

Section 706.03 M of the Standard Specifications for Construction describes the requirements for finishing of plastic concrete as follows:

*Care shall be taken to avoid over-vibration or over-finishing of the completed surface. Water may be applied to the surface of the concrete as an aid to finishing only by means of an approved fog sprayer and then only when approved by the Engineer.*

Finishing of the concrete surface was in compliance with the Specifications. This observation also complied with the requirements for machine finishing (shown in Photo 5-5) and hand float surface finishing given in Section 706.03 M-1 and Section 706.03 M-2 of the Standard Specifications.



**Photo 5-5. Finishing concrete of Vreeland over I-75**

### 5.3.7 Texturing.

Section 706.03 M-3 of the Standard Specifications for Construction describes the requirements for texturing deck concrete:

1. *The final deck surface shall be grooved as soon as the deck concrete has set sufficiently to maintain a texture.*

2. *The grooves shall be constructed perpendicular to the centerline or shall be skewed, not to exceed the maximum angle of skew of the bridge.*
3. *The grooves shall be formed in the plastic concrete while the concrete is in such condition that the grooves will be formed cleanly without either slumping of the edges or tearing of the surface. The grooving shall end at a distance of 12 inches to 16 inches from the edge of the curb or barrier.*
4. *The deck shall not be grooved within 3 inches to 6 inches of the expansion or contraction joints or at the end of the slab.*
5. *The desired surface texture consists of grooves spaced on 1/2 inch centers, 1/8 inch wide, and 1/8 inch deep. Some randomness in spacing is allowed, provided that the spacing between grooves remains within the range of 1/4 inch to 1 inch.*

Texturing work was in compliance with the Specifications. Photo 5-6 shows an example of a worker applying grooves into the newly cast deck, and Photo 5-7 depicts a closer view of the newly formed grooves.



**Photo 5-6. Texturing of concrete of I-75 over Fort Street**



**Photo 5-7. Close-up of textured concrete of I-75 over Fort Street**

### **5.3.8 Curing of the Deck Concrete**

Section 706.03 N of the Standard Specifications for Construction describes the curing procedure for concrete bridge decks. It is specified that if the air temperature is below 40 °F, structural concrete shall be cured according to subsection 706.03.J. If the air temperature is 40 °F or above, structural concrete shall be cured following certain requirements, all of which are explained below.

- 1. Curing shall consist of a two-phase continuous 7-day wet cure procedure.*

The curing was applied for 7-days; however, proper precautions were not taken to ensure that it was a wet-cure operation.

- 2. Prior to commencement of concreting operations, the Contractor shall demonstrate that all curing materials and equipment are on-site and in proper operating condition.*

Only the curing compound and the sprayer were available on-site. All other materials were brought to the site the day following the placement.

- 3. The first phase of the curing procedure shall consist of a spray application of curing compound meeting the requirements specified in section 903.*

- 4. Curing compound shall be applied in a single application beginning immediately after the sheen of bleed water has left the textured concrete surface.*

During monitoring of one bridge deck placement, curing compound was applied only after completing the placement of concrete on the full deck, rather than required by the Specifications. In another instance, curing compound had not been applied when the project team left the site, which was after the casting crew completed concrete placement, leveling, and texturing.

- 5. The curing compound application rate shall not be less than 1 gallon per 150 square feet of surface.*

It was difficult to make a justifiable conclusion in this matter since it was simply assumed that the construction crew was experienced enough to meet this requirement. Photo 5-8 shows the application of the curing compound.

- 6. Application of curing compound shall progress so as not to leave more than 10 feet of textured concrete surface exposed without curing compound at any time.*

This requirement was never satisfied during any of the deck replacement projects.



**Photo 5-8. Application of curing compound of I-94 over Quinn road**

7. *The second phase of the curing procedure shall consist of covering the concrete with clean, contaminate free wet burlap as soon as the curing compound has dried sufficiently to prevent adhesion, and the concrete surface will support it without deformation, but not more than two hours after the concrete was cast.*

The concrete surface was never covered with burlap until the next day; even then the burlap was not properly wetted.

8. *A minimum of 12 hours prior to commencement of concreting operations, the burlap shall be continuously soaked in clean water.*
9. *Prior to its use, the burlap sheeting shall be draped or suspended vertically for sufficient time to remove any excess water from its surface, which may dilute or damage the fresh concrete, however, the burlap shall not be permitted to dry. The in-place burlap shall also not be permitted to dry.*

Since the burlap could not be seen at the job site, it was not able to possible to evaluate this procedure.

10. *Burlene or other similar products with impervious surfaces are not permitted.*
11. *A network of soaker hoses shall be installed over the wet burlap as soon as the concrete surface will support it without deformation.*
12. *Soaker hoses shall be perforated throughout their lengths, within the limits of curing, and shall be capable of discharging sufficient curing water to uniformly and continuously cover the entire bridge deck surface without having to be periodically relocated. Perforations shall be sized so as to prevent excessive localized discharge of water, which may damage the concrete surface.*
13. *Non-perforated hose shall be used outside the limits of the bridge deck curing.*

The following day, observations did not show any network of soaker hoses providing a continuous discharge of curing water. Unfortunately, there is no information with regard to how the burlaps covers were kept moist, given that there was not a soaker hose system.

14. *The Contractor shall demonstrate to the Engineer that the soaker hose system provides uniform and thorough coverage of the entire deck surface. A continuous layer of 4 mils polyethylene film (transparent or white color) shall then be securely placed over the entire deck surface and the soaker hose system.*

No comments on this issue.

15. *All seams shall overlap 10 inches minimum.*

This requirement was met.

16. *The water supply shall then be activated and maintained to ensure complete and uninterrupted wet curing of the entire deck surface for the remainder of the first seven days following concrete placement.*
17. *The continue-wet cure shall be maintained until the concrete has reached an age of at least 7 days, and until the concrete has attained its minimum 7-day compressive strength.*
18. *Strength results achieved prior to seven days shall not be considered basis for removal of the continuous wet cure prior to the completion of the 7-day continuous wet curing period.*

As explained above, with the lack of soaker hose system, it was assumed that there was no continuous wet cure even though the burlap was in place for a 7-day period.

19. *Heavy equipment, such as mixers and slip form machines, will not be permitted on the deck until the deck concrete has reached an age of at least 7 days and then not until the concrete has attained at least 100 percent of its minimum 28 day flexural or compressive strength.*

Barrier casting started on some bridges when the bridge decks were seven days old. Therefore, mixers, slip-form machines, and several other vehicles traveled and parked on the newly placed bridge decks.

### **5.3.9 Additional Observations**

Some additional observations are worth mentioning. The first two are related to concrete placement. On one deck with super elevation (S06 of 82194), fresh concrete did not have sufficient stiffness and therefore flowed to one side. The deck surface needed to be diamond ground in order to achieve appropriate leveling (Photo 5-9).



**Photo 5-9. Diamond ground deck surface of bridge S06 of 82194**

The second issue was common for all decks. The construction or expansion joint boundaries are quite problematic during placement. Excess concrete overflows, loses its plasticity and it is

scraped off and thrown in with the deck concrete near the joint. This creates a substandard quality concrete near the joint. Deterioration often starts at the joints. During placement, the concrete that falls off the joints should not be placed back on the deck.

In two decks (S20 of 50111 and S05 82025), the specimens prepared for the laboratory testing were not set properly at approximately 12 hours after placement. Although the concrete mix design did not indicate any excessive use of set-retarders, these observations indicate an error in the amounts used of these admixtures.

#### **5.4 VISUAL REPRESENTATION OF THE DECK CASTING PROCESS**

The data collected during construction monitoring has been analyzed with respect to time and delays and is presented below for each of the deck placements. In the case of bridge S20 of 50111, the collected data was inconsistent and difficult to interpret; therefore, it was not included in the analysis.

##### **5.4.1 Bridge ID S06 of 82194**

Figure 5-1 shows the sequence of concrete placement for the monitored sections of the deck. Each yard is color coded with respect to the amount of time required for placement of concrete in that area, and labeled with the start time. Figure 5-2 and Figure 5-3 show the information for the north and south sections in a bar chart format, allowing one to clearly see where any delays occurred. Figure 5-4 demonstrates the relationship between cumulative volume of concrete placed and elapsed time, while Figure 5-5 shows the fluctuation in placement time of concrete as it arrives on the trucks. Figure 5-6, Figure 5-7, and Figure 5-8 show data for the finishing of concrete with regard to time elapsed and observed delays. Texturing data is presented in Figure 5-9, Figure 5-10, and Figure 5-11. Information with regard to application of curing compound may be seen in Figure 5-12, Figure 5-13, and Figure 5-14. Curing was not a smooth process. It started from somewhere in the middle of north section and advanced towards the south end of the south section. Finally, the north end of the north section was completed. Figure 5-13 and Figure 5-14 illustrate this intermittent process and the delays that occurred during the process.

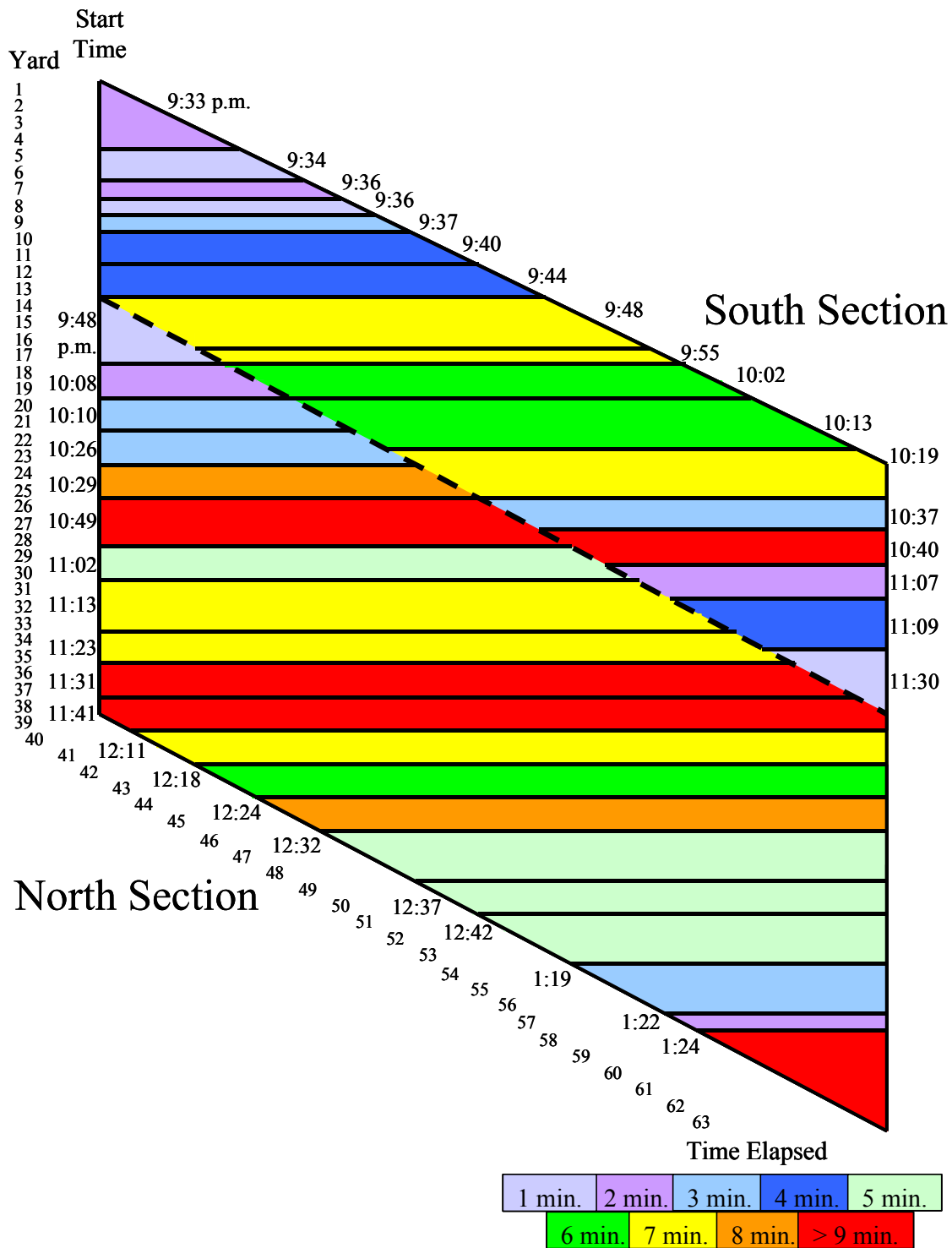


Figure 5-1. S06 of 82194 Concrete placement, time elapsed per yard



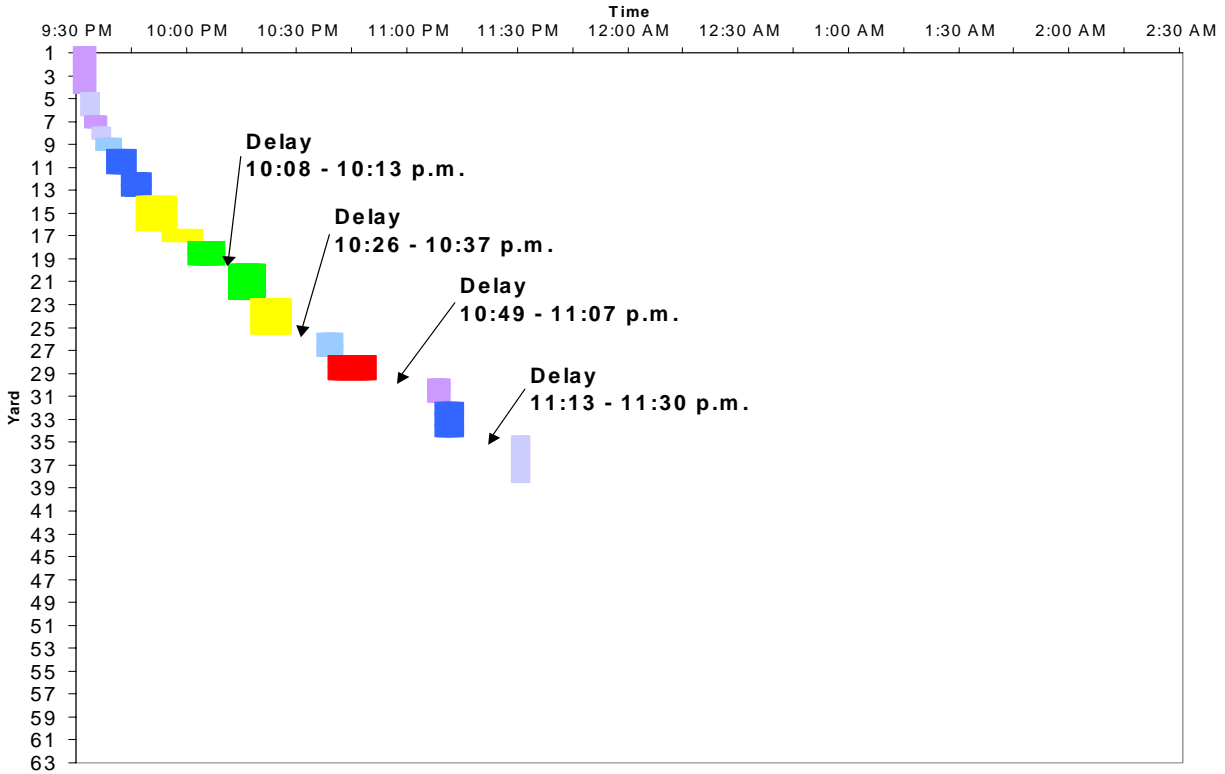


Figure 5-2. S06 of 82194, South section concrete placement time sequence

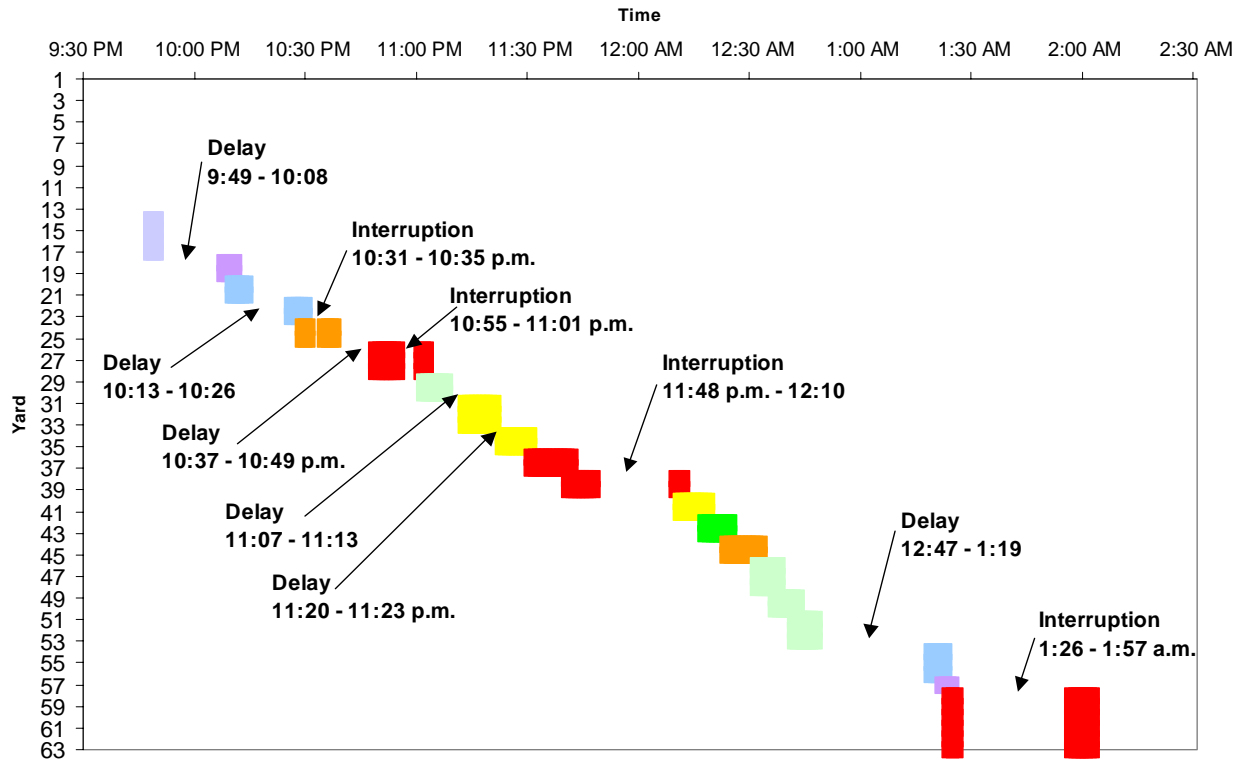


Figure 5-3. S06 of 82194, North section concrete placement time sequence

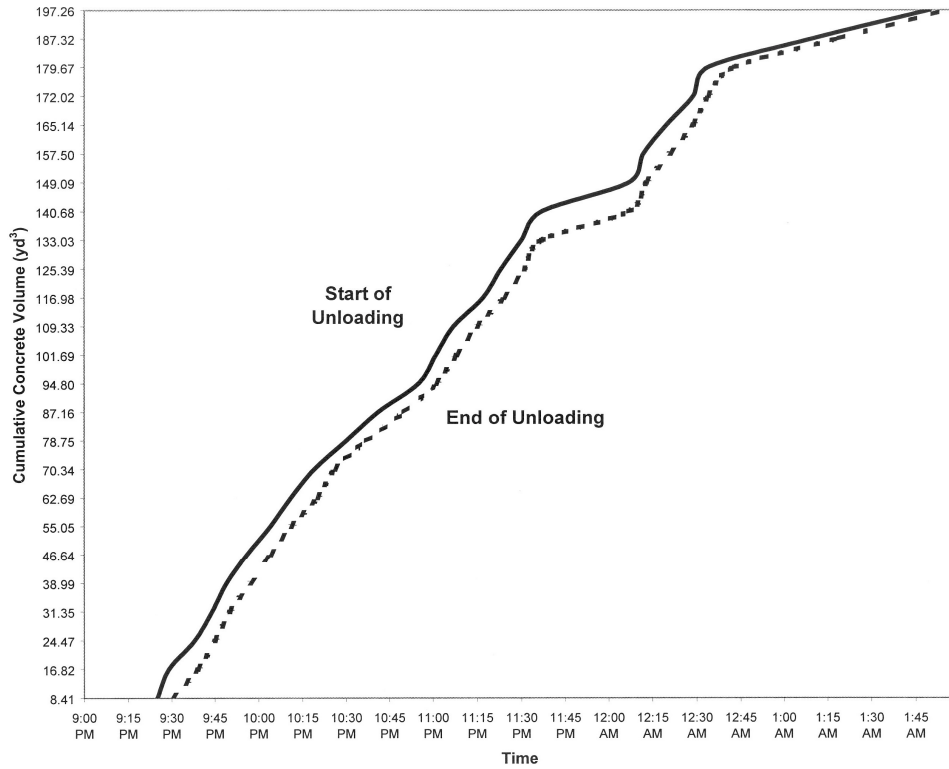


Figure 5-4. S06 of 82194, Cumulative concrete placed vs time elapsed

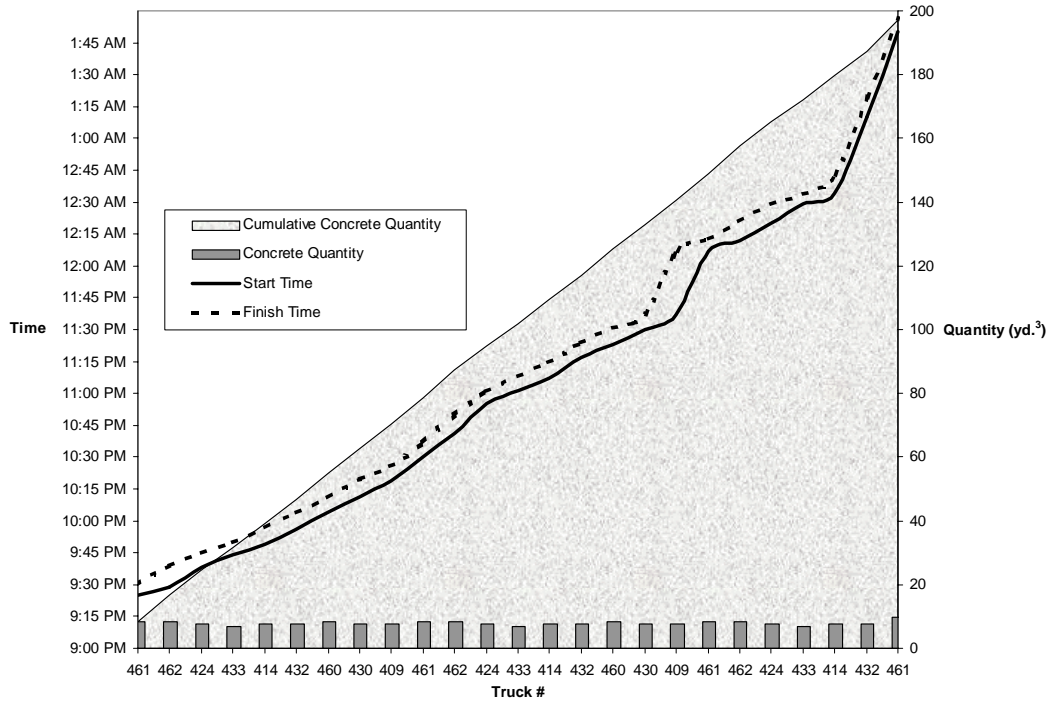


Figure 5-5. S06 of 82194, Time and volume of concrete placed vs truck arrival

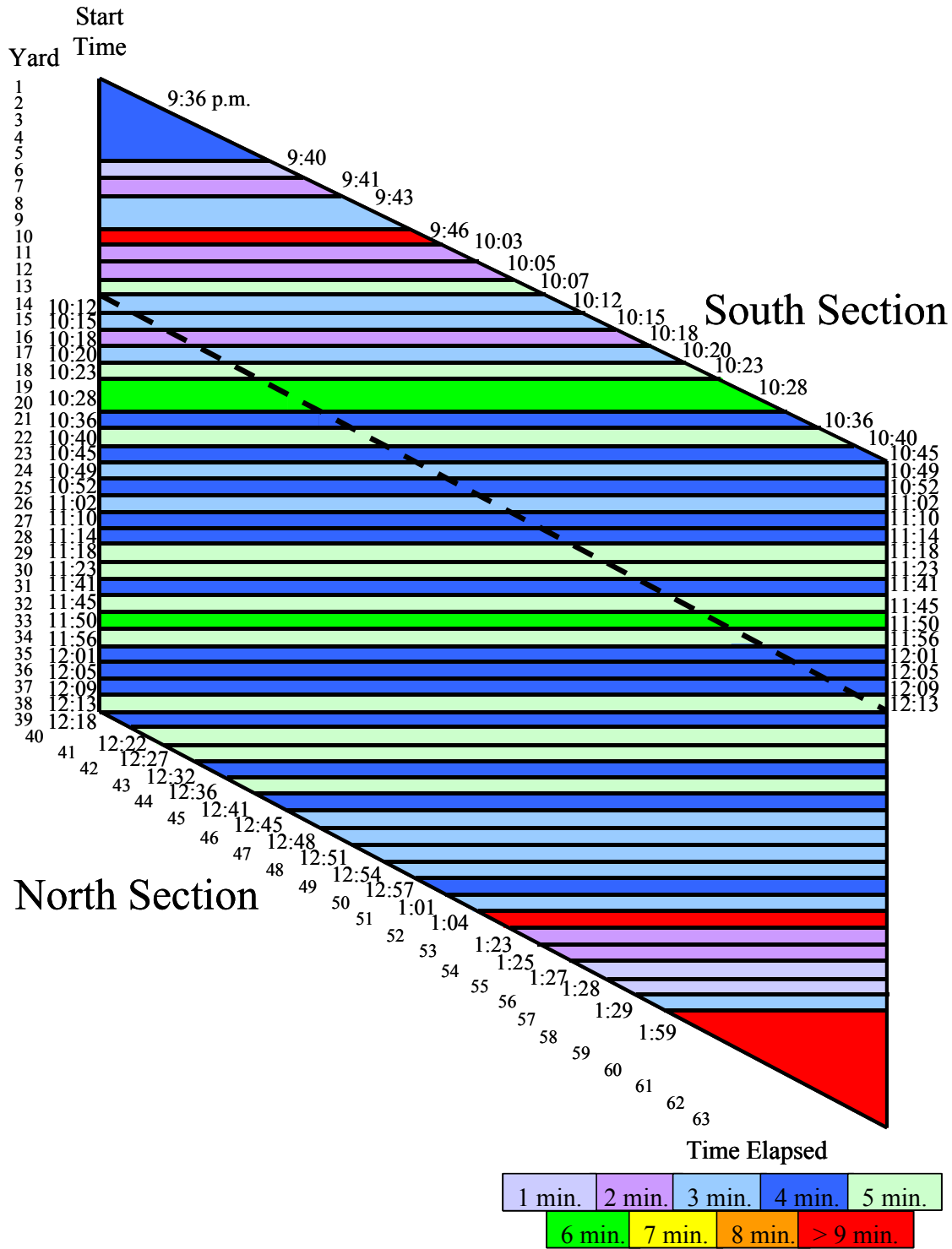


Figure 5-6. S06 of 82194, Concrete finishing, time elapsed per yard

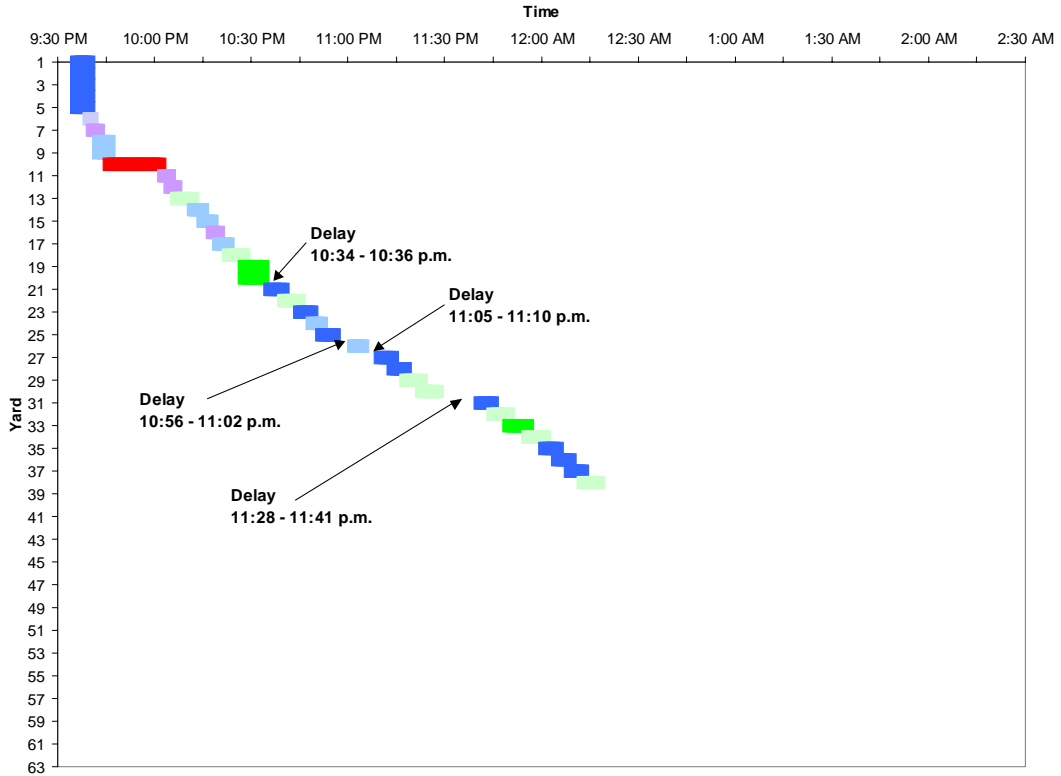


Figure 5-7. S06 of 82194, South section concrete finishing time sequence

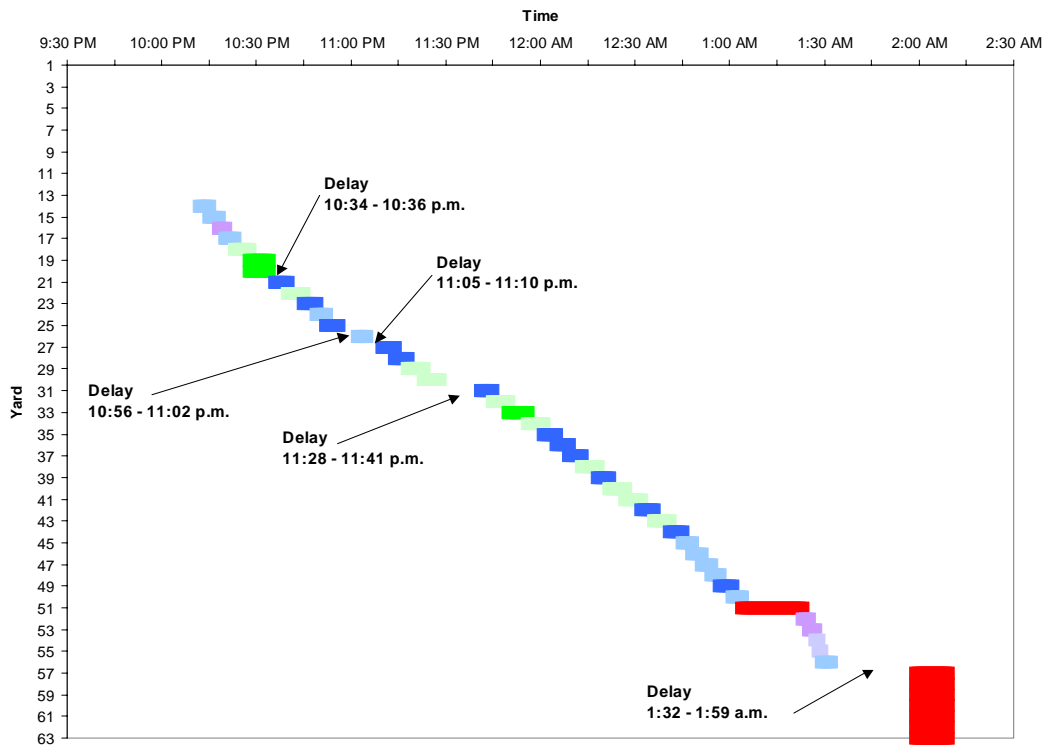


Figure 5-8. S06 of 82194, North section concrete finishing time sequence

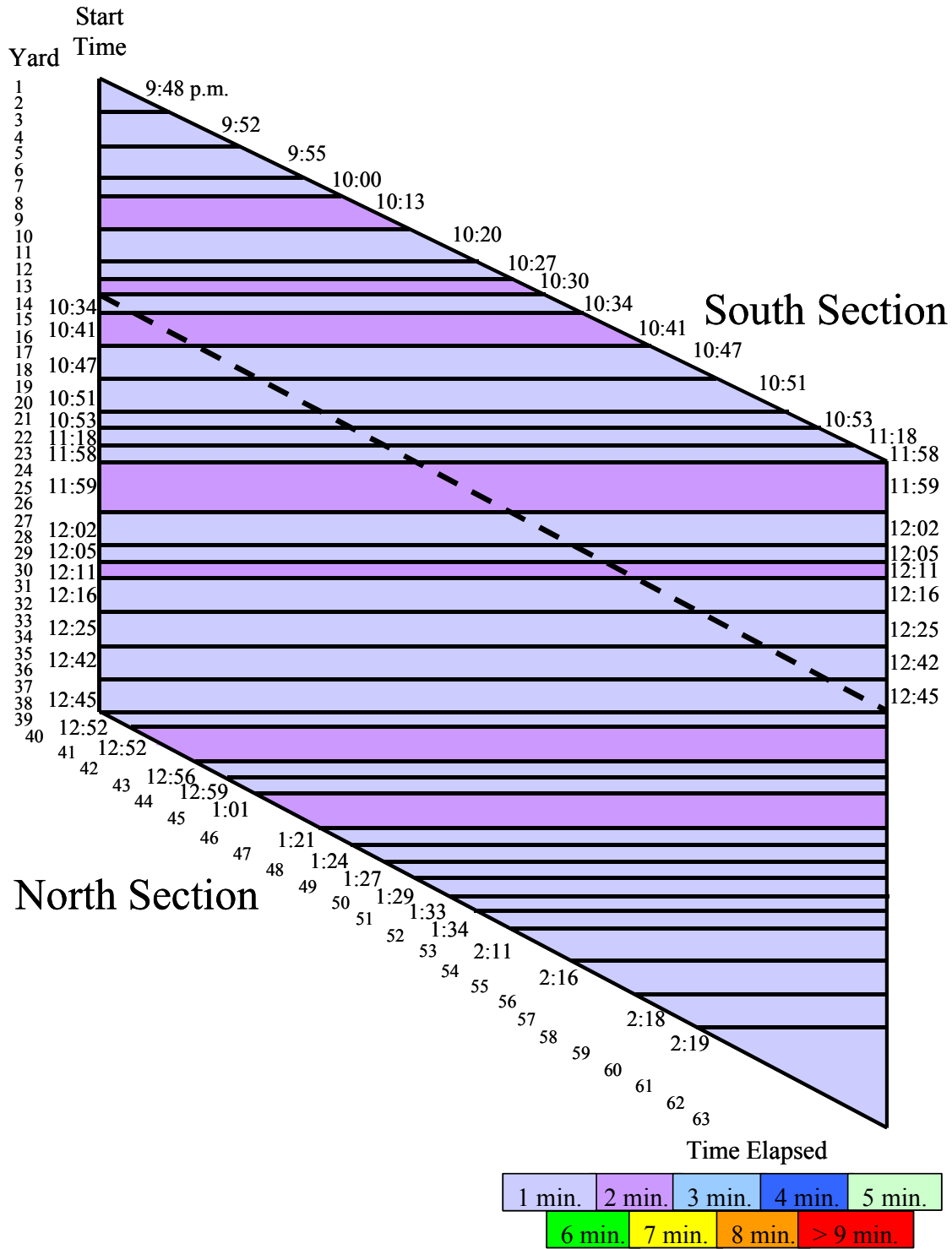


Figure 5-9. S06 of 82194, Concrete texturing, time elapsed per yard

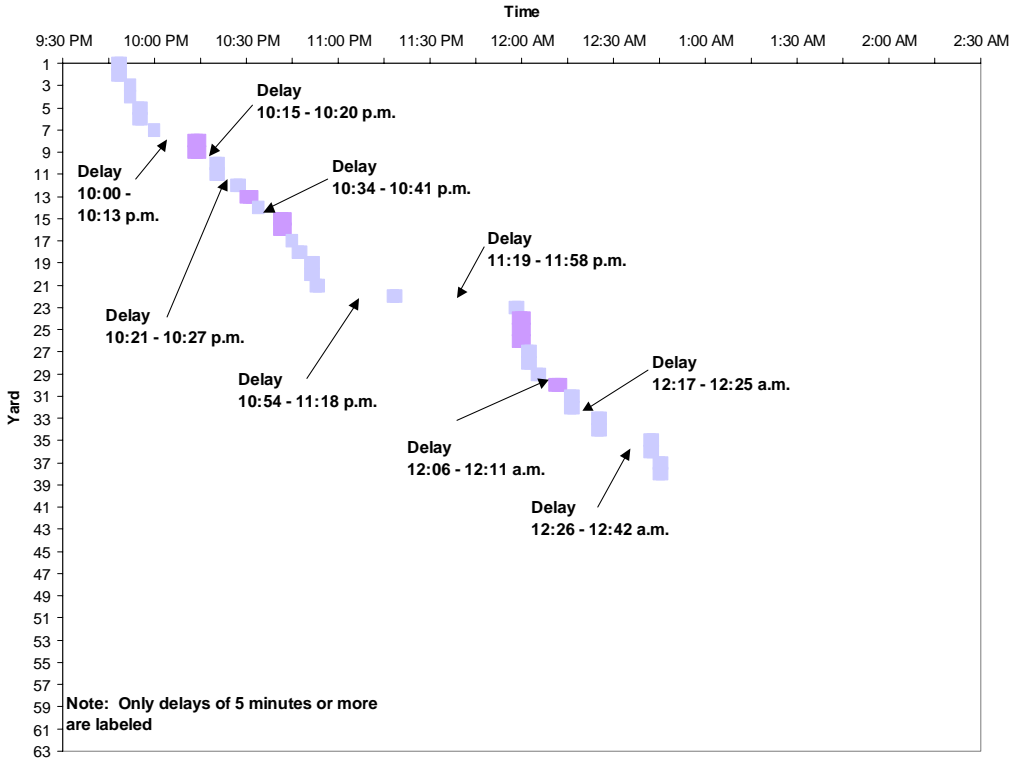


Figure 5-10. S06 of 82194, South section concrete texturing time sequence

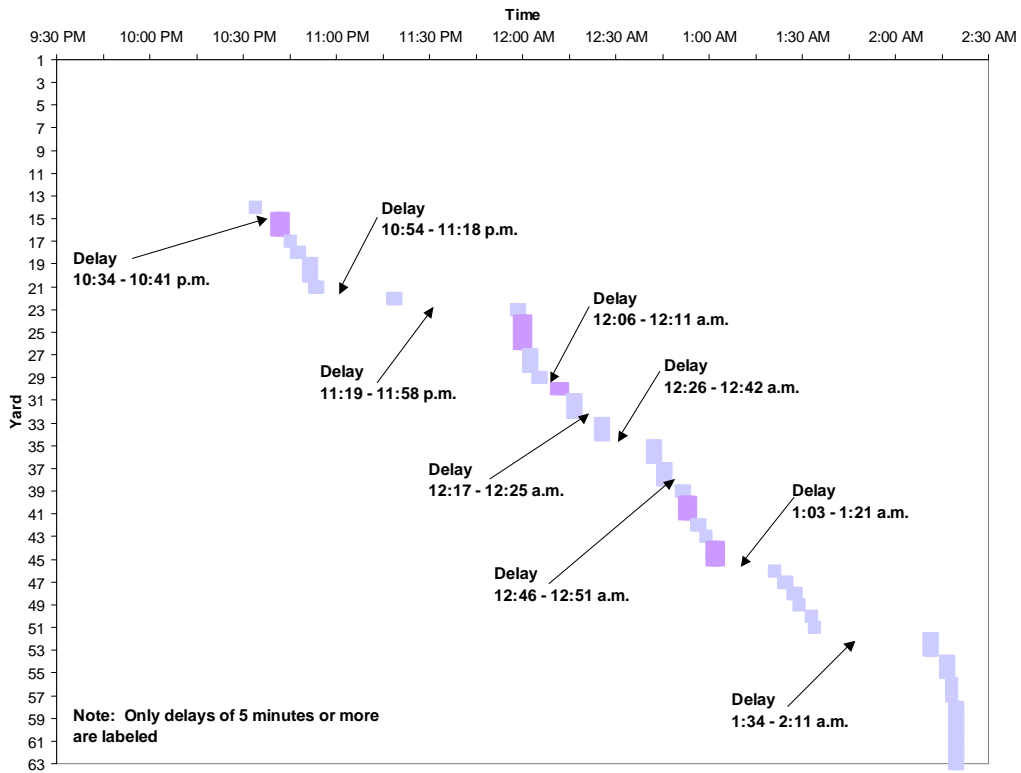


Figure 5-11. S06 of 82194, North section concrete texturing time sequence

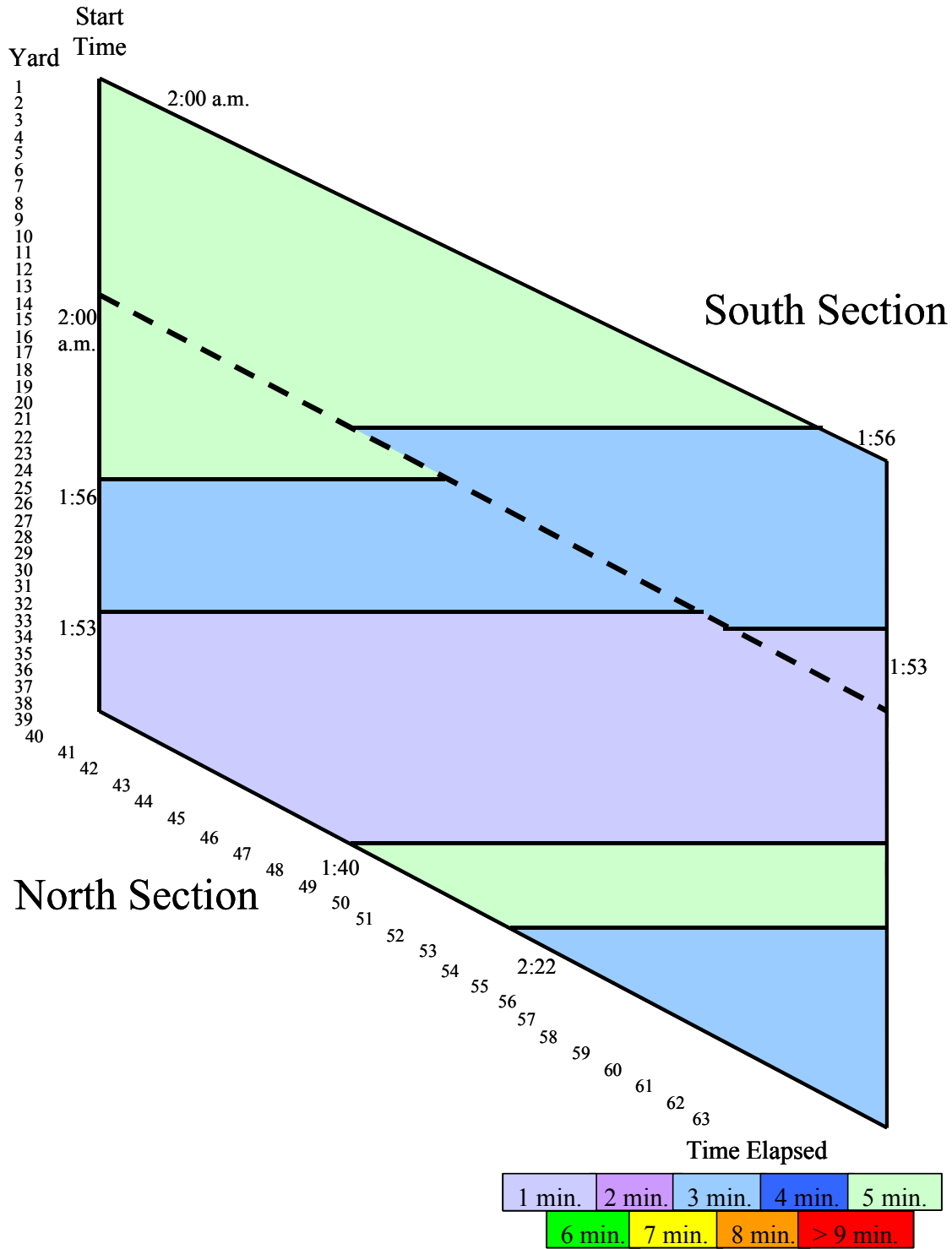
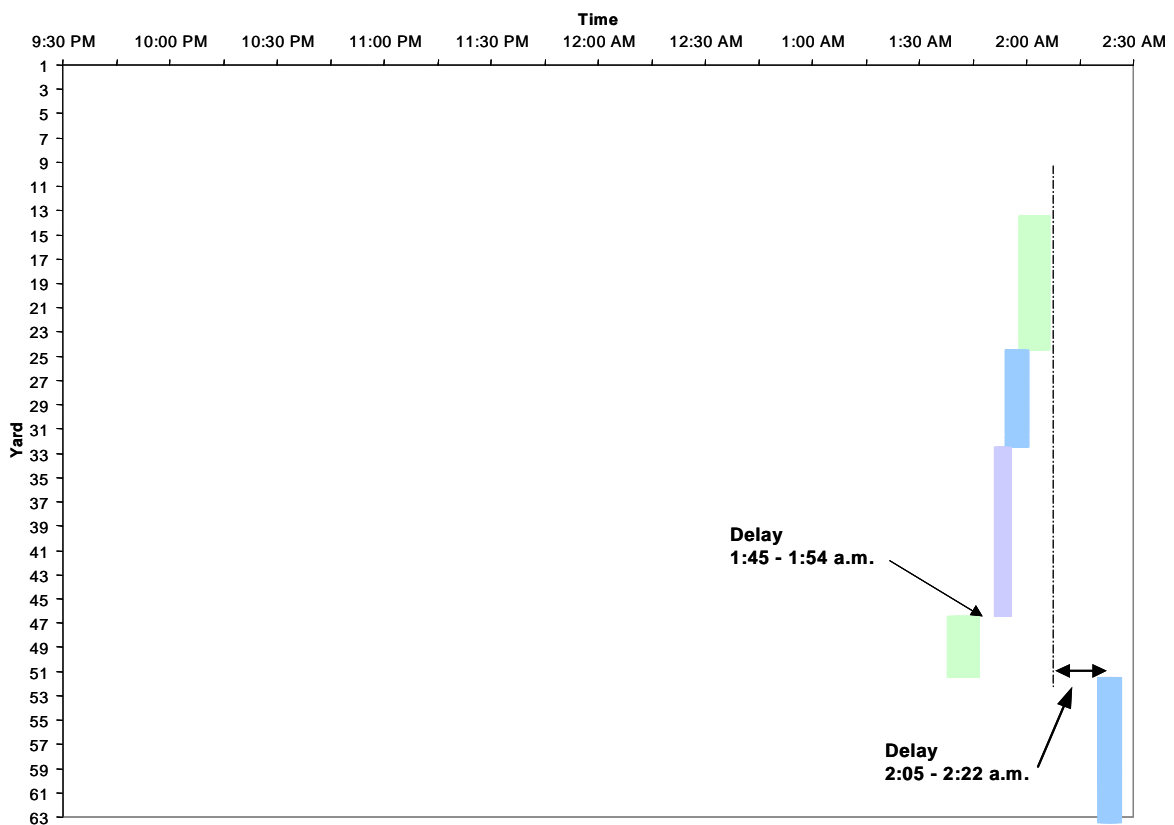


Figure 5-12. S06 of 82194, Curing compound application, time elapsed per yard



**Figure 5-13. S06 of 82194, South section curing compound application time sequence**

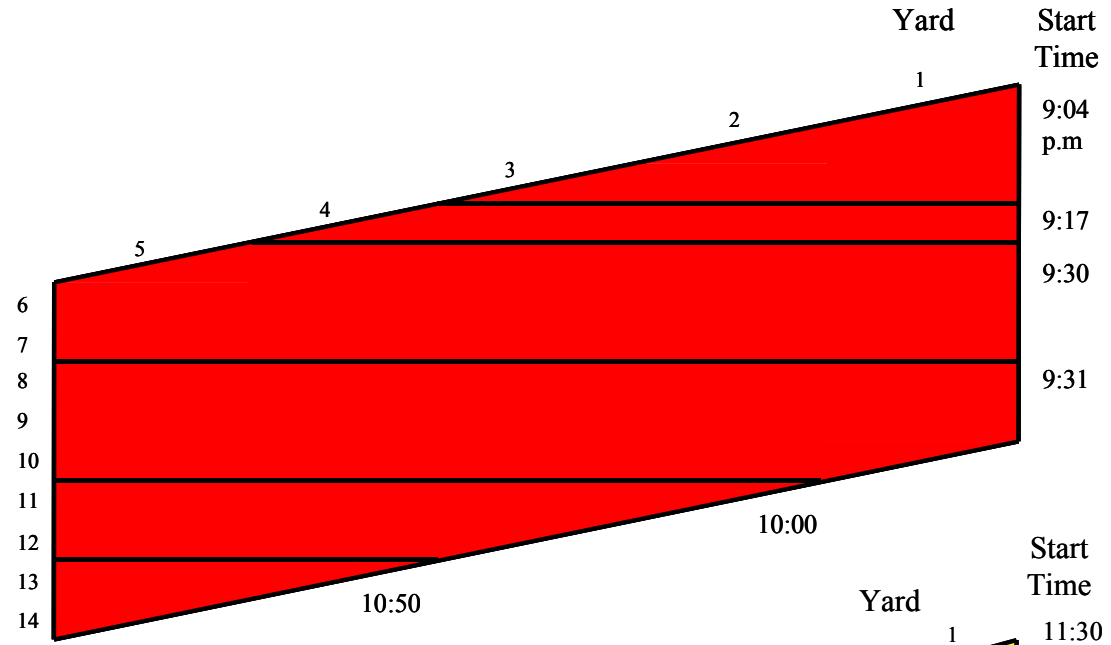


**Figure 5-14. S06 of 82194, North section curing compound application time sequence**

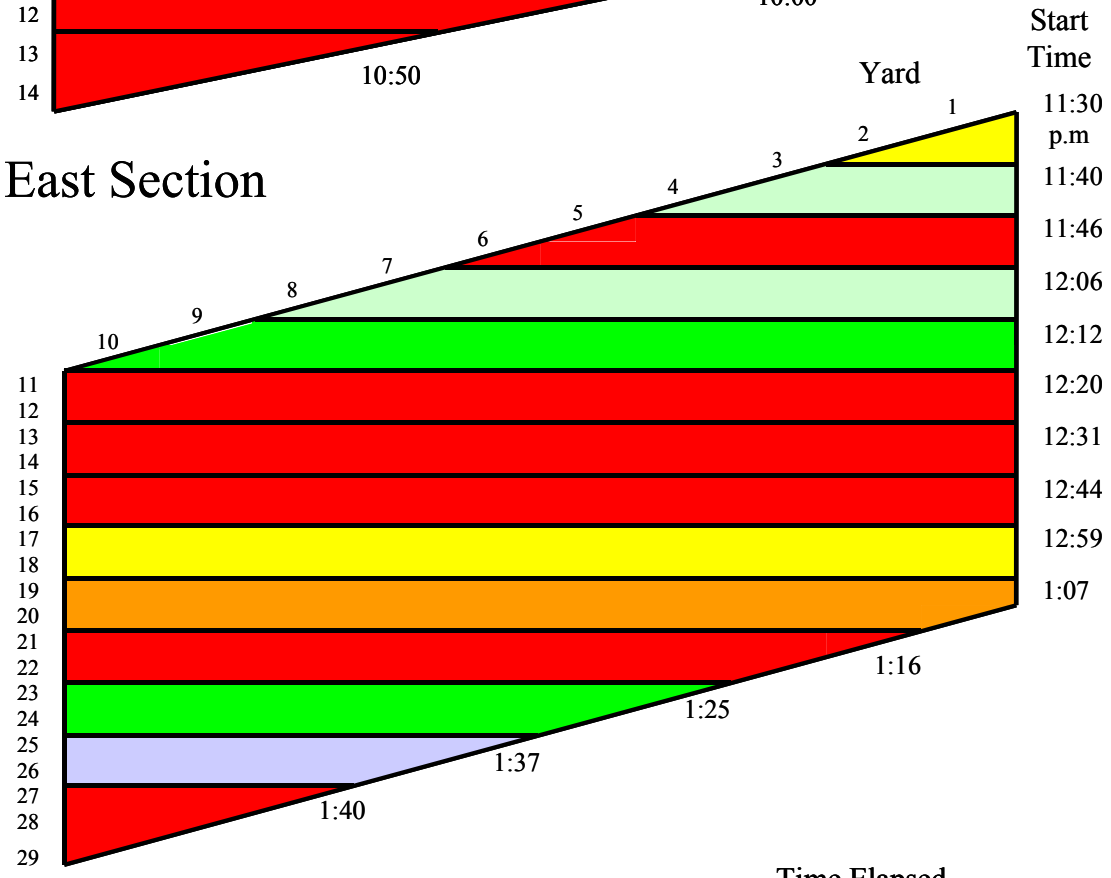


#### **5.4.2 Bridge ID S26 of 50111**

Figure 5-15 shows the sequence of concrete placement for the monitored sections of the deck. Figure 5-16 and Figure 5-17 show the information for the east and west sections in a bar chart format, allowing one to clearly see where any delays occurred. Figure 5-18 demonstrates the relationship between cumulative volume of concrete placed and elapsed time, while Figure 5-19 shows the fluctuation in placement time of concrete as it arrives on the trucks. Figure 5-20, Figure 5-21, and Figure 5-22 show data for the finishing of concrete with regard to time elapsed and observed delays. Texturing data is presented in Figure 5-23, Figure 5-24, and Figure 5-25. Information with regard to application of curing compound may be seen in Figure 5-26, Figure 5-27, and Figure 5-28.



East Section



West Section

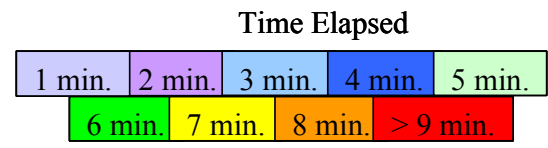


Figure 5-15. S26 of 50111, Concrete placement, time elapsed per yard

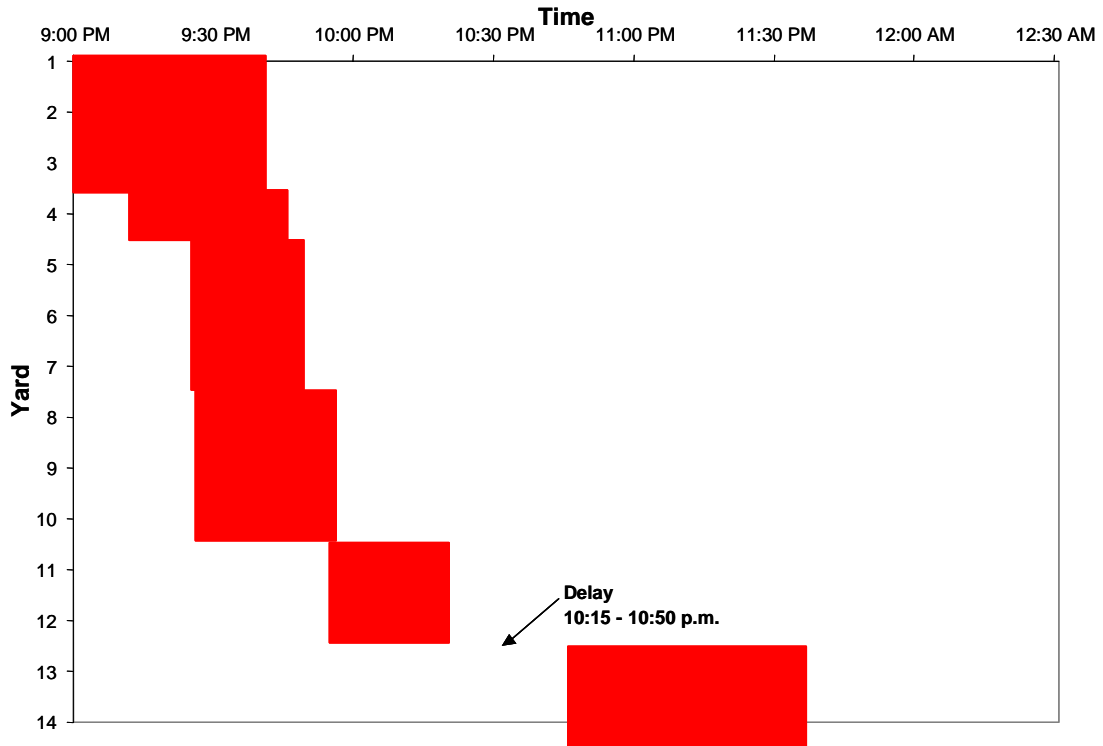


Figure 5-16. S26 of 50111, East section concrete placement time sequence

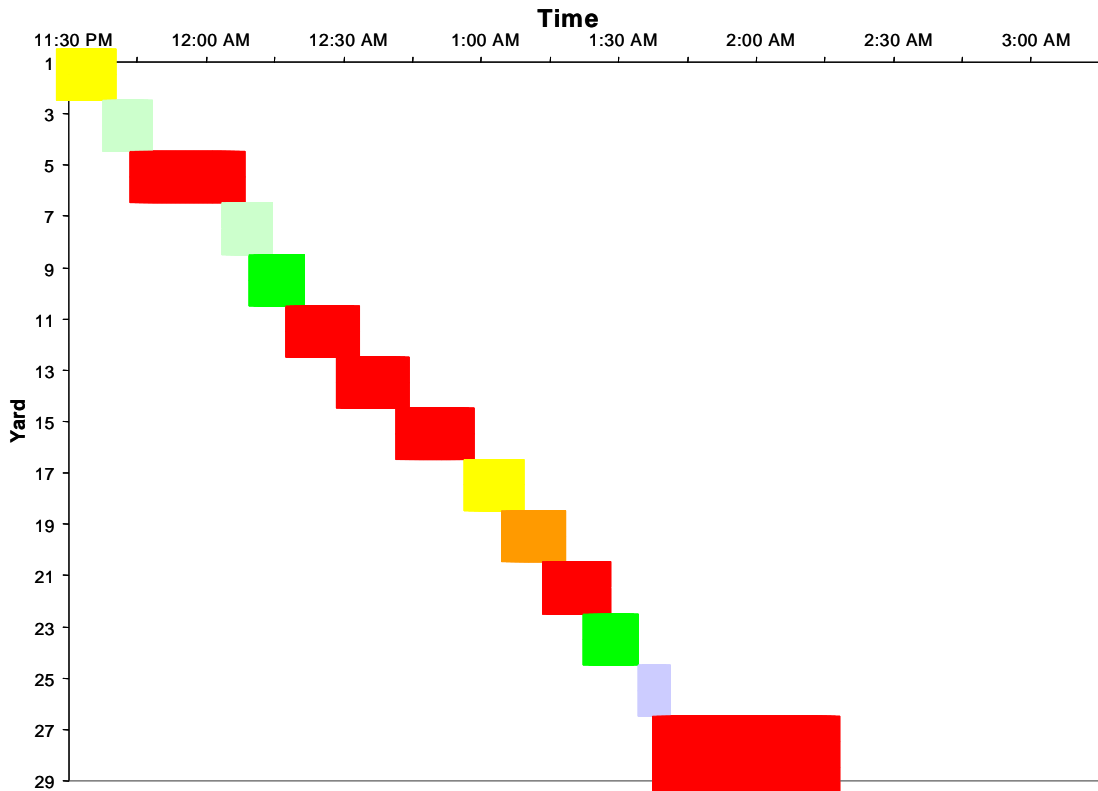


Figure 5-17. S26 of 50111, West section concrete placement time sequence

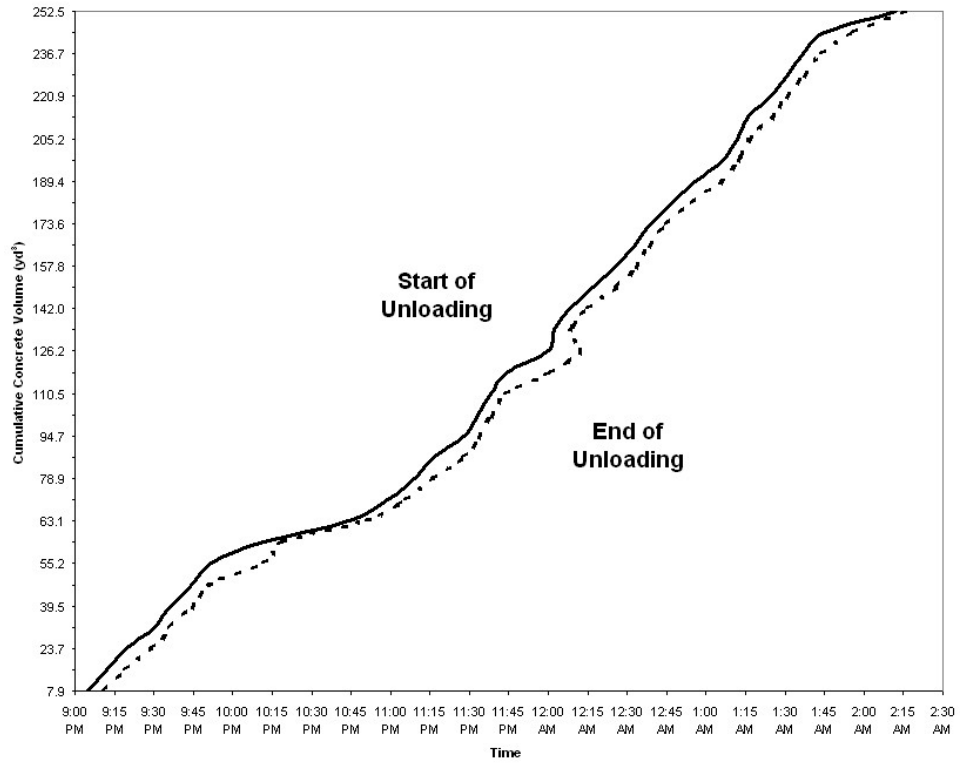


Figure 5-18. S26 of 50111, Cumulative concrete placed vs time elapsed

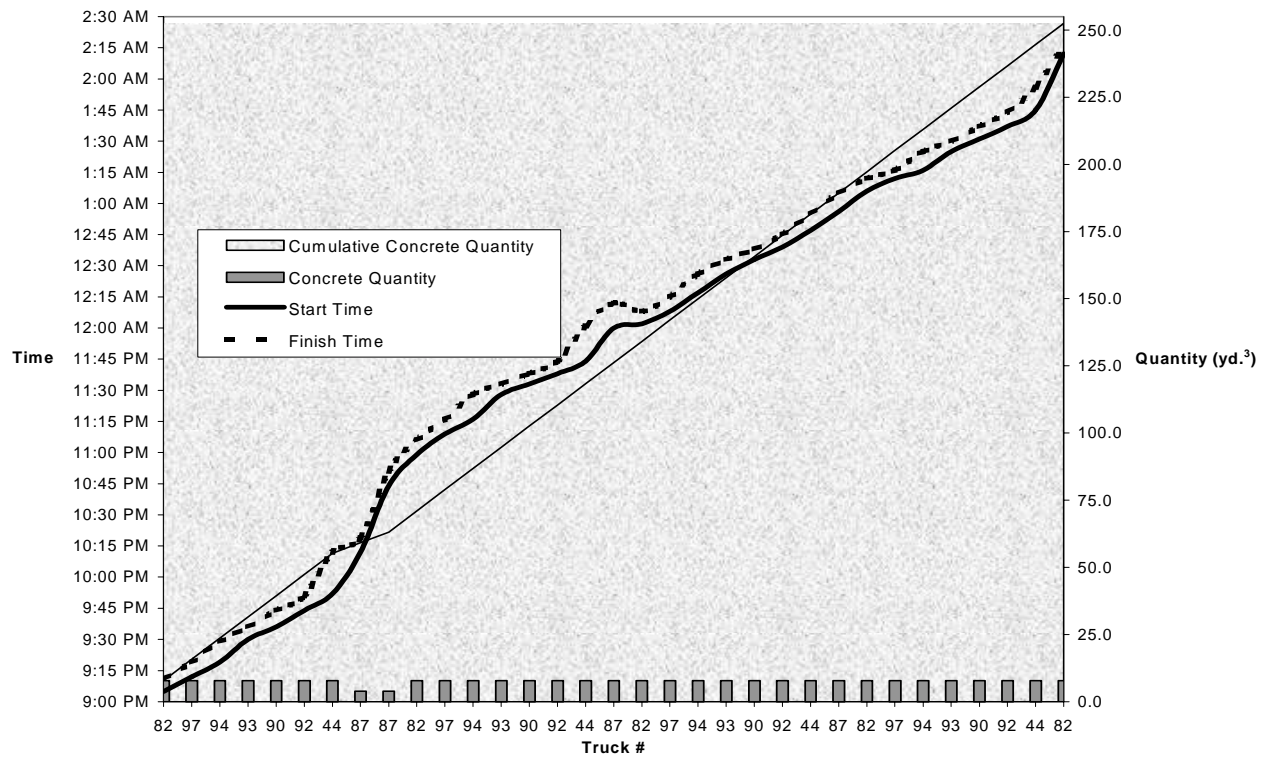


Figure 5-19. S26 of 50111, Time and volume of concrete placed vs truck arrival

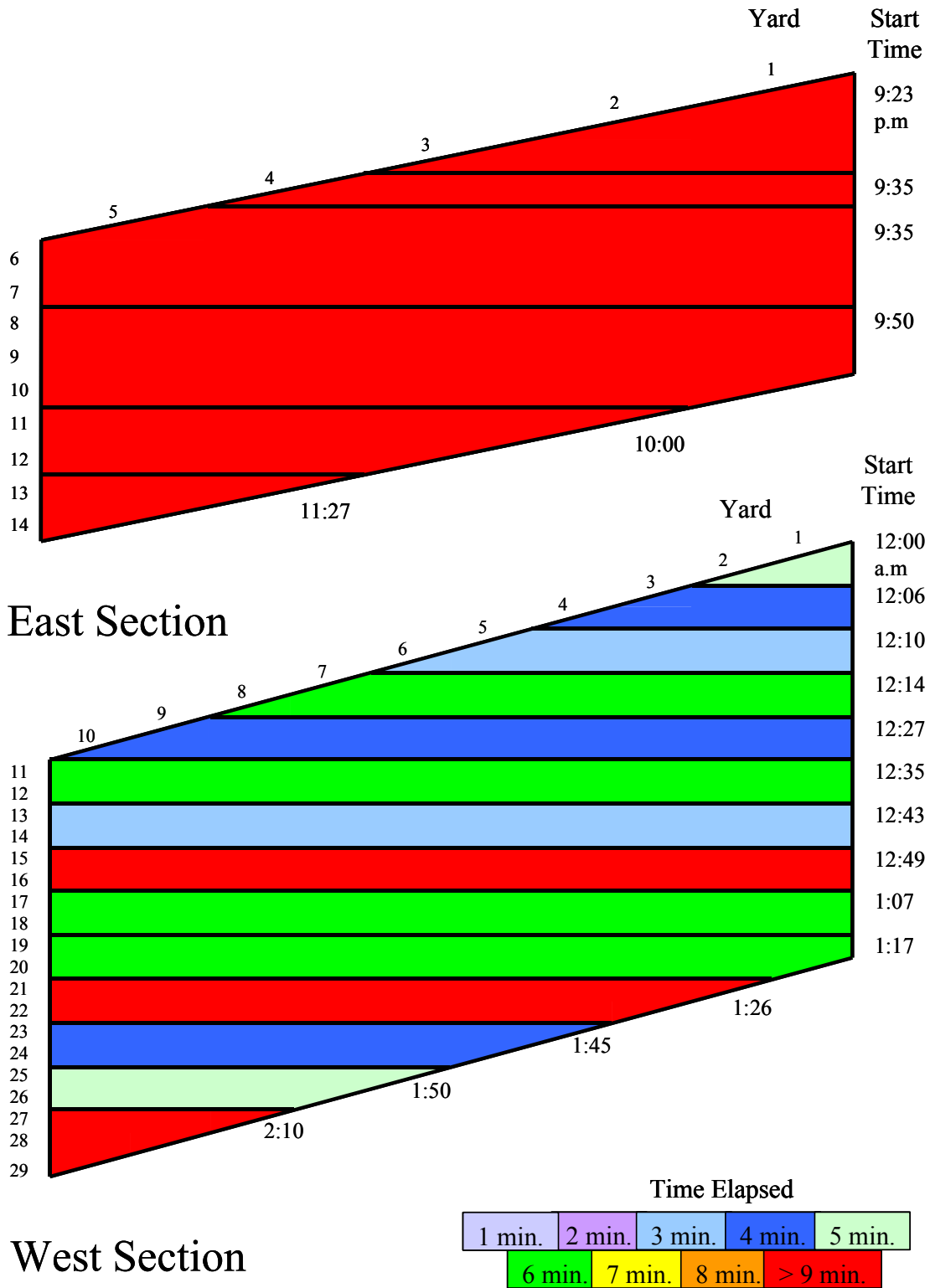


Figure 5-20. S26 of 50111, Concrete finishing, time elapsed per yard

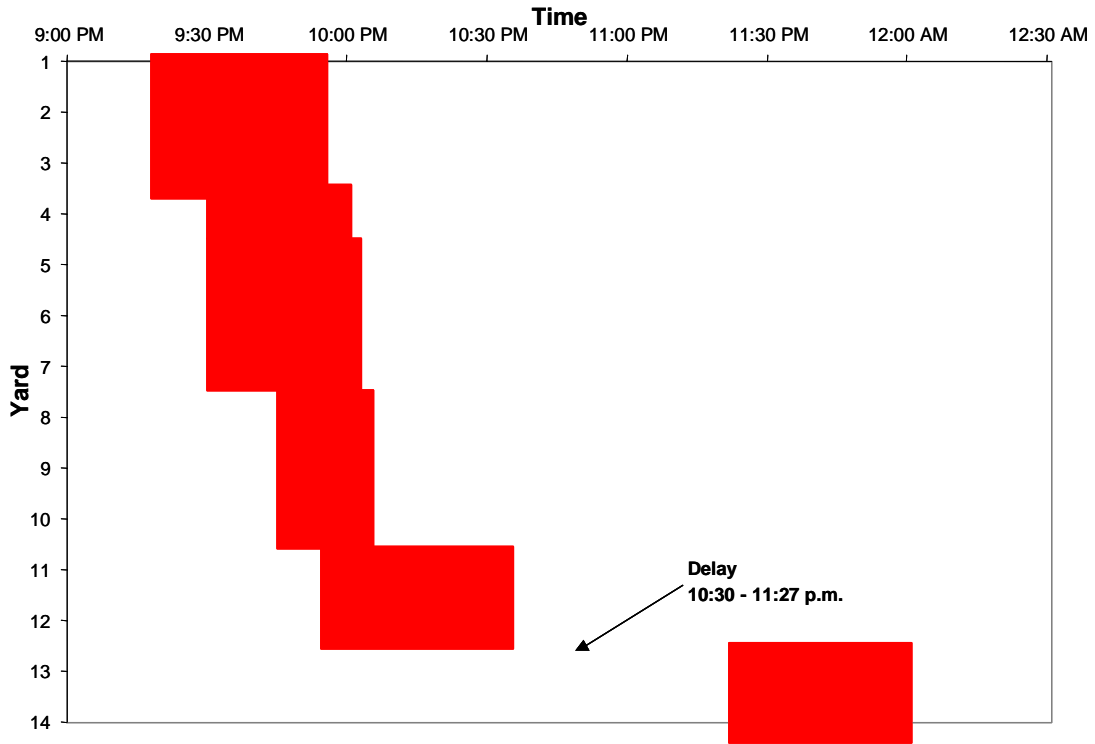


Figure 5-21. S26 of 50111, East section concrete finishing time sequence

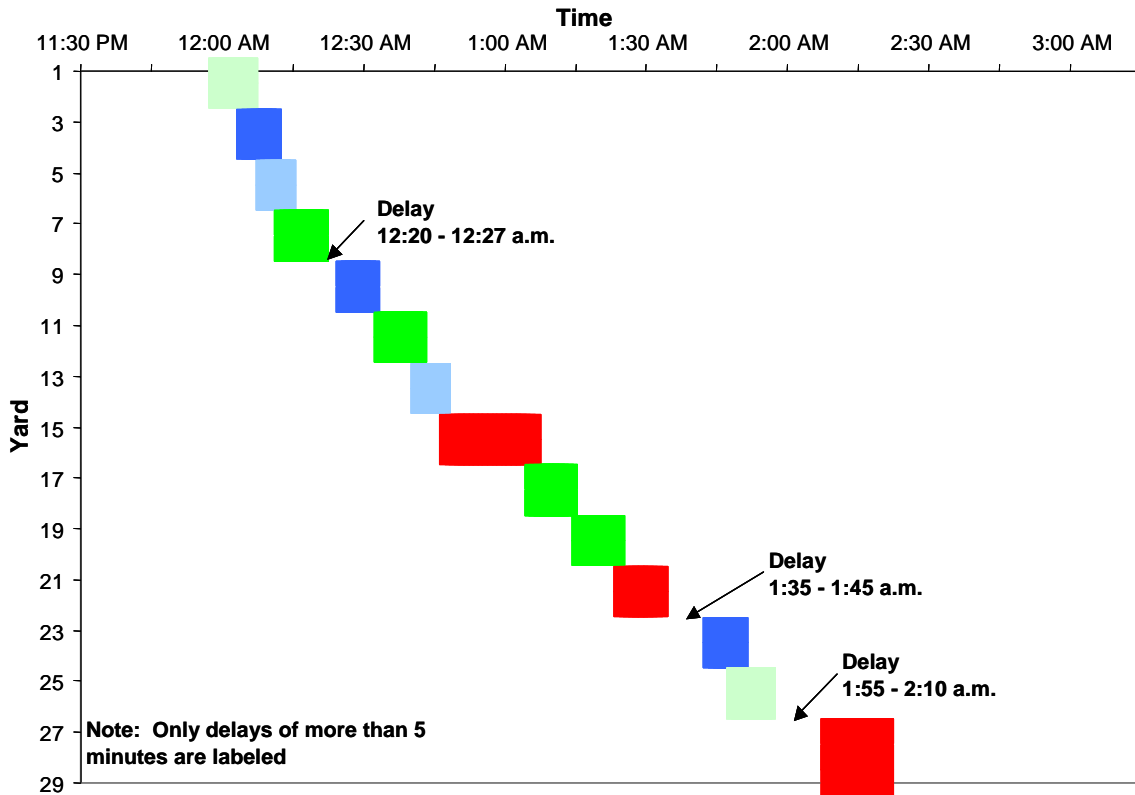
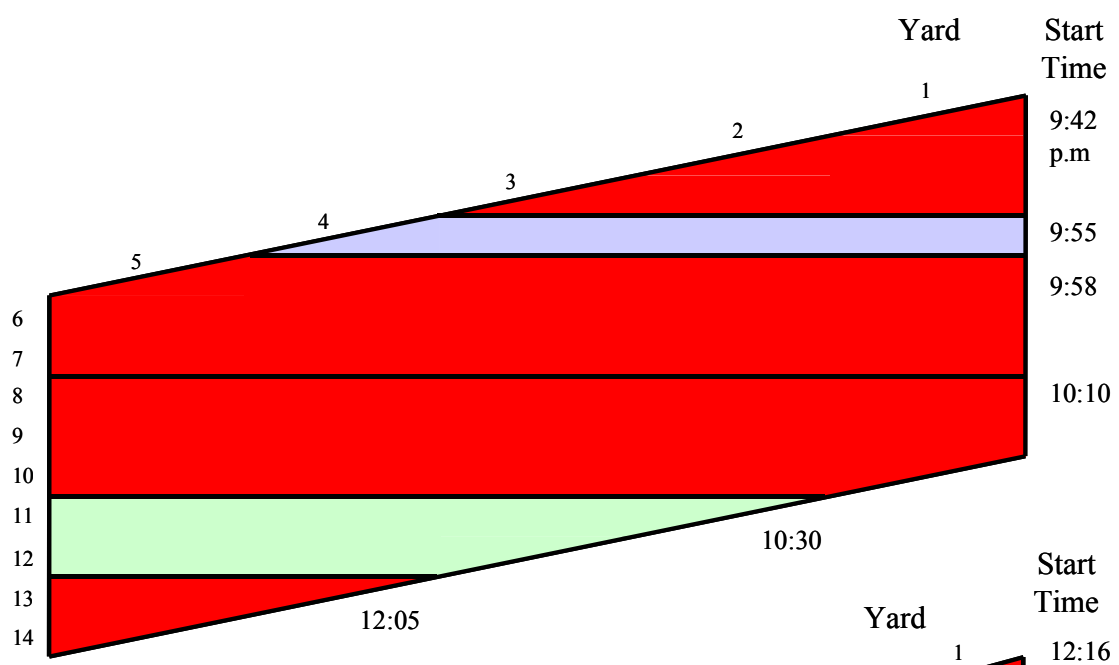
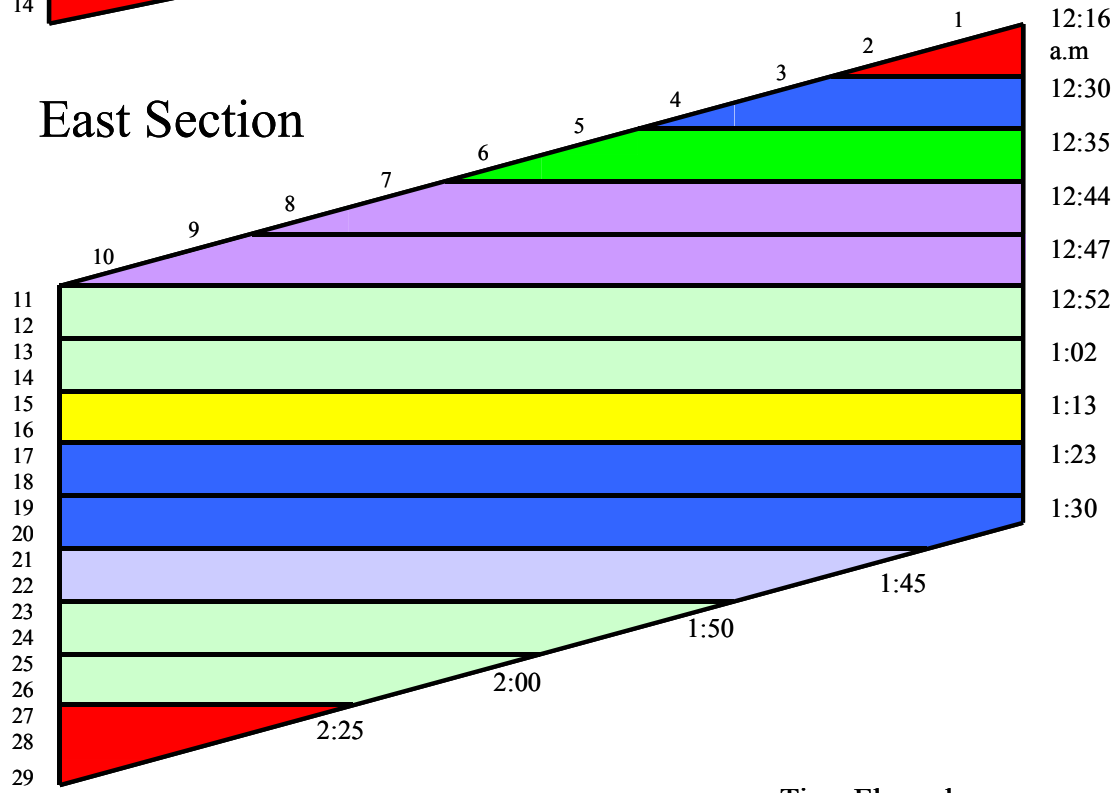


Figure 5-22. S26 of 50111, West section concrete finishing time sequence



East Section



West Section

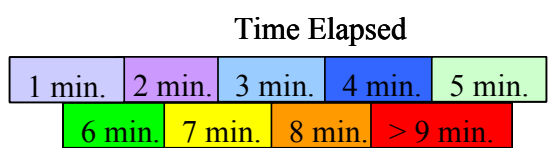


Figure 5-23. S26 of 50111, Concrete texturing, time elapsed per yard

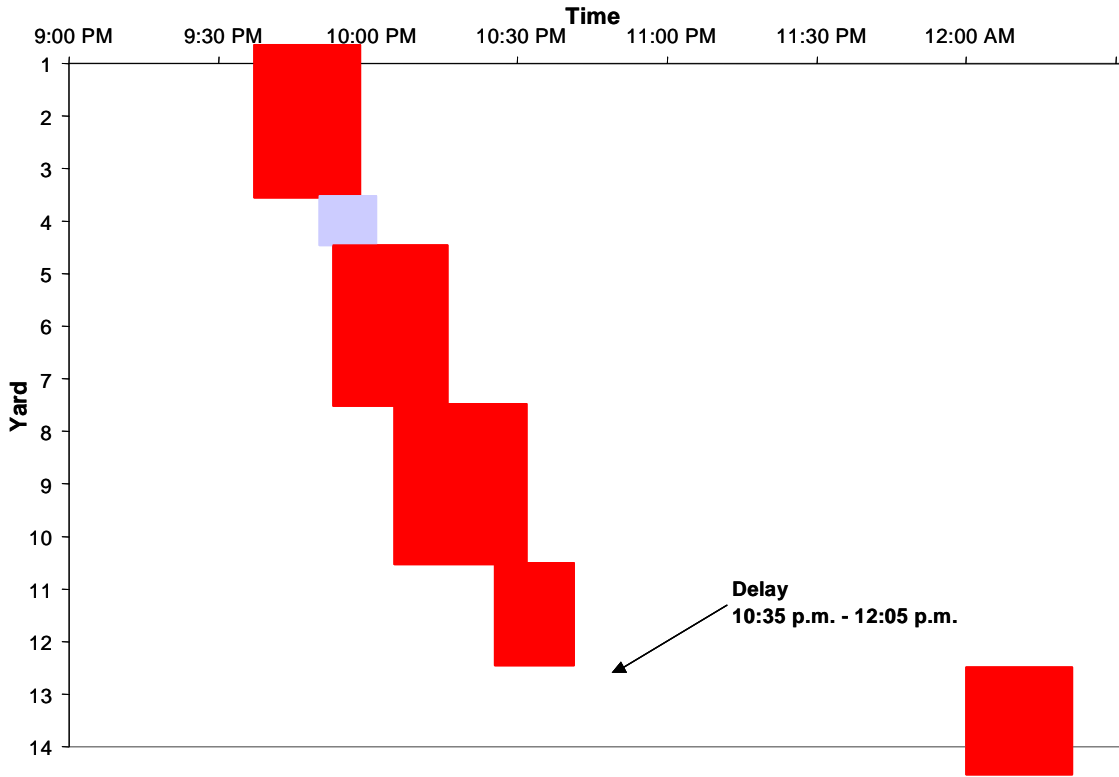


Figure 5-24. S26 of 50111, East section concrete texturing time sequence

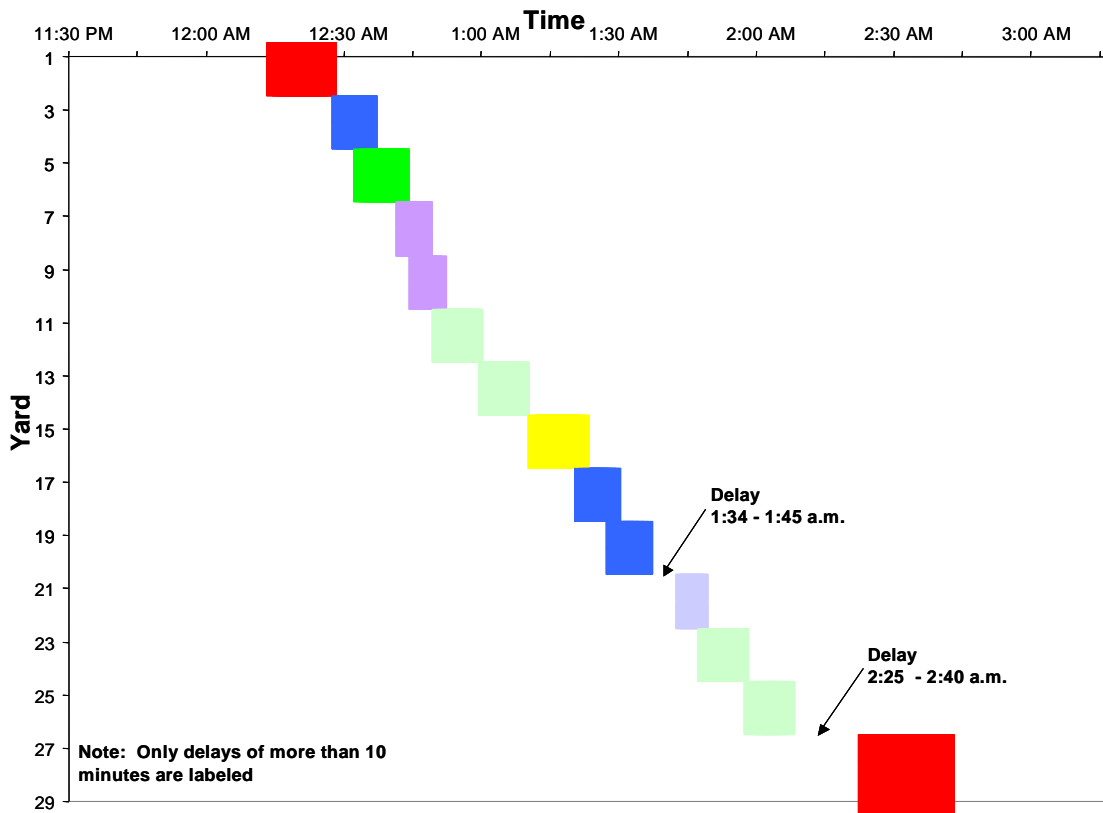
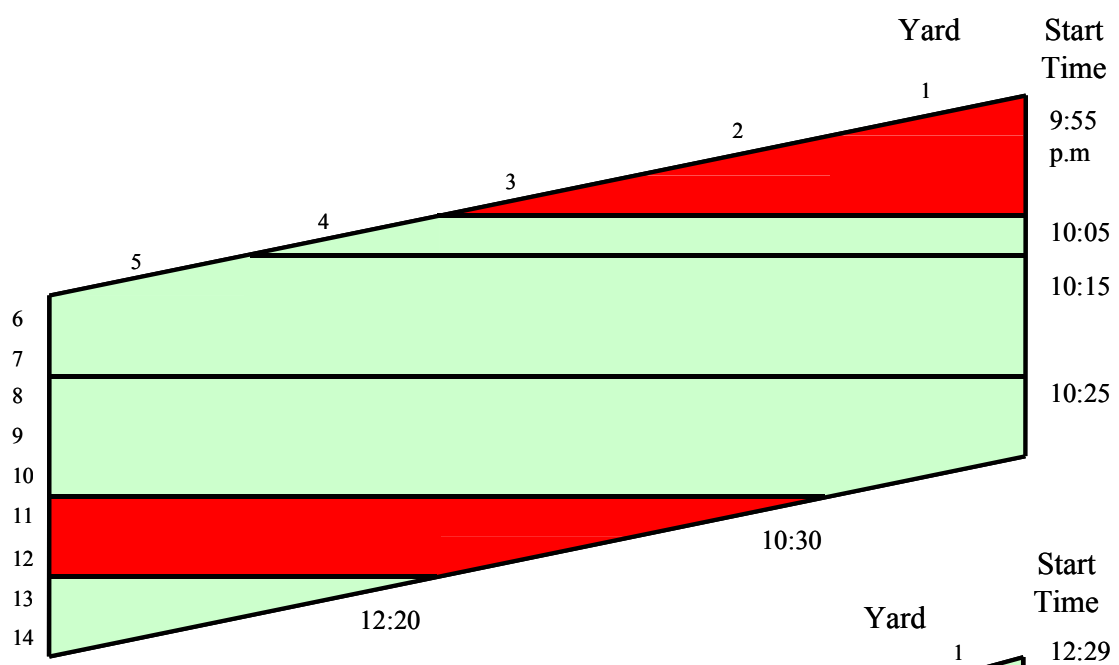
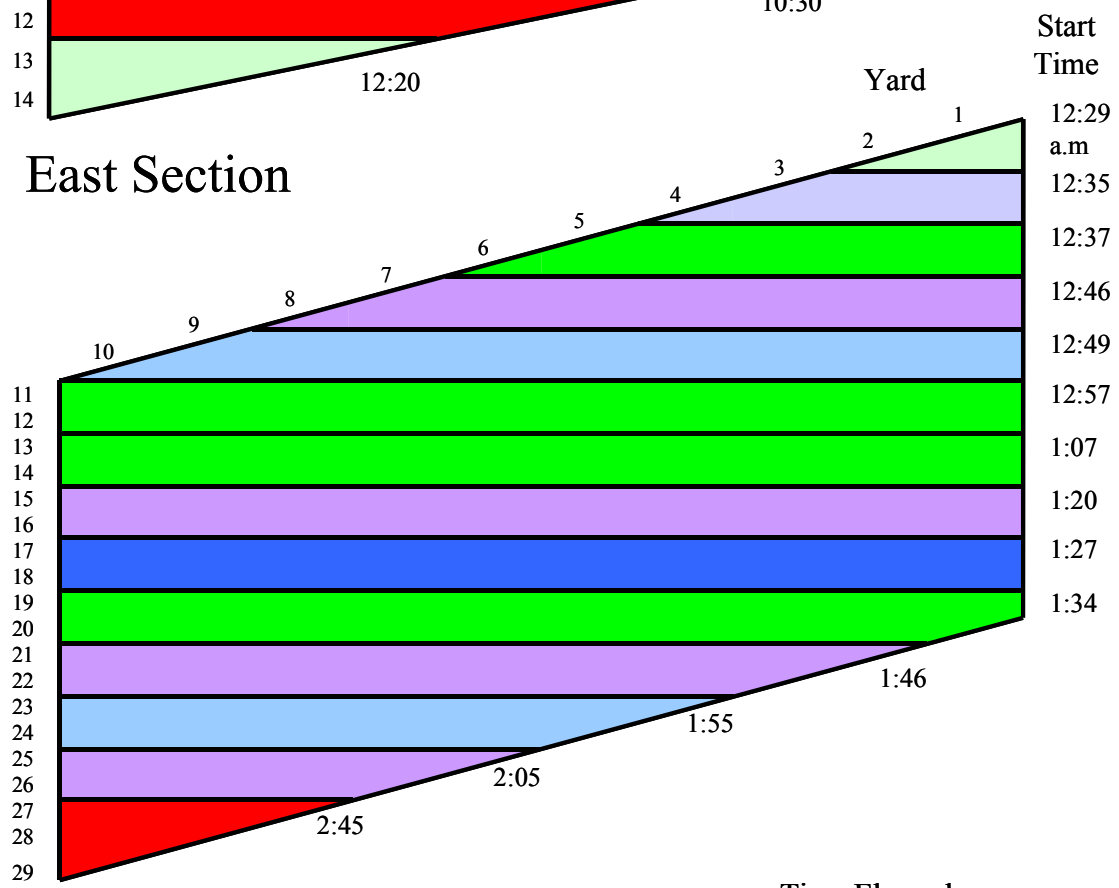


Figure 5-25. S26 of 50111, West section concrete texturing time sequence





East Section



West Section

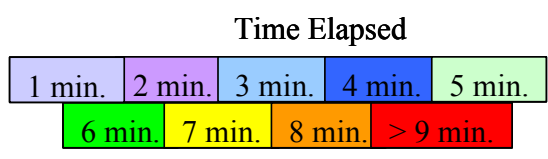


Figure 5-26. S26 of 50111, Curing compound application, time elapsed per yard

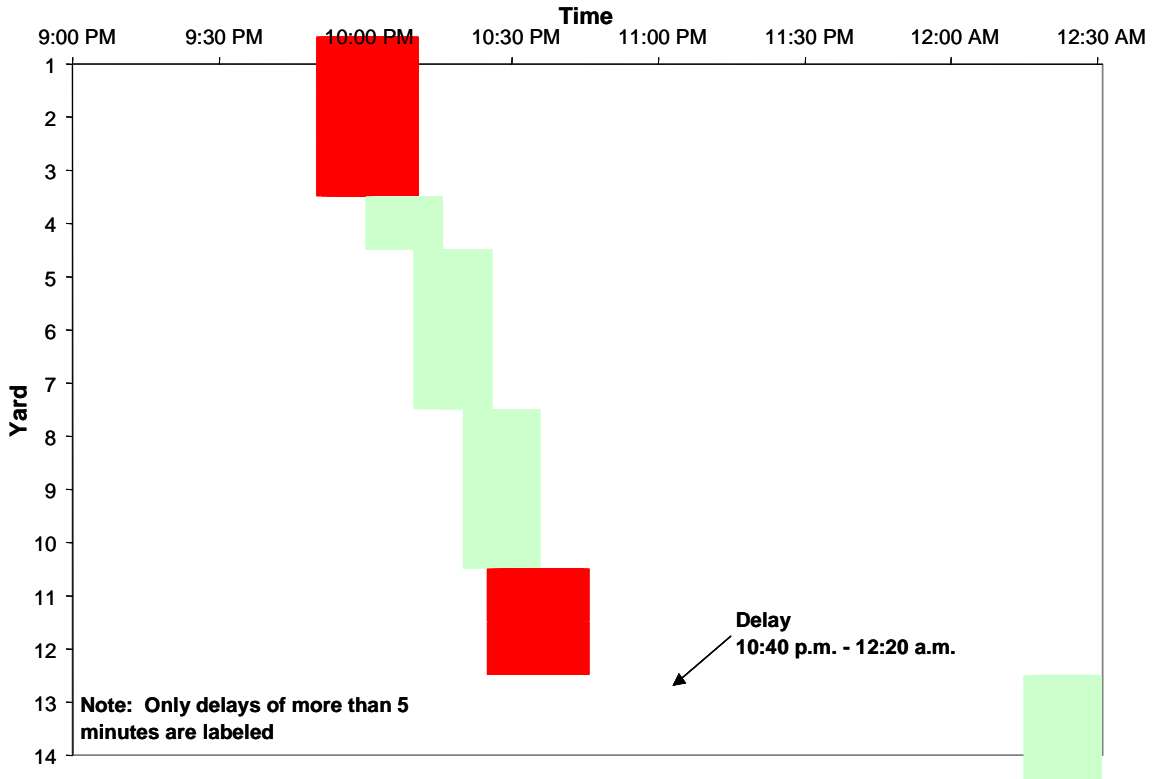


Figure 5-27. S26 of 50111, East section curing compound application time sequence

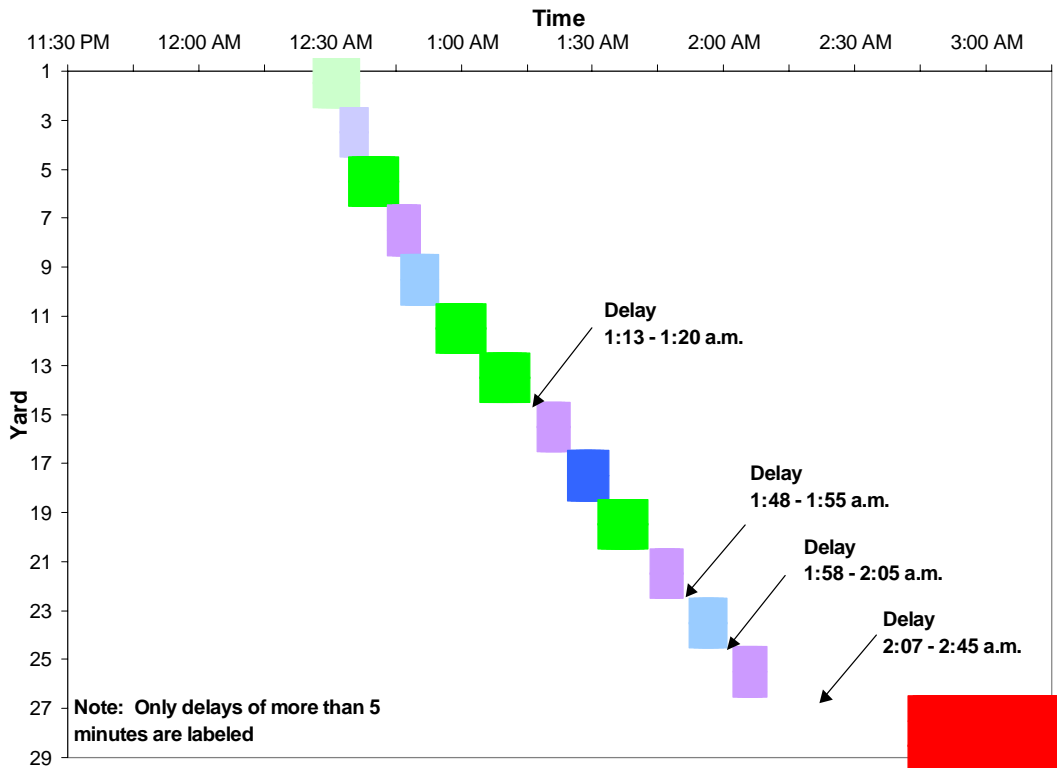
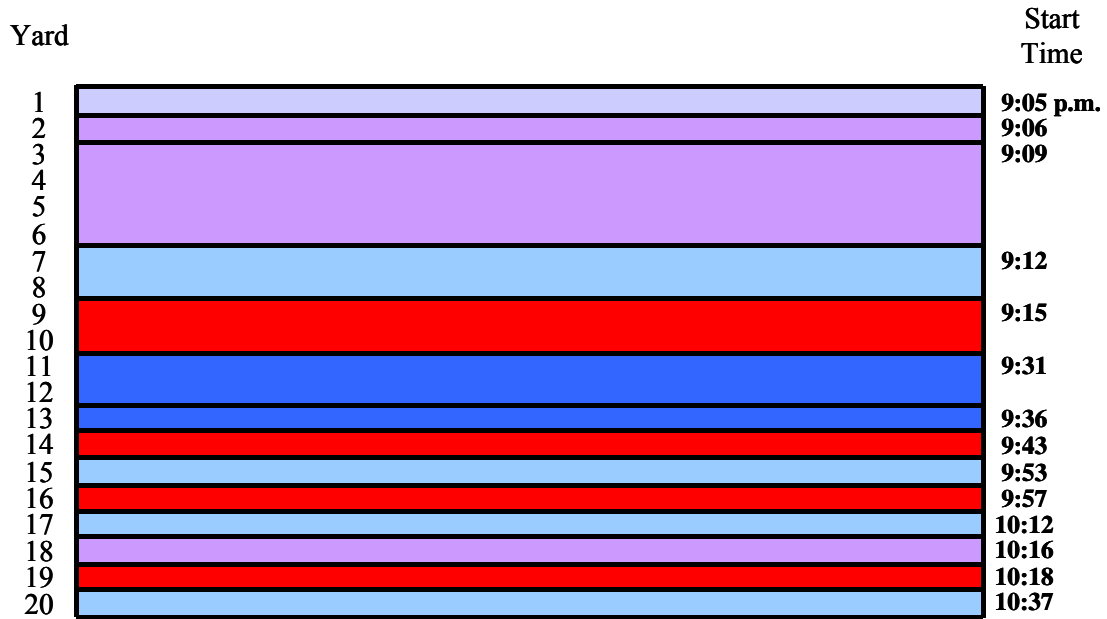


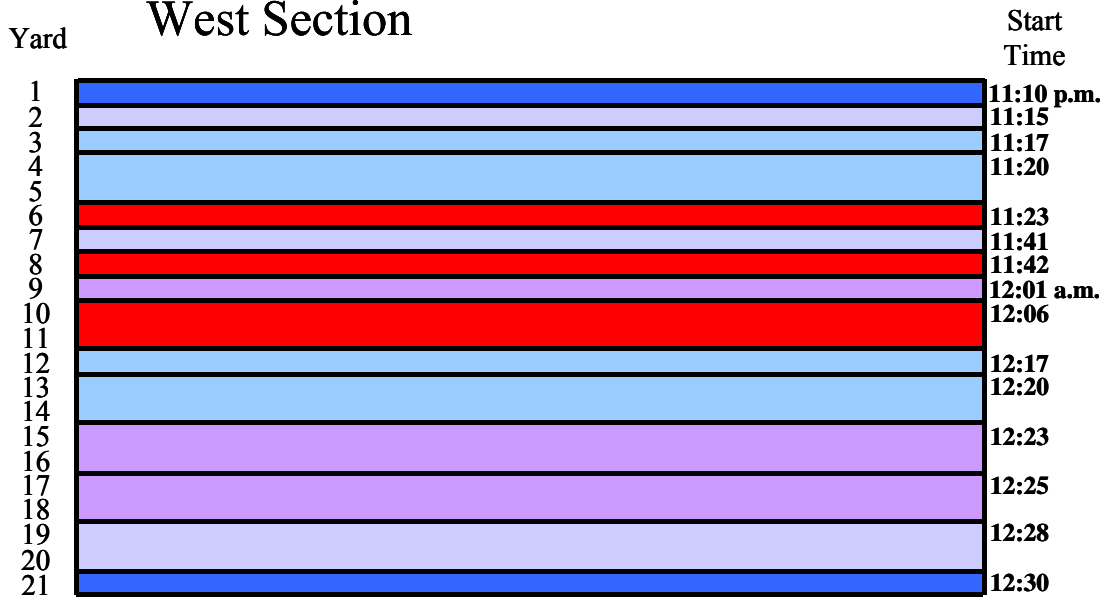
Figure 5-28. S26 of 50111, West section curing compound application time sequence

### **5.4.3 Bridge ID S05 of 82191**

Figure 5-29 shows the sequence of concrete placement for the monitored sections of the deck. Figure 5-30 and Figure 5-31 show the information for the west and east sections in a bar chart format, allowing one to clearly see where any delays occurred. Figure 5-32 demonstrates the relationship between cumulative volume of concrete placed and elapsed time, while Figure 5-33 shows the fluctuation in placement time of concrete as it arrives on the trucks. Figure 5-34, Figure 5-35, and Figure 5-36 show data for the finishing of concrete with regard to time elapsed and observed delays. Texturing data is presented in Figure 5-37, Figure 5-38, and Figure 5-39. Since curing compound was not applied until the project team left the site, information with regard to application of curing compound was not available for this project.



### West Section



### East Section

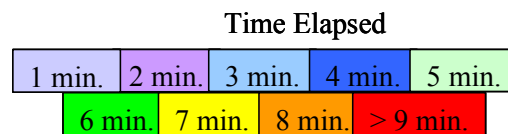


Figure 5-29. S05 of 82191, Concrete placement, time elapsed per yard

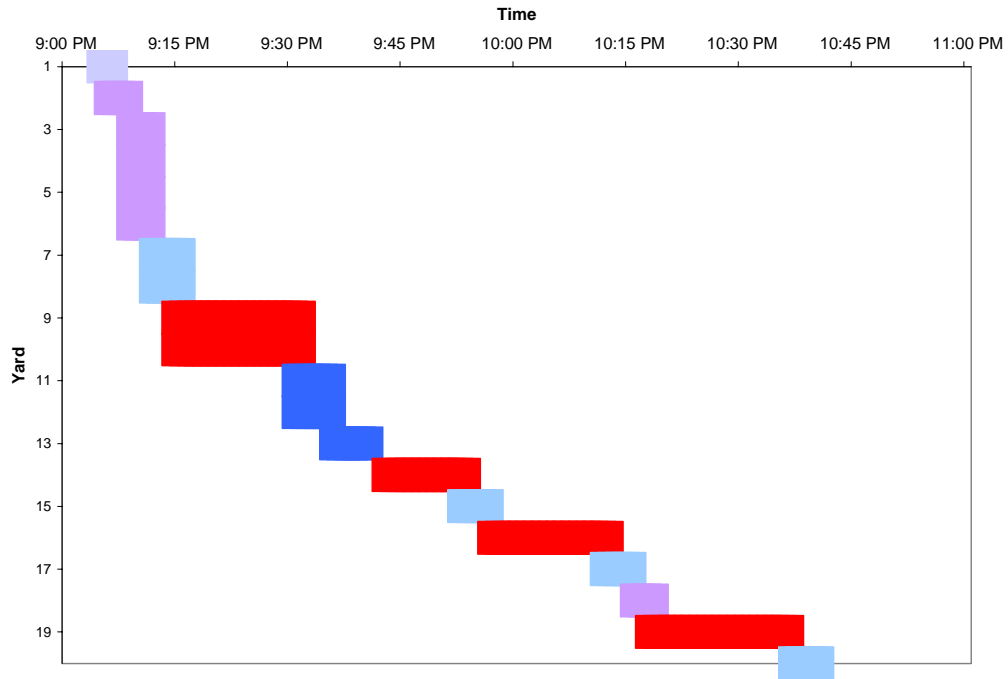


Figure 5-30. S05 of 82191, West section concrete placement time sequence

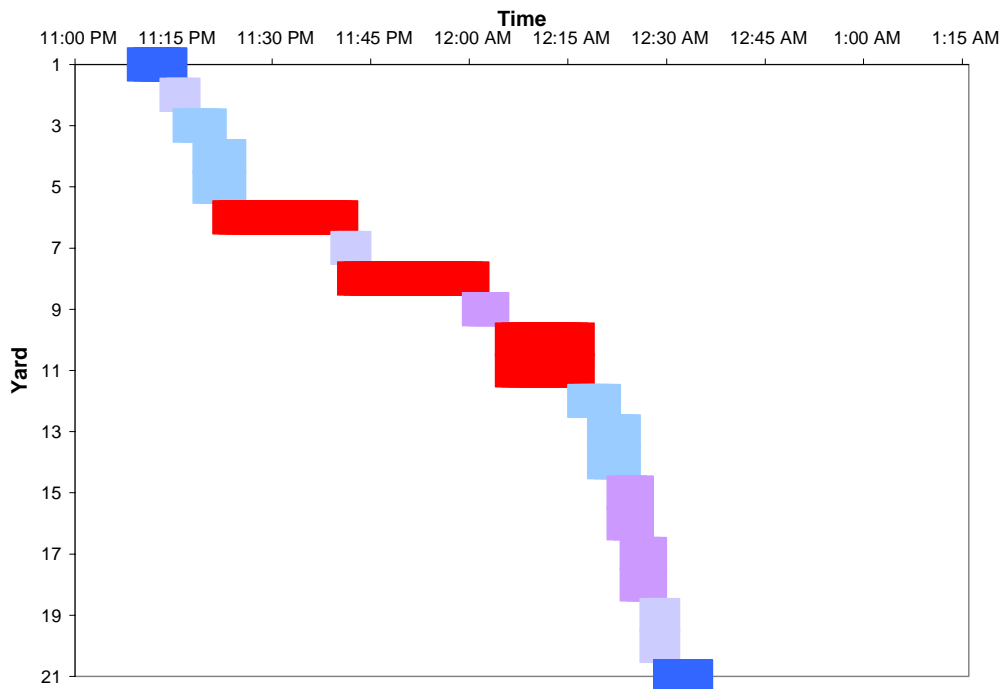


Figure 5-31. S05 of 82191, East section concrete placement time sequence

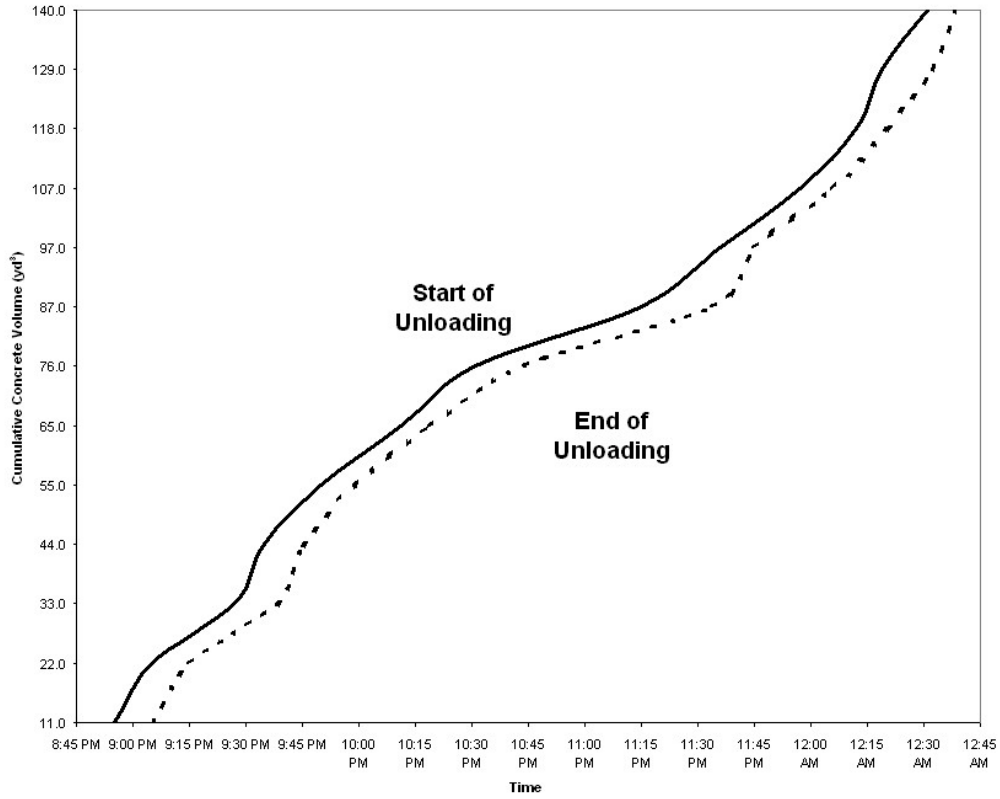


Figure 5-32. S05 of 82191, Cumulative concrete placed vs time elapsed

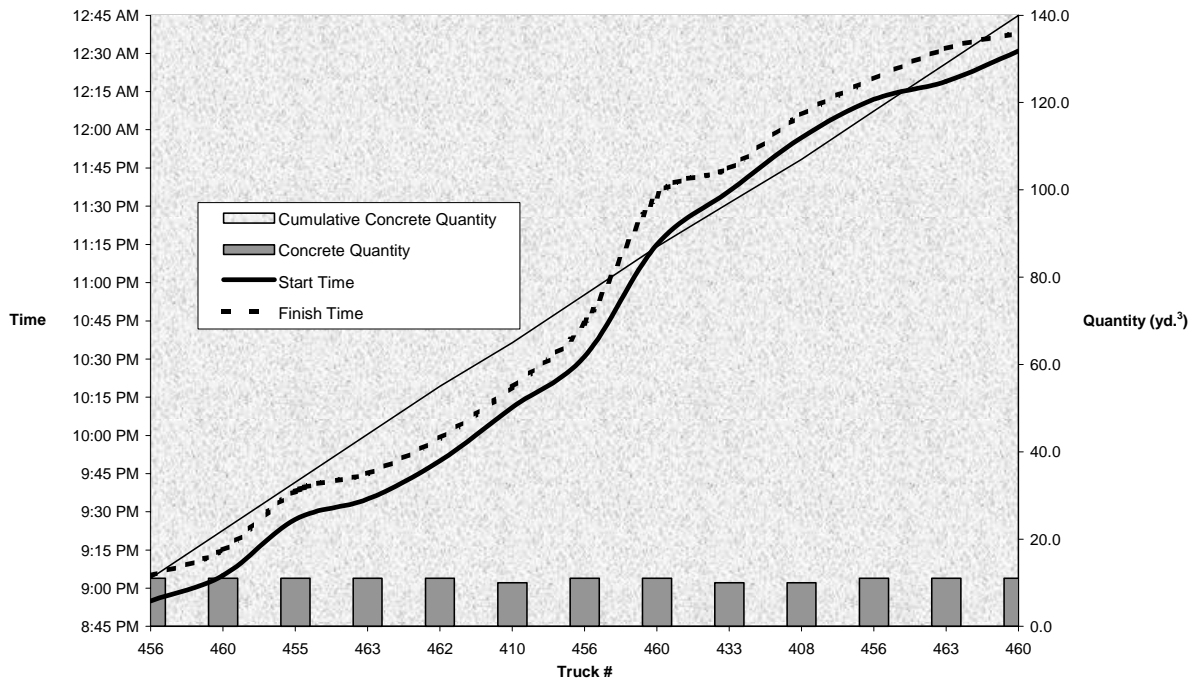


Figure 5-33. S05 of 82191, Time and volume of concrete placed vs truck arrival

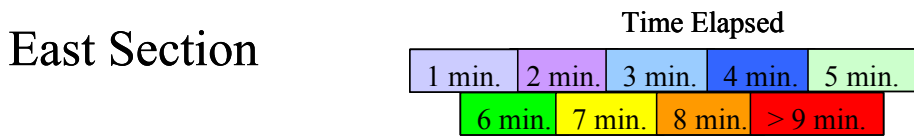
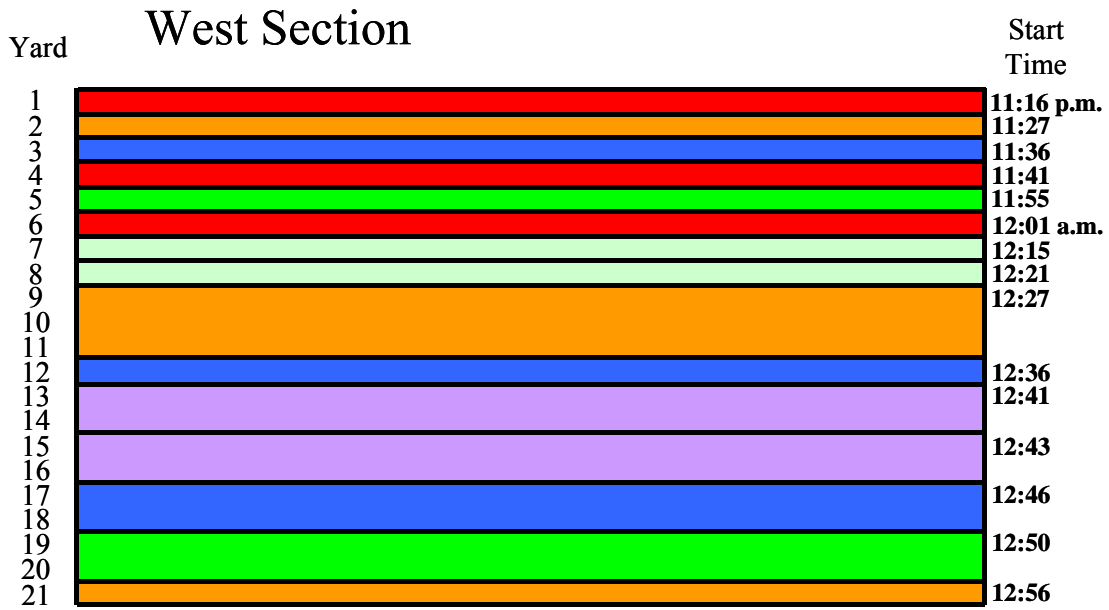
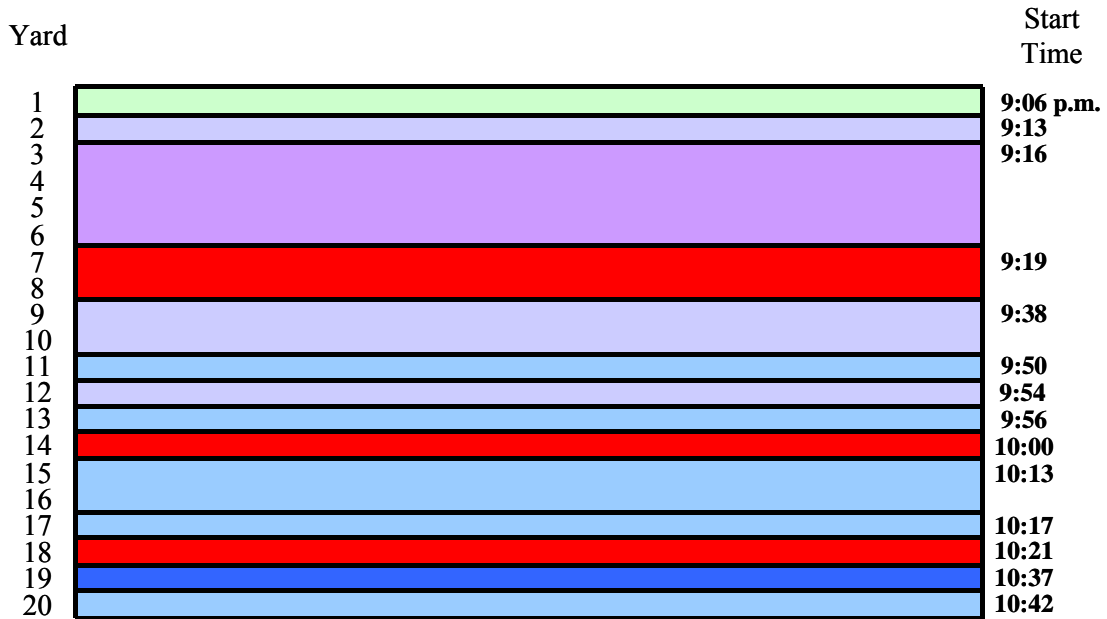
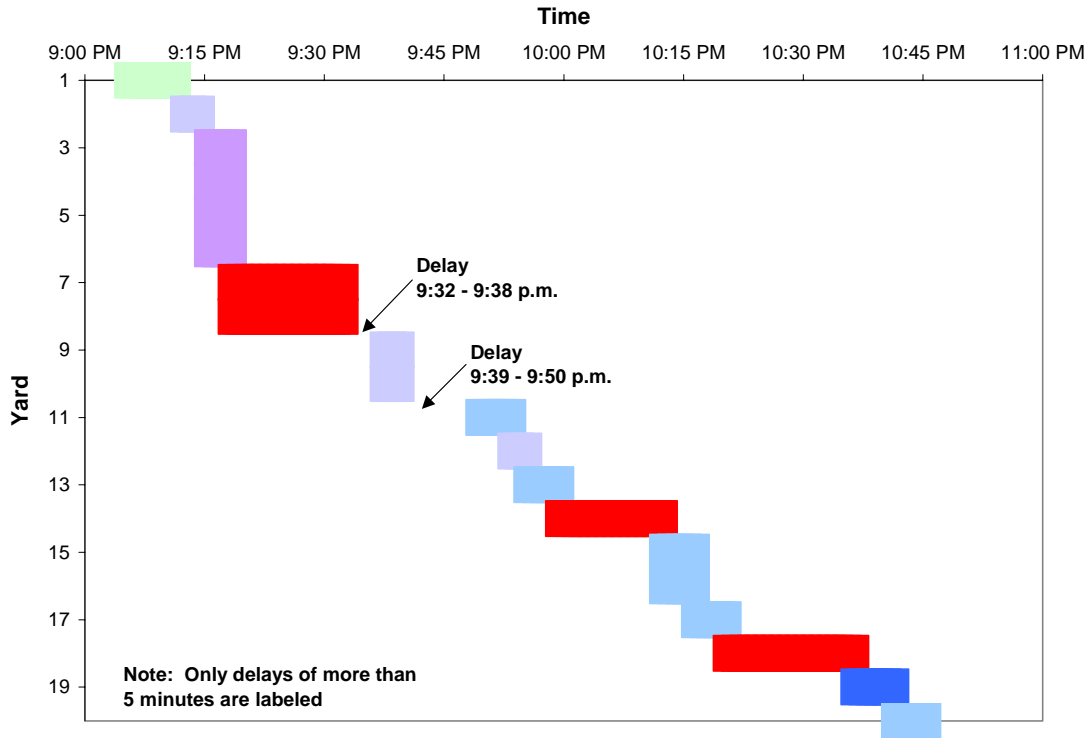
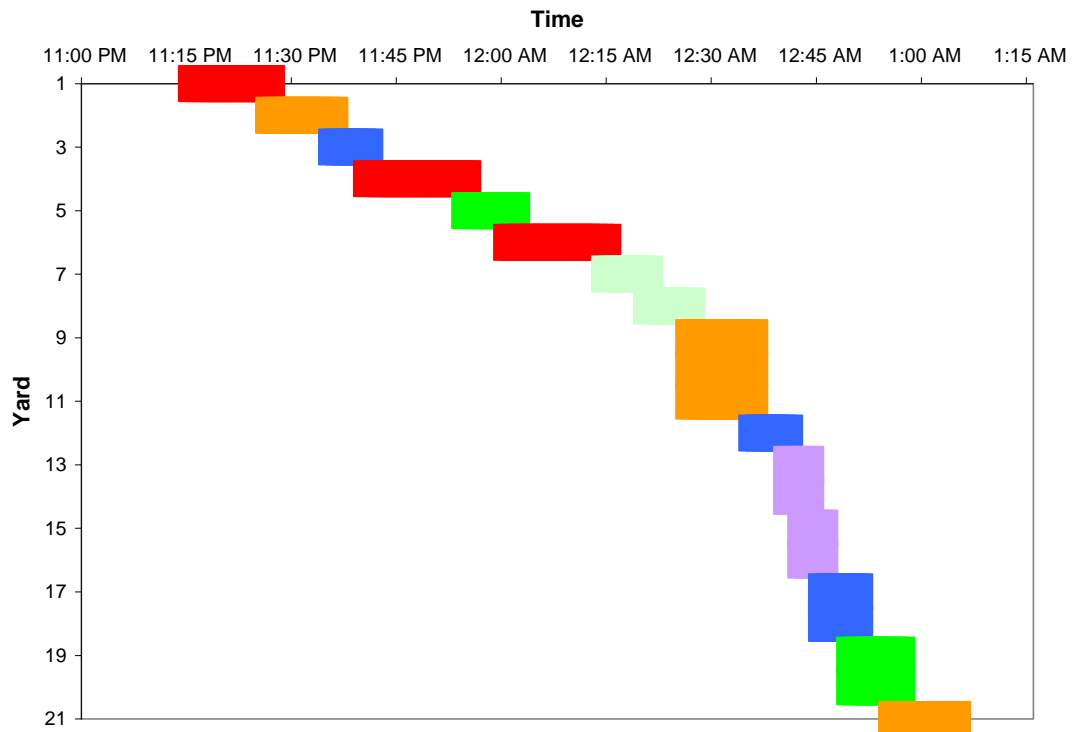


Figure 5-34. S05 of 82191, Concrete finishing, time elapsed per yard

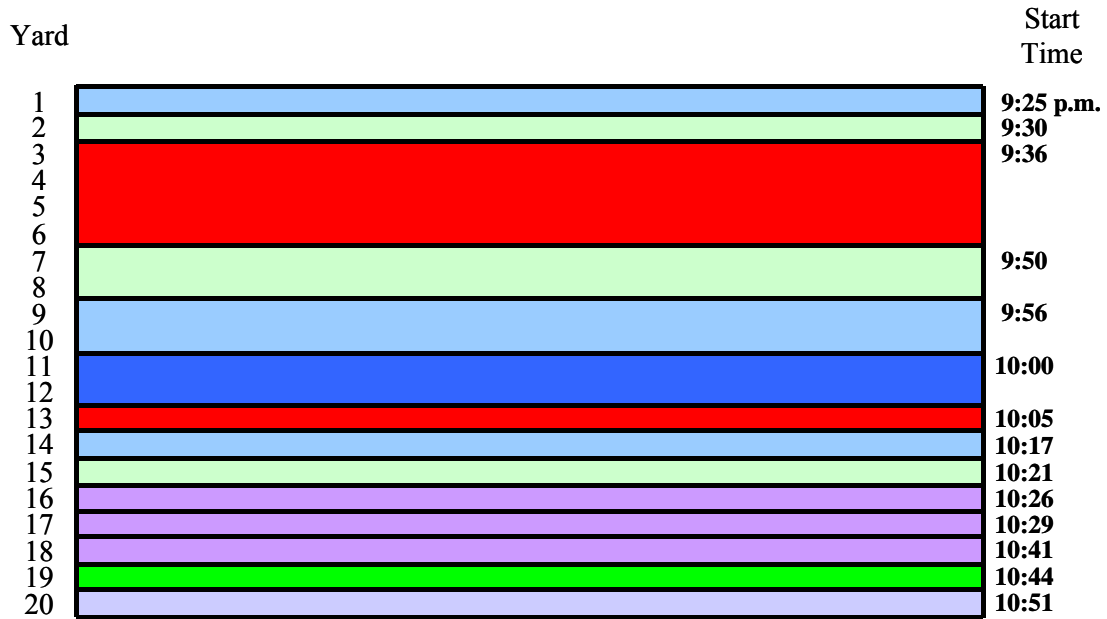


**Figure 5-35. S05 of 82191, West section concrete finishing time sequence**

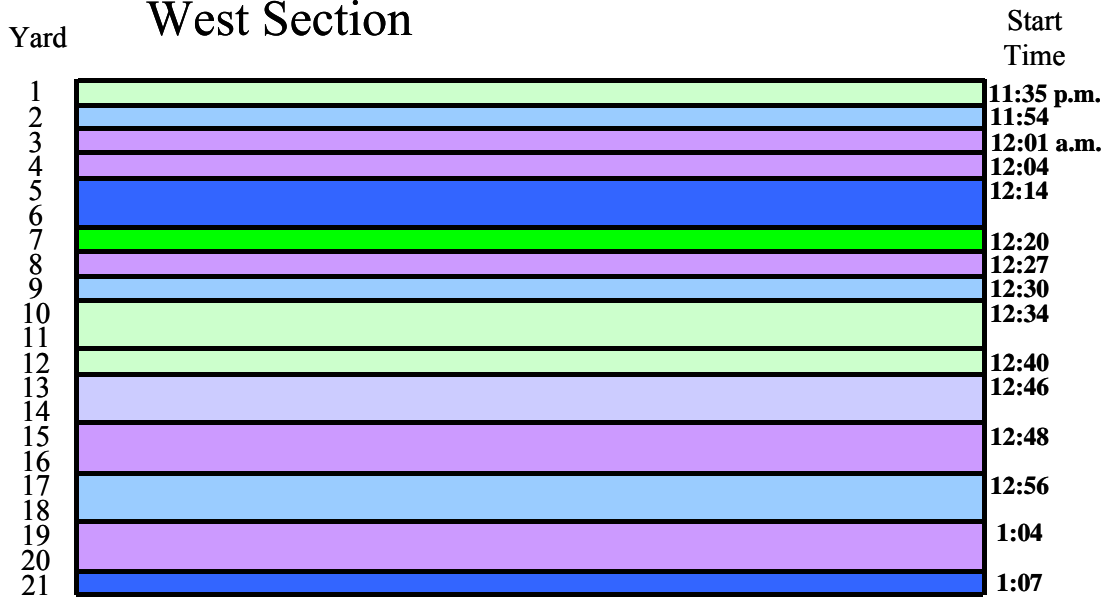


**Figure 5-36. S05 of 82191, East section concrete finishing time sequence**





### West Section



### East Section

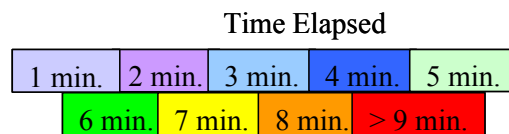


Figure 5-37. S05 of 82191, Concrete texturing, time elapsed per yard

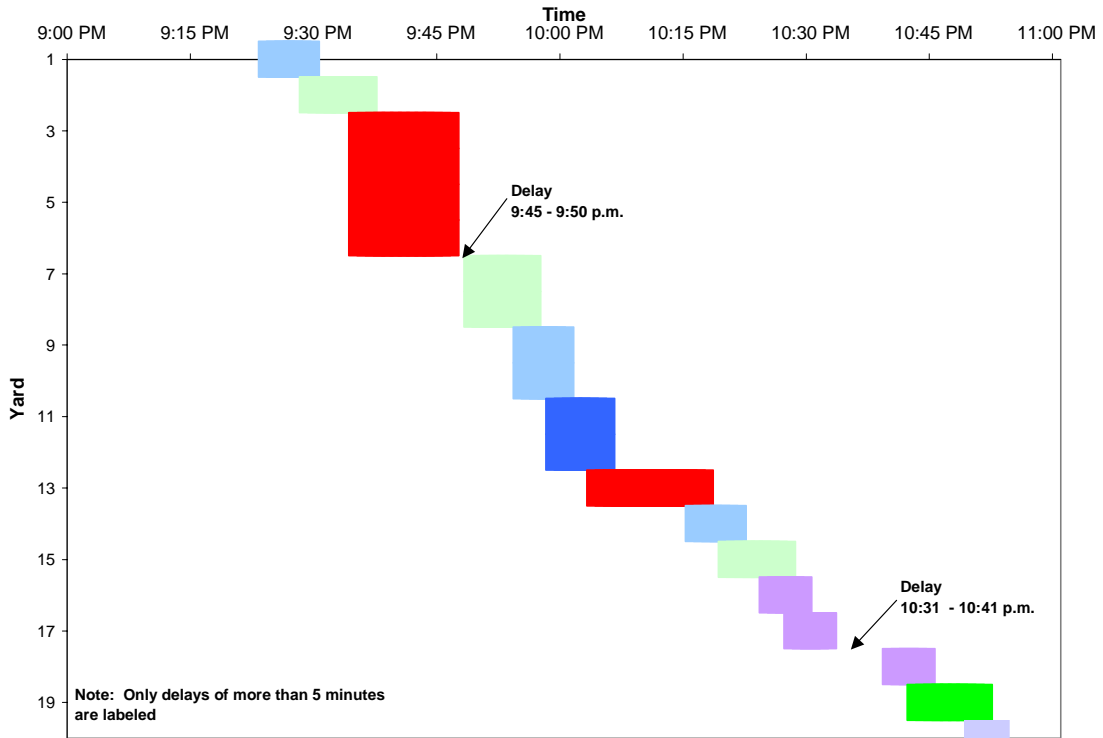


Figure 5-38. S06 of 82191, West section concrete texturing time sequence

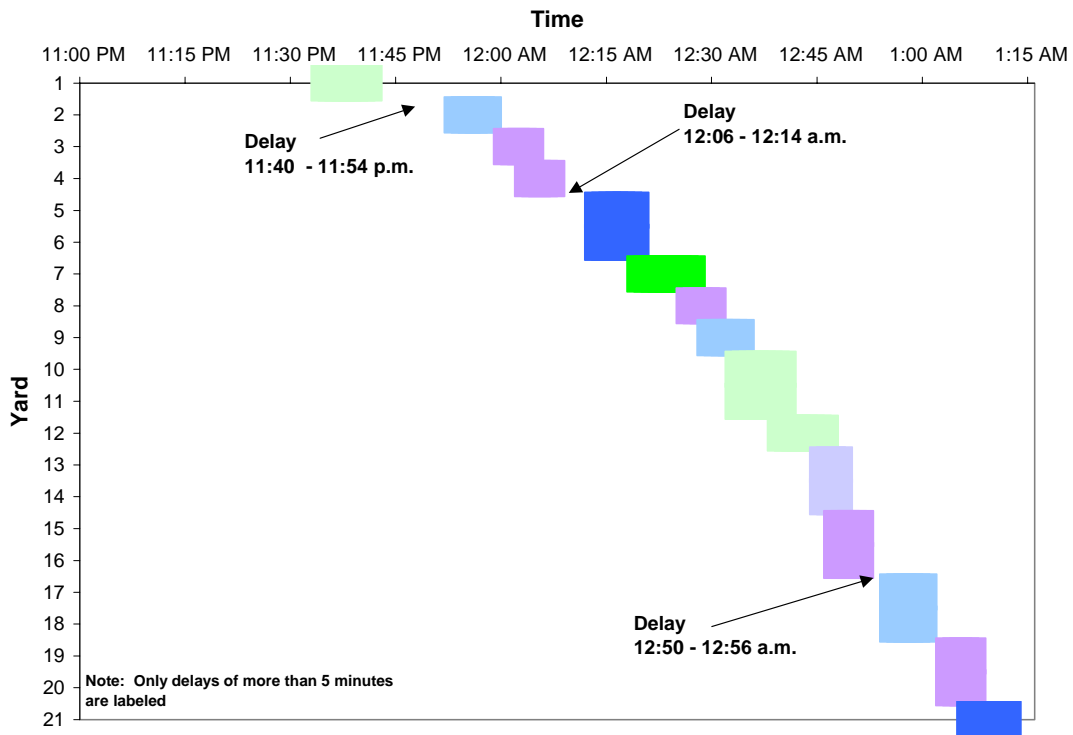
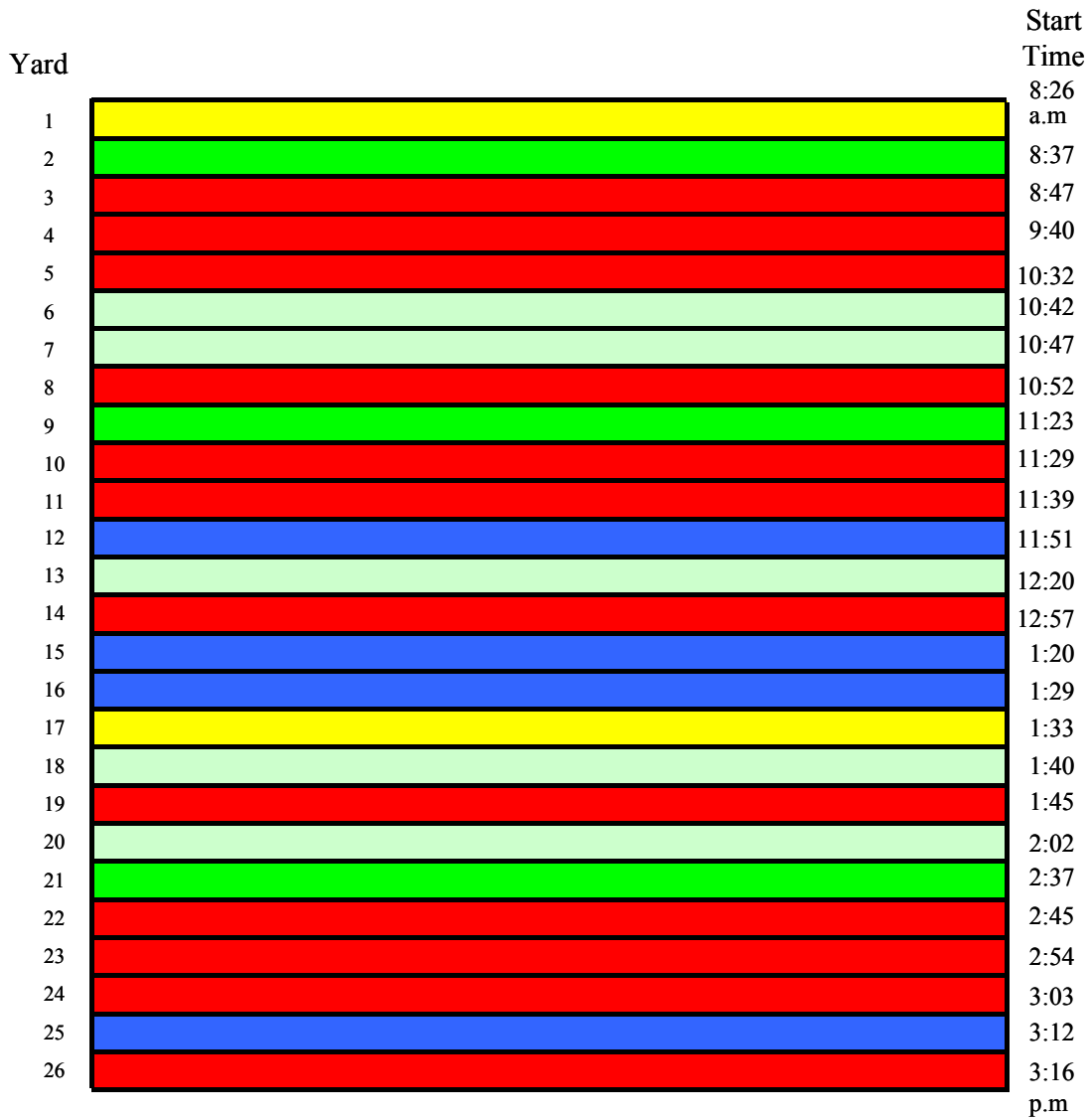


Figure 5-39. S05 of 82191, East section concrete texturing time sequence

#### **5.4.4 Bridge ID S05 of 82025**

Figure 5-40 shows the sequence of concrete placement for the monitored sections of the deck. Figure 5-41 shows the information for the section monitored in a bar chart format, allowing one to clearly see where any delays occurred. Figure 5-42 demonstrates the relationship between cumulative volume of concrete placed and elapsed time, while Figure 5-43 shows the fluctuation in placement time of concrete as it arrives on the trucks. Figure 5-44 and Figure 5-45 show data for the finishing of concrete with regard to time elapsed and observed delays. Texturing data is presented in Figure 5-46 and Figure 5-47. Information with regard to application of curing compound may be seen in Figure 5-48 and Figure 5-49.



**Time Elapsed**

1 min.	2 min.	3 min.	4 min.	5 min.
6 min.	7 min.	8 min.	> 9 min.	

**Figure 5-40. S05 of 82025, Concrete placement, time elapsed per yard**

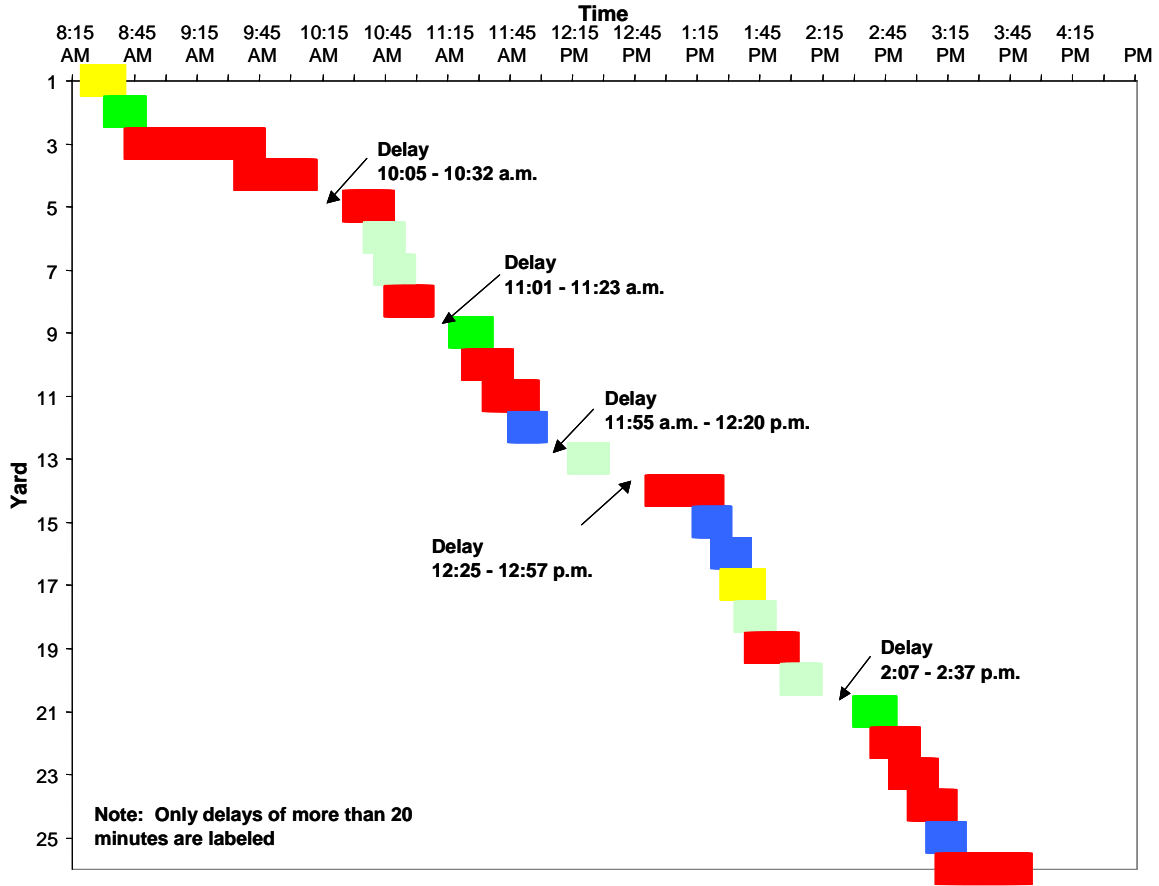


Figure 5-41. S05 of 82025, Concrete placement time sequence

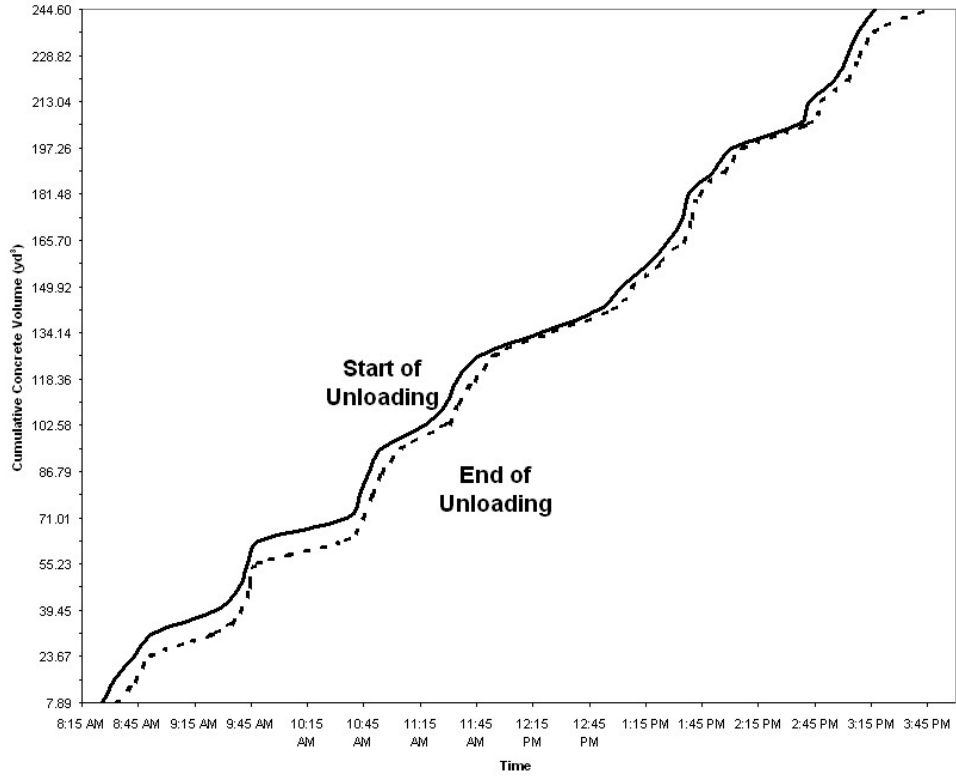


Figure 5-42. S05 of 82025, Cumulative concrete placed vs time elapsed

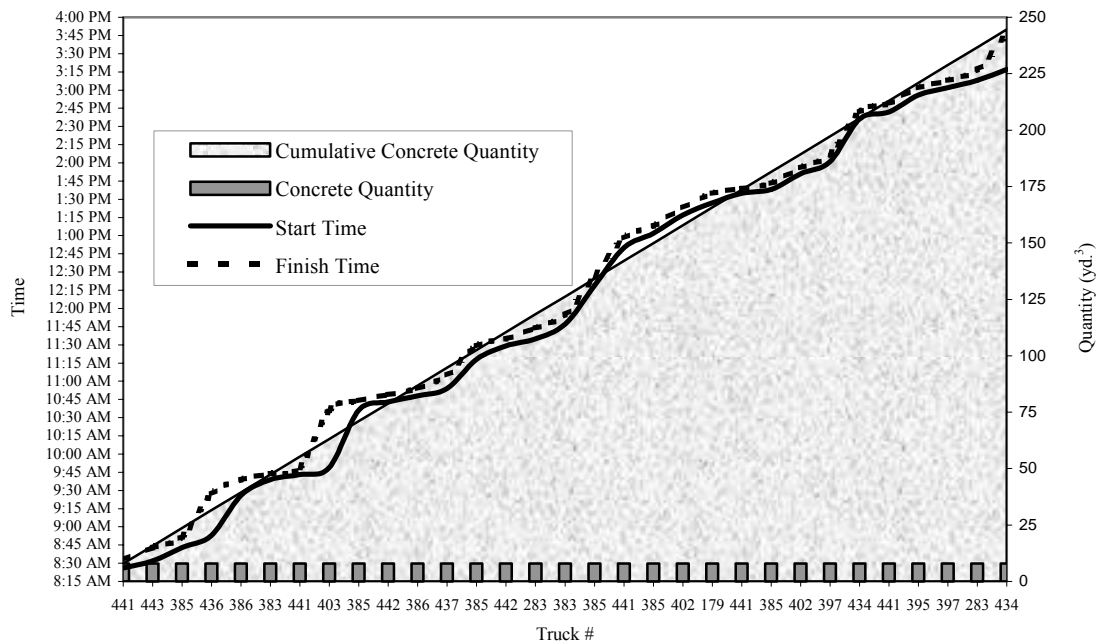
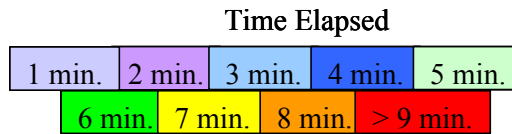
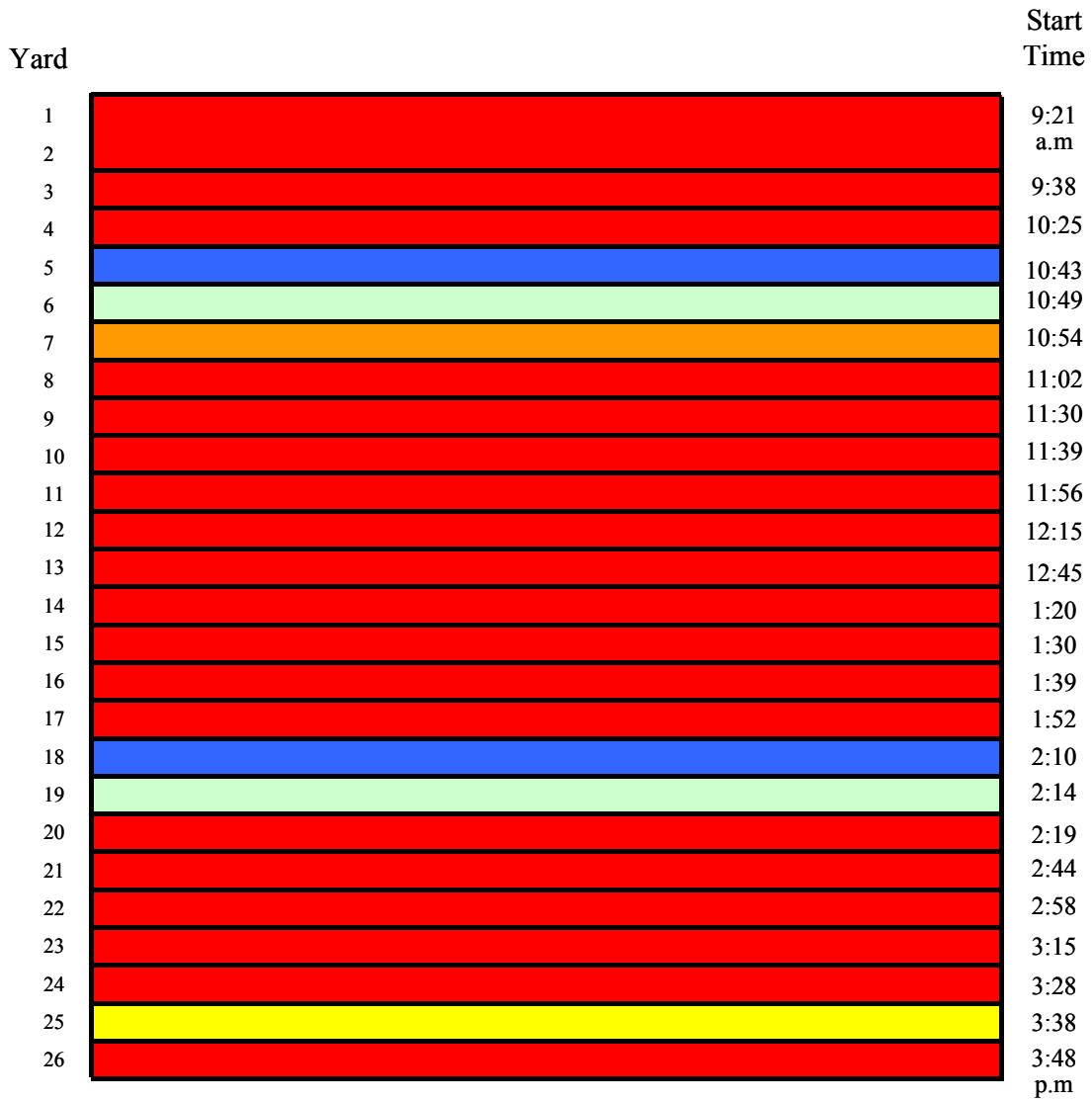


Figure 5-43. S05 of 82025, Time and volume of concrete placed vs truck arrival



**Figure 5-44. S05 of 82025, Concrete finishing, time elapsed per yard**

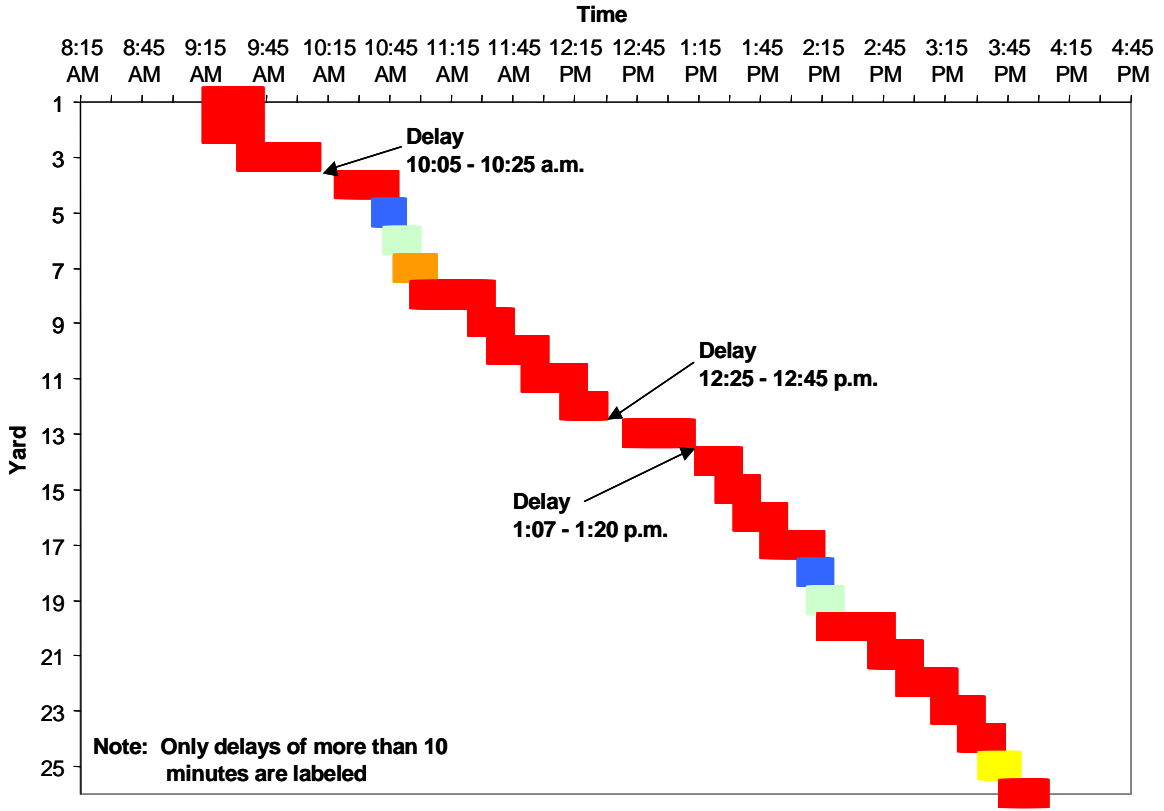
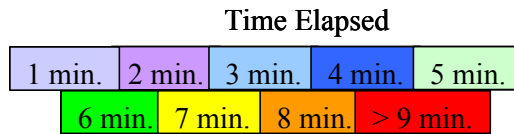
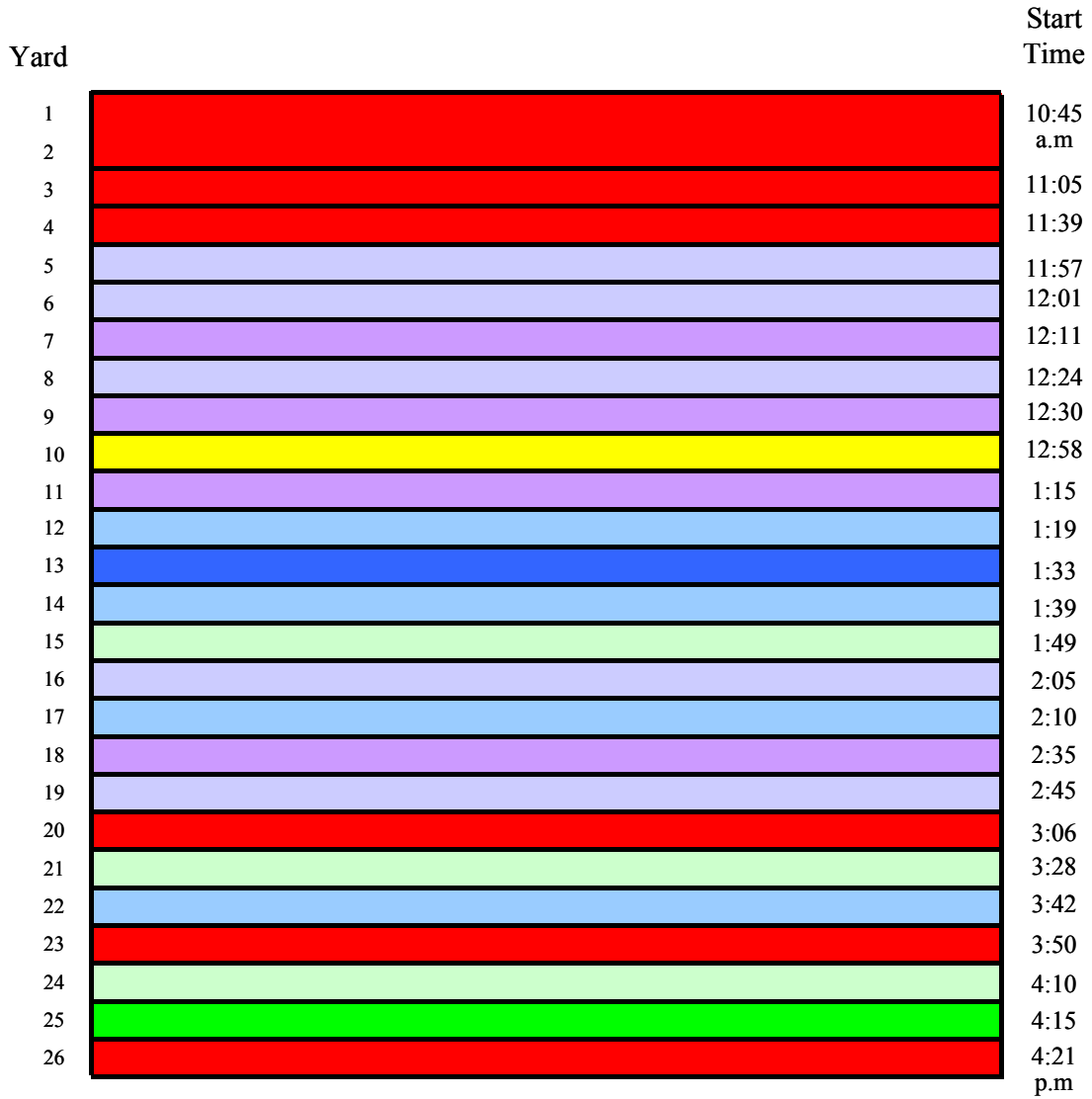


Figure 5-45. S05 of 82025, Concrete finishing time sequence





**Figure 5-46. S05 of 82025, Concrete texturing, time elapsed per yard**

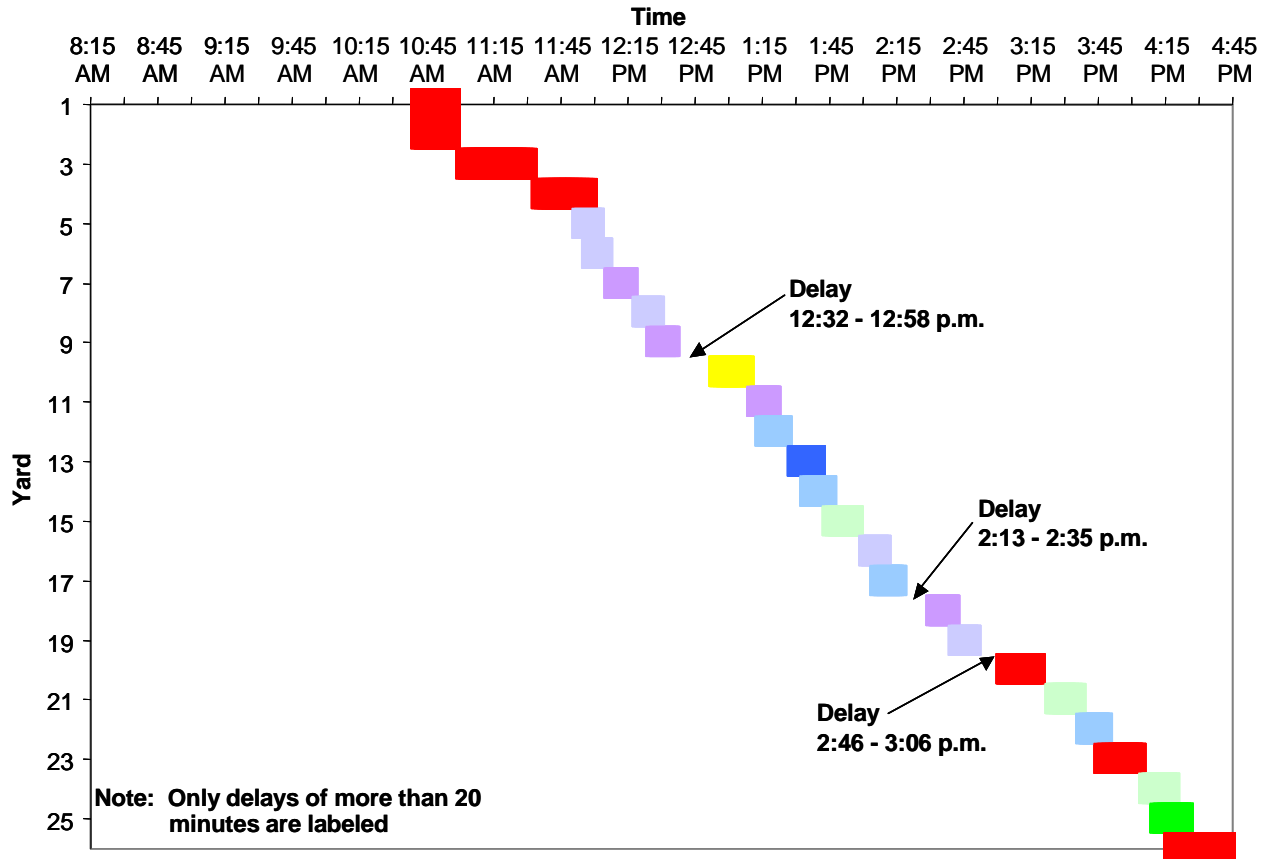


Figure 5-47. S05 of 82025, Concrete texturing time sequence

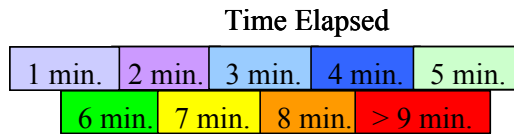
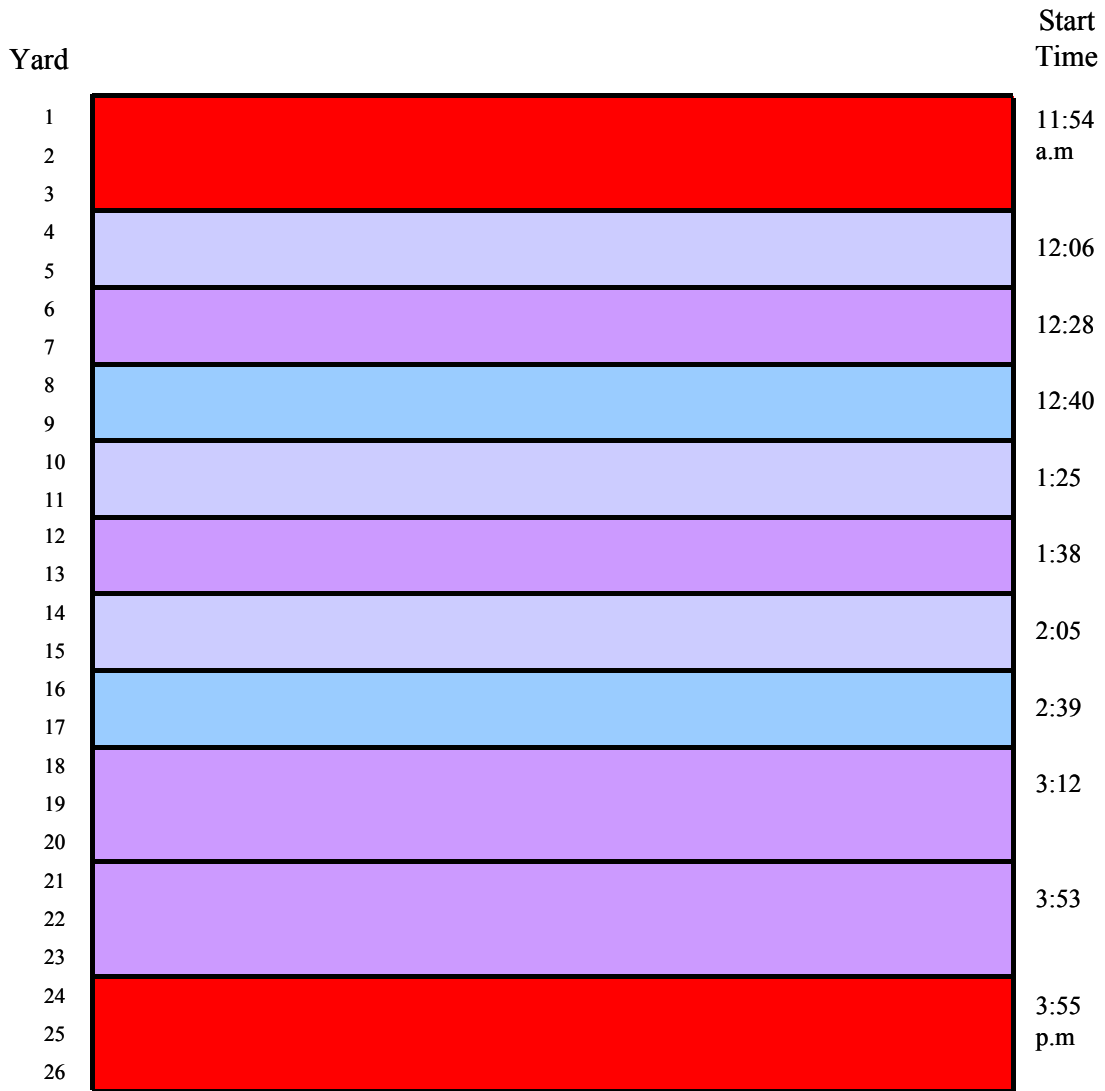


Figure 5-48. S05 of 82025, Curing compound application, time elapsed per yard

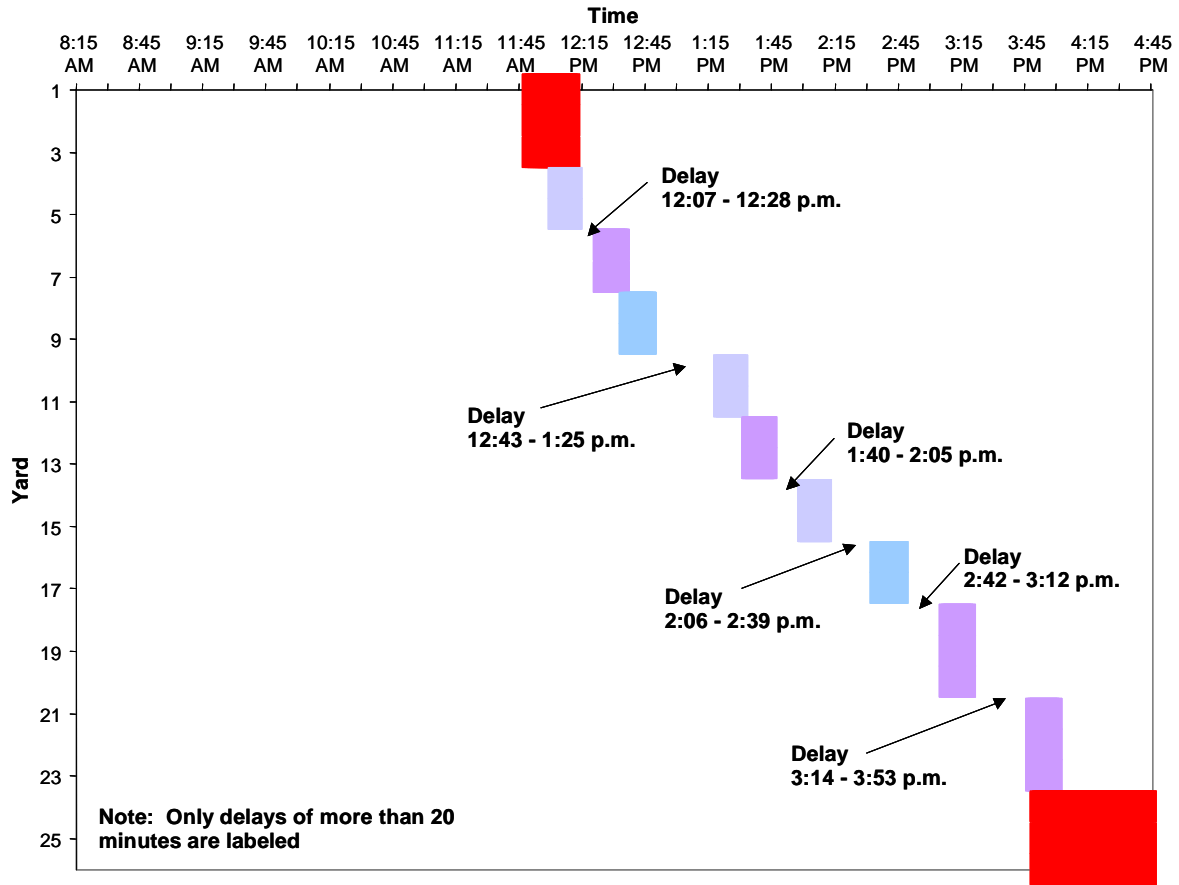


Figure 5-49. S05 of 82025, Curing compound application time sequence

### 5.4.5 Summary of Construction Monitoring Data

During construction monitoring, the purpose was to observe the procedures and the process timelines for concrete placement, texturing, and curing. The main focus was to identify the interruptions and delays that occurred during the process and their significance. As an example, the process timelines of concrete placement, texturing, and curing of bridge S05 of 82025 are depicted in Figure 5-50. Table 5-5, Table 5-6, Table 5-7, and Table 5-8 summarize the data gathered with regard to concrete placement, texturing, and curing compound application procedures for bridges S06 of 82194, S26 of 50111, S05 of 82191, and S05 of 82025 respectively. These tables provide data on start time and duration of each process, elapsed time between two consecutive processes, and the maximum delays that each process experienced. In the case of bridge S20 of 50111, the collected data was inconsistent and difficult to interpret; therefore, it was not included in the analysis.

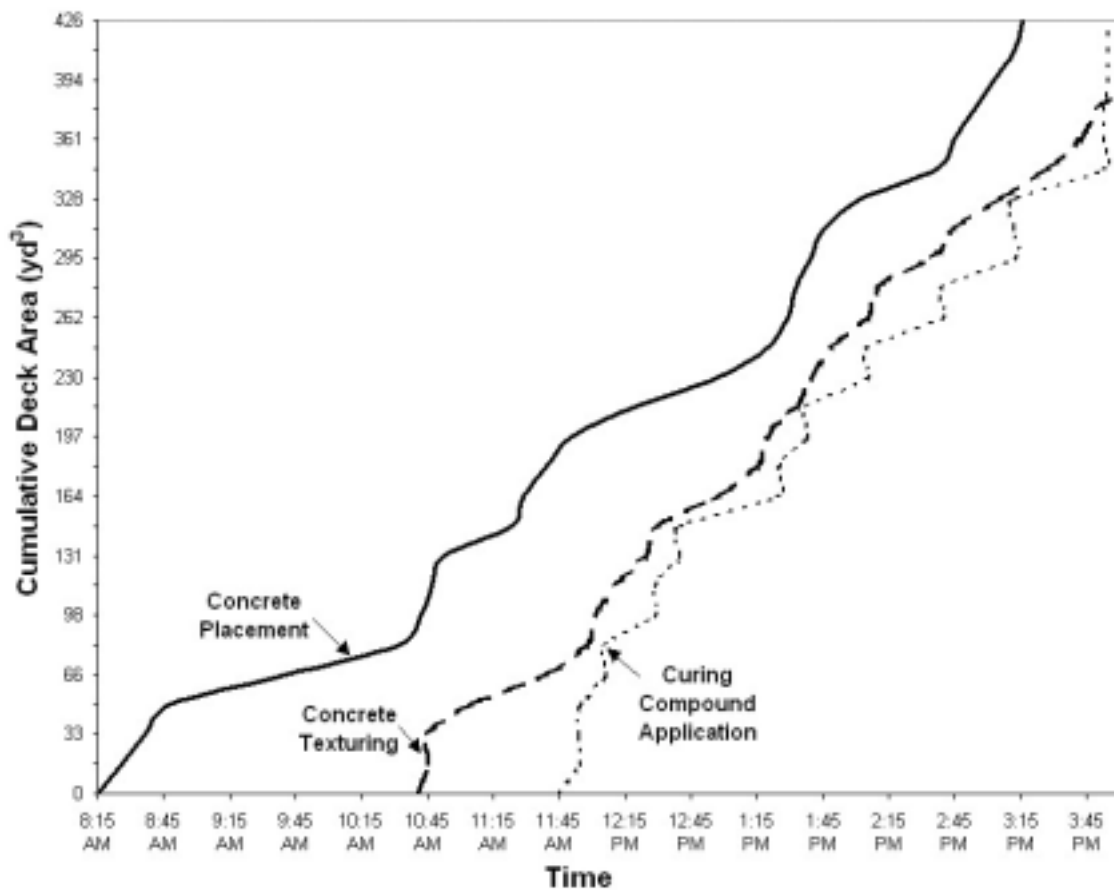


Figure 5-50. Summary of construction monitoring data of bridge S05 of 82025

**Table 5-5. Summary of Construction Monitoring Data for Bridge S06 of 82194**

Bridge ID		Section	Placement	Texturing	Curing
		S	Start Time	S	9:33 p.m.
N	9:48 p.m.			10:34 p.m.	
S06 of 82194	Duration (Hours)	S	1:57	2:57	0:45
		N	3:36	3:45	
S06 of 82194	Elapsed Time (Hours)	S	0:15		3:52
		N	0:46		
S06 of 82194	Max: Duration Interrupted (Hours)	S	0:18	0:39	0:17
		N	0:32	0:39	

**Table 5-6. Summary of Construction Monitoring Data for Bridge S26 of 50111**

Bridge ID		Section	Placement	Texturing	Curing
		E	Start Time	E	9:04 p.m.
W	11:30 p.m.			12:16 a.m.	12:29 a.m.
S26 of 50111	Duration (Hours)	E	1:56	2:33	2:30
		W	2:20	2:20	2:26
S26 of 50111	Elapsed Time (Hours)	E	0:38		0:13
		W	0:46		
S26 of 50111	Max: Duration Interrupted (Hours)	E	0:35	1:30	1:40
		W	0:00	0:14	0:38

**Table 5-7. Summary of Construction Monitoring Data for Bridge S05 of 82191**

Bridge ID		Section	Placement	Texturing	Curing
		S05 of 82191	Start Time	W	9:05 p.m.
E	11:10 p.m.			11:35 p.m.	
Duration (Hours)	W		1:32	1:26	
	E		1:20	1:32	
Elapsed Time (Hours)	W		0:20		
	E		0:25		
Max: Duration Interrupted (Hours)	W		0:00	0:10	
	E		0:00	0:14	

**Table 5-8. Summary of Construction Monitoring Data for Bridge S05 of 82025**

Bridge ID		Placement	Texturing	Curing
		S05 of 82025	Start Time	8:26 a.m.
Duration (Hours)	6:50		5:36	4:01
Elapsed Time (Hours)	2:19		1:09	
Max: Duration Interrupted (Hours)	0:32		0:26	0:42

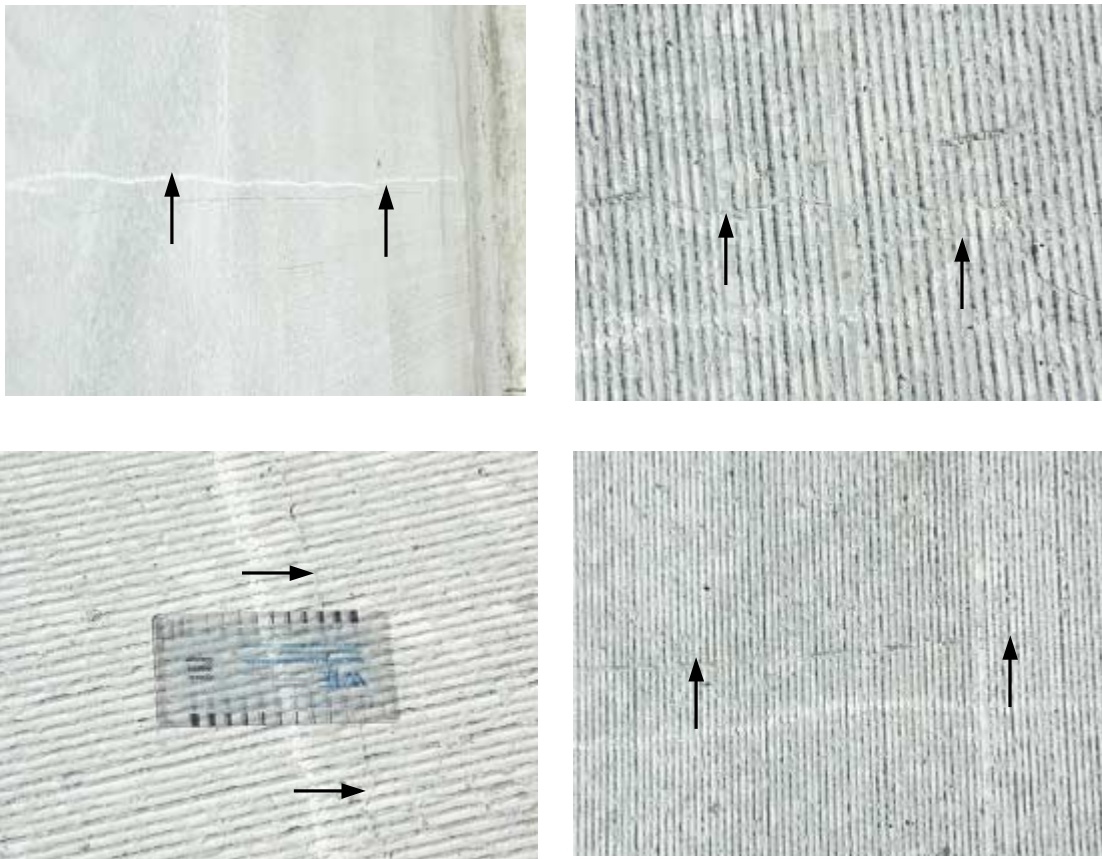
## 5.5 POST-CONSTRUCTION MONITORING OF BRIDGE DECKS

Photo 5-10 shows the replaced deck of the bridge S06 of 82194. This bridge deck replacement started on 8/19/2002, this was a two-day process. Inspection for early-age cracking was performed on 9/13/2002. The diamond ground deck surface was helpful when observing the early-age cracks. During the observations, several transverse cracks were identified (Photo 5-11). Several transverse cracks were also seen on the deck of bridge S05 of 82025 during post-construction inspection. Unfortunately, photographs are not available.



**Photo 5-10. Replaced deck of bridge S06 of 82194**





\* Crack locations are shown with arrows

**Photo 5-11. Observed cracking on replaced deck of bridge S06 of 82194**

## 5.6 CONCLUSIONS

Five bridge reconstruction projects with deck replacements were selected with consideration to the construction dates. Construction monitoring of five bridges was completed including one late season deck replacement. During concrete placement, ambient temperature and ambient moisture conditions were recorded. Truck number, production time, truck arrival time, and unloading (start/finish) time were also recorded. Finally, starting and finishing time for concrete placement, finishing, texturing, and curing for the areas within an approximate one-yard width were monitored and recorded.

The requirements for the formwork, placement of steel reinforcements, placement of concrete, finishing of plastic concrete, and curing given in MDOT Section 706 of Standard Specifications for Construction were compared with the field observations.

The reinforcement as well as the interior of the formwork was cleaned before placement of concrete. The concrete crew made an effort to place the concrete uniformly and in its final position. Shovels were sometimes used to spread concrete from one location to another. It was hard to control the free-fall to within the required limit of 6 inches. Most often, free fall was about one foot. In certain instances, it was between two and three feet.

Additionally, concrete placement was sometimes interrupted due to delays in its delivery to the job site. The time data collected at the site during deck placement show that the delay sometimes exceeded 30 minutes. Consequently, the requirements in the Specifications stating that “sufficient vibrators shall be used to properly compact the incoming concrete within 15 minutes after placing” could not be satisfied. When the new concrete arrived and was placed on the deck, the old and the new portions were then consolidated together. In addition, the vibrator applications were random rather than following a distinct pattern as required in the Specifications.

Section 706.03 N of Standard Specifications for Construction describes the curing procedure for concrete bridge decks. When curing is considered, most of the Specification requirements were not met for the five projects that were monitored. One of the requirements in the Specifications is that more than 10 feet of textured concrete surface should not be left exposed without curing compound at any time. As reported earlier, this requirement was never satisfied. Out of five instances of construction monitoring, one time, a curing compound was applied after completing the placement of concrete on the full deck and in another instance, curing compound was not applied until sometime after the project team left the site, which was after the casting crew finished concrete placement, leveling, and texturing. Wet curing is another important requirement given in the Specifications. It requires covering the concrete with clean, contaminate-free wet burlap as soon as the curing compound has dried sufficiently to prevent adhesion and the concrete surface can support it without deformation. However, wet burlap should have been applied within two hours after the concrete was cast. Based on the observations, it can be concluded that the concrete surface was never covered with burlap until the next day.

Heavy equipment, such as mixers and slip form machines, are not be permitted on the deck until the deck concrete has reached an age of at least 7 days and then not until the concrete has attained at least 100 percent of its minimum 28 day flexural or compressive strength. However, barrier casting started on some bridges when the bridge decks were seven days old. Therefore, mixers, slip-form machines, and several other vehicles traveled and parked on the newly placed bridge decks.

It was observed that on one deck with super elevation (S06 of 82194), fresh concrete did not have sufficient stiffness and therefore flowed to one side. The deck surface needed to be diamond ground in order to achieve appropriate leveling. In all of the bridge decks, the construction or expansion joint boundaries were observed to be quite problematic during placement. Excess concrete overflows, loses its plasticity and it is scraped off and thrown in with the deck concrete near the joint. This creates a substandard quality concrete near the joint. Deterioration often starts at the joints. During placement, the concrete that falls off the joints should not be placed back on the deck.

In two decks (S20 of 50111 and S05 of 82025), the specimens prepared for the laboratory testing were not fully set at approximately 12 hours after placement. Although the concrete mix design did not show increased use of set-retarders, these observations show otherwise.

## 6 FIELD AND LABORATORY TESTING

### 6.1 OVERVIEW

Determination of mechanical and other important physical properties related to concrete durability may be accomplished through several standard tests. Mechanical properties of deck concrete are obtained from compressive strength and elasticity modulus tests in accordance with ASTM C39 and ASTM C 469 respectively. The compressive strength test is the most common test performed on hardened concrete. There is a strong correlation between the properties of concrete and its compressive strength. This test was used to evaluate the performance of the materials and can help establish the necessary mixture proportion to attain the required strength. An additional advantage of this test is its ability to control the quality of the concrete in the field.

Elasticity modulus and Poisson's ratio tests provide a value for stress to strain ratio and a ratio of lateral to longitudinal strain for hardened concrete at any designated curing age. The modulus of elasticity and Poisson's ratio values are applicable in stress ranges from 0 to 40% of the ultimate concrete strength. This method is helpful in sizing of reinforced and non-reinforced structural members, establishing the quantity of reinforcement, and computing the stress from intrinsic strains. In addition, by conducting compressive strength, elasticity modulus, and Poisson's ratio tests at different ages of concrete, the variation of mechanical properties with respect to time is established and may be used for further analysis of causes of distress.

The ultrasonic pulse velocity (UPV) test measures the velocity of an ultrasonic wave passing through the concrete. The pulse velocity of compressive waves in concrete is related to its elastic properties and density. This test method is used to evaluate the uniformity and relative quality of concrete, to indicate the presence of voids and cracks, to estimate the depth of cracks, and to evaluate the effectiveness of crack repairs. It may also be used to identify changes in the properties of concrete, and in the survey of structures, to estimate the severity of deterioration of cracking. From ultrasonic pulse velocity, dynamic elasticity modulus can be calculated. This test is performed in compliance with ASTM C597.

The rapid chloride permeability test (RCPT) is performed in accordance with ASTM C 1202. This test is useful in determining the electrical conductance of concrete and provides an

indication of its resistance to penetration of chloride ions. The absorption and air permeability tests are useful in developing the data required for the calculation of void ratio and to obtain the limits of absorption. Concrete with large or many pores is not desirable due to its lack of ability to protect itself from environmental attacks (i.e. chloride ion penetration); therefore, it is ideal to obtain a low pore-volume ratio for quality concrete. The absorption test is performed in compliance with ASTM C642. The air-permeability test is performed using a special apparatus not yet specified by ASTM.

### 6.1.1 Samples Obtained During Construction Monitoring

A comprehensive list, which enumerates the tests performed on the cylinder specimens and the required number of samples for the tests, is given in Table 6-1. Compressive strength, elasticity modulus, Poisson’s ratio, rapid chloride permeability test (RCPT), ultrasonic pulse velocity (UPV), air-permeability, and absorption tests were conducted and the test results are shown in Table 6-3, 6-4, 6-5, 6-6, 6-7, 6-8, and 6-9 respectively.

**Table 6-1. Tests to be Conducted and the Required Number of Samples**

Tests	Type of Specimen	Number of Specimens	Test Days					Total Number of Specimens
			3	7	28	56	90	
<b>Compressive Strength</b> (ASTM – C 39)	6 x 12 in	4	x	x	x	x	x	20
<b>Modulus of Elasticity</b> (ASTM – C 469)	6 x 12 in	2	x	x	x	x	x	10
<b>UPV</b> (ASTM – C 597)	4 x 8 in	12	x	x	x	x	x	12
<b>Permeability</b>	4 x 2 in	4			x	x	x	12
<b>RCPT</b> (ASTM – C 1202)	4 x 2 in	4			x	x	x	
<b>Absorption</b> (ASTM – C 642)	4 x 2 in	4			x	x	x	

### **6.1.2 Test Procedures for Samples Obtained During Construction Monitoring**

During the placement of concrete bridge decks, a number of cylindrical test specimens (minimum thirty-two 6-in.x12-in. and twenty four 4-in.x 8-in.) were prepared for laboratory testing according to Table 6-1. The specimens were kept in the field for one day. After twenty-four hours, specimens were taken to the laboratory. Specimens were cataloged according to their size and wet cured for 28 days. After the 28 days of initial curing, the specimens were kept under ambient laboratory air. Compressive strength, modulus of elasticity, Poisson's ratio, and ultrasonic pulse velocity tests were conducted at the ages of 3, 7, 28, 56, and 90 days. Rapid chloride permeability (RCPT), absorption, and air-permeability tests were conducted at the ages of 28, 56, and 90 days. The test schedule and the laboratory data sheets are presented in Appendix D and Appendix E respectively.

### **6.1.3 Test Procedure for Fresh Concrete Properties**

Standard field tests are conducted on freshly mixed concrete to ensure that the material is properly constituted to meet the requirements of a particular construction task. For most construction projects involving the use of concrete, these field tests are the quickest and most cost effective way to make certain that the composition of the concrete used is right for the job. The tests conducted are the C143-Slump of Portland Cement Concrete, C231-Air Content of Freshly Mixed Concrete (Pressure Method), and C1064-Temperature of Freshly Mixed Portland Cement Concrete.

## 6.2 TEST RESULTS

### 6.2.1 Fresh Concrete Properties

Table 6-2. Field Tests for Quality Control of Fresh Concrete

Bridge ID	Slump (inches)	Air Content (%)	Concrete Temperature (°F)
S05 of 82191	7	7	89
S06 of 82194	5	6.5	78
S26 of 50111	5	7.4	75
S20 of 50111	5	7.2	78
S05 of 82025	4	6.2	60

### 6.2.2 Construction Monitoring Samples

Tables 6-3, 6-4, and 6-5 show mean values and coefficient of variance for compressive strength, elasticity modulus, and Poisson's ratio respectively. Rapid Chloride Permeability Test (RCPT), Ultrasonic Pulse Velocity (UPV), air permeability, and absorption test results are given in Tables 6-6, 6-7, 6-8, and 6-9 respectively.

All the tests were conducted according to ASTM Standards and the respective Standards are given in Table 6-1. Air permeability tests were performed at University of Windsor.

**Table 6-3. Compressive Strength Test Results**

Bridge ID	Compressive Strength (psi)									
	f'c,3	COV (%)	f'c,7	COV (%)	f'c,28	COV (%)	f'c,56	COV (%)	f'c,90	COV (%)
<b>S05 of 82191</b>	3580	5.2	4248	5.0	5098	6.4	5913	2.4	6090	3.2
<b>S06 of 82194</b>	3748	3.2	4455	2.2	5067	4.9	-	-	6245	4.0
<b>S26 of 50111</b>	4710	3.4	5353	4.0	-	-	7098	2.0	7283	3.3
<b>S20 of 50111</b>	4708	1.9	5550	4.0	-	-	7490	1.4	7417	1.4
<b>S05 of 82025</b>	5090	0.7	5650	2.3	6770	2.8	7628	1.9	7848	2.2

- Missing data

**Table 6-4. Modulus of Elasticity Test Results**

Bridge ID	Modulus of Elasticity (ksi)									
	E,3	COV (%)	E,7	COV (%)	E,28	COV (%)	E,56	COV (%)	E,90	COV (%)
<b>S05 of 82191</b>	4519	-*	4818	-*	5216	-**	5392	2.9	5050	2.4
<b>S06 of 82194</b>	4761	-*	4654	-*	5402	1.7	-	-	4986	4.0
<b>S26 of 50111</b>	4195	-*	4515	-*	-	-	4225	2.0	3953	1.4
<b>S20 of 50111</b>	4412	-*	4627	-*	-	-	4432	0.6	4081	2.4
<b>S05 of 82025</b>	5424	-*	5386	-*	5877	2.9	5665	0.8	5630	0.9

- Missing data

-\* - Only two readings are available

-\*\* - Only three readings are available



**Table 6-5. Poisson's Ratio Test Results**

Bridge ID	Poisson's Ratio									
	$v_{,3}$	COV (%)	$v_{,7}$	COV (%)	$v_{,28}$	COV (%)	$v_{,56}$	COV (%)	$v_{,90}$	COV (%)
<b>S05 of 82191</b>	0.23	-*	0.24	-*	0.26	-**	0.24	2.4	0.25	5.4
<b>S06 of 82194</b>	0.25	-*	0.22	-*	0.25	2.5	-	-	0.25	3.8
<b>S26 of 50111</b>	0.25	-*	0.24	-*	-	-	0.24	4.7	0.21	0.2
<b>S20 of 50111</b>	0.25	-*	0.25	-*	-	-	0.23	1.2	0.23	4.9
<b>S05 of 82025</b>	0.25	-*	0.26	-*	0.25	2.0	0.26	3.2	0.25	2.5

- Missing data

-\* - Only two readings are available

-\*\* - Only three readings are available

**Table 6-6. RCPT Test Results**

Bridge ID	Test Age (days)	RCPT (Coulombs)					COV (%)
		#1	#2	#3	#4	Mean	
S05 of 82191	28	4830	4670	5700	4765	<b>4994</b>	10
	56	4770	4370	4940	3700	<b>4445</b>	12
	90	5380	9720	8470	6340	<b>7478</b>	26
S06 of 82194	28	3880	3290	3350	3460	<b>3495</b>	8
	56	-	7520	7020	-	-	-
	90	-	-	-	-	-	-
S26 of 50111	28	-	9220	-	-	-	-
	56	-	-	-	-	-	-
	90	8130	5850	6410	6780	<b>6790</b>	14
S20 of 50111	28	-	10660	-	-	-	-
	56	5485	5955	6210	5740	<b>5850</b>	5
	90	7700	7020	7800	6380	<b>7230</b>	9
S05 of 82025	28	-	-	-	-	-	-
	56	5390	9080	7700	7630	<b>7440</b>	21
	90	6500	6730	9930	7190	<b>7590</b>	21

- Missing data

**Table 6-7. UPV Test Results**

Bridge ID	UPV Speed (in/sec)				
	3 Day	7 Day	28 Day	56 Day	90 Day
S06 of 82194	-	-	199,000	200,000	201,000
S26 of 50111	182,000	183,000	186,000	184,000	179,000
S20 of 50111	178,000	183,000	186,000	186,000	181,000
S05 of 82191	-	-	194,000	196,000	196,000
S05 of 82025	195,000	193,000	203,000	206,000	206,000

- Missing data

**Table 6-8. Air Permeability Test Results**

Bridge ID	Test Age (Day)	Intrinsic Gas Permeability (in <sup>2</sup> ) 10 <sup>-13</sup>					COV (%)
		#1	#2	#3	#4	Mean	
S05 of 82191	28	3.4	2.7	2.8	4.4	<b>3.3</b>	23.1
	56	3.1	3.1	4.9	4.4	<b>3.9</b>	24.0
	90	-	-	-	-	-	-
S06 of 82194	28	3.2	3.0	3.6	4.9	<b>3.7</b>	23.9
	56	5.0	4.1	4.3	5.8	<b>4.8</b>	15.5
	90	13.9	6.9	10.2	8.3	<b>9.8</b>	30.8
S26 of 50111	28	8.7	8.1	11.1	9.6	<b>9.4</b>	14.0
	56	16.3	20.8	20.5	-	-	-
	90	-	-	-	-	-	-
S20 of 50111	28	5.4	5.9	6.0	5.3	<b>5.7</b>	6.0
	56	13.4	10.4	13.2	9.4	<b>11.6</b>	17.1
	90	-	-	-	-	-	-
S05 of 82025	28	-	-	-	-	-	-
	56	2.3	3.2	3.4	3.4	<b>3.1</b>	18.1
	90	-	-	-	-	-	-

- Missing data

**Table 6-9. Absorption Test Results**

Bridge ID	Volume of Permeable Pore Space (Voids), %					
	28 day	COV (%)	56 day	COV (%)	90 day	COV (%)
<b>S05 of 82191</b>	10.7	1.7	13.5	6.4	12.4	5.1
<b>S06 of 82194</b>	10.5	3.3	11.6	14.9	12.7	8.7
<b>S26 of 50111</b>	13.4	5.0	13.2	4.5	14.0	5.7
<b>S20 of 50111</b>	12.6	5.4	12.0	4.5	12.7	2.4
<b>S05 of 82025</b>	12.4	4.9	13.1	3.2	12.3	4.0

### 6.3 CONCLUSIONS

Determination of mechanical and permeability properties of concrete is accomplished through several standard tests. Mechanical properties of deck concrete are obtained from compressive strength and elasticity modulus tests in accordance with ASTM C39 and ASTM C469 respectively. In addition, the ultrasonic pulse velocity (UPV) test is performed in compliance with ASTM C597 to evaluate relative quality of concrete and to obtain elastic properties of deck concrete. The rapid chloride permeability test (RCPT) is performed in accordance with ASTM C1202 for evaluating the concrete resistance to chloride ion penetration. Permeability properties of deck concrete are obtained from the absorption and the air-permeability tests. The absorption test is performed in compliance with ASTM C642. The air-permeability test is performed using a special apparatus not yet specified by ASTM.

The conclusions that are drawn from the test results are as follows. Grade D concrete is used for concrete bridge decks in Michigan and the design compressive strength is 4000 psi, with a 28-day strength of 4500 psi. Test results indicate that out of the five bridges monitored, in possibly three of the bridges, deck concrete gained 28-day compressive strength in excess of 6000 psi. Concrete with a 28-day compressive strength greater than 6000 psi is classified as high strength concrete and requires special construction procedures. In addition, rapid increases in compressive strength and elasticity modulus are observed. Test results show that the strength and elasticity modulus of concrete increases with the age but the concrete resistance to permeability does not improve as expected. Therefore, there is no clear correlation between mechanical and permeability properties of concrete samples obtained from field samples. Though the strength requirements are satisfied as per design codes, durability of deck concrete is uncertain.

## 7 PARAMETERS INFLUENCING DECK CRACKING

### 7.1 OVERVIEW

The findings described in the chapters of this report – Literature Review, Multi-State Survey, and Construction Monitoring, indicate that there are a limited number of factors that influence early-age cracking of reinforced concrete bridge decks. The major parameter influencing early-age deck cracking is established to be the volume change due to shrinkage and thermal effects combined with the restraints caused by the girders and boundary conditions. It is also established that early-age cracking is the leading type of distress and its reduction or prevention will improve bridge deck service life.

Shrinkage and thermal effects are inherent to concrete construction. Cement hydration is an exothermic process that generates heat and consequently a temperature difference between the concrete mass and the ambient air. As discussed in Chapter 2, several factors affect the heat magnitude that develops within the concrete mass. At a specific duration after placement, during the hydration process, the concrete mass reaches its peak temperature. Consequently, a temperature gradient is formed between the interior and the exterior surface of the deck. As a result of the cooling process, tensile stresses develop at the bottom of the deck where the restraint is the highest.

There are computational tools to estimate the level of tensile stresses that will develop at the deck-girder interface due to volume change. Krauss and Rogalla (1996) derived a group of equations for calculating the restraint in a composite reinforced concrete bridge deck subjected to uniform and linear temperature distributions. These equations first calculate the girder and reinforcement restraints. The stresses due to the restraints at the top and bottom fibers of the deck are calculated next. The formulation considers multiple layers of reinforcement in the deck to account for the restraint effects of longitudinal deck reinforcement as well as stay-in-place (metal) forms. The evaluations of these equations for a Michigan deck are described in a subsequent section.

Using the equations derived by Krauss and Rogalla (1996), tensile stress developed at the deck-girder interface of a standard 9-inch concrete deck supported on Michigan 1800 girders (Figure

7-1) is calculated. A uniform temperature distribution within the concrete deck is assumed (Figure 7-2). The peak thermal load is assumed to be reached at 12 hours after placement.

Thermal loads alone can generate significant stresses within the deck; for example, an 18 °F of differential thermal loading in conjunction with a typical girder restraint generates a tensile stress of 150 psi at the bottom of the deck. The tensile strength of concrete at early-age (12 hours after placement) can equal to the level of tensile stress developed at the bottom of the deck.

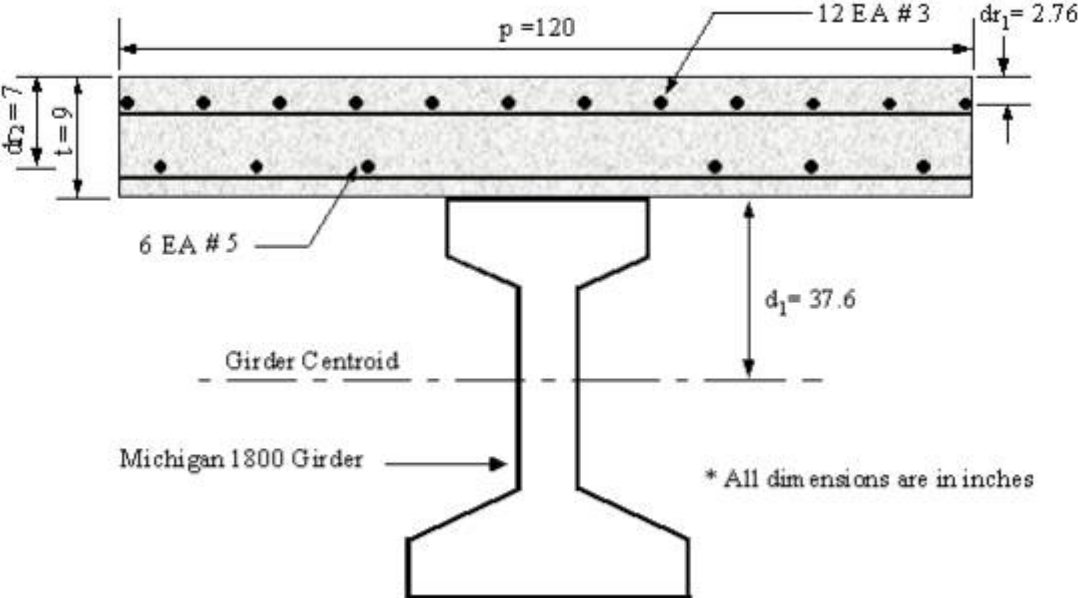
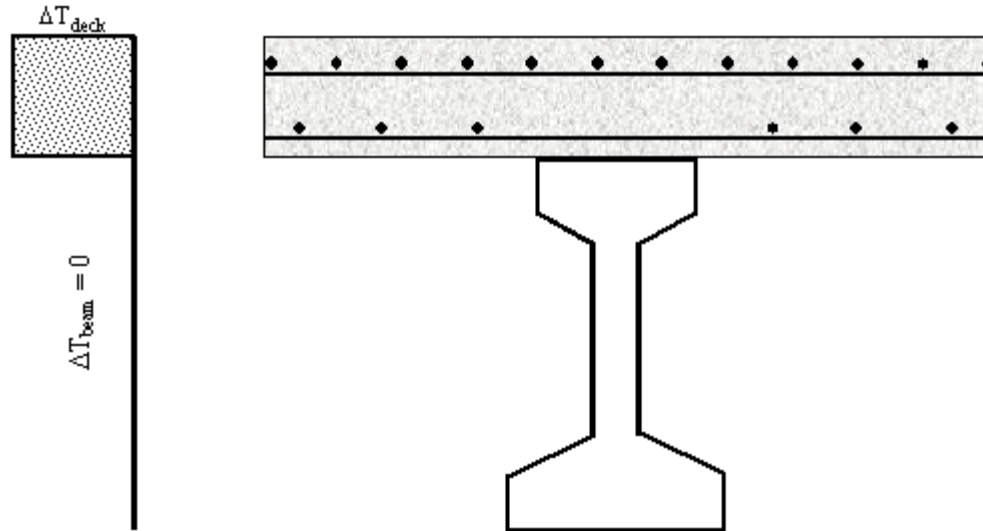


Figure 7-1. Geometry and reinforcement arrangement of the deck section supported on PCI girders



**Figure 7-2. Uniform temperature distribution within the deck**

Drying shrinkage begins as soon as concrete is placed. As discussed in Chapter 2, several factors affect drying shrinkage. Until concrete starts hardening, stresses do not develop due to lack of available restraint. When wet curing is not promptly initiated, though curing compound is applied, drying shrinkage stresses can develop. There are several shrinkage prediction models that estimate drying shrinkage following wet or moist curing. In this study, the interest is to calculate the drying shrinkage strain that forms before wet curing begins. Although, specific models for predicting the amount of very early-age drying shrinkage are not available, the formulation discussed in Chapter 2 for determination of rate of water evaporation from fresh concrete gives an indication of the importance of implementing appropriate curing procedure immediately upon concrete placement.

If drying shrinkage alone can be the cause of deck cracking at very early-age (12 hours after placement), a tensile stress of 150 psi at the bottom of the deck, which is about the same level as the tensile strength of concrete at that age, is required. Given the deck restraints from the girders and reinforcements, in order to generate a 150 psi tensile stress at the bottom of the 9-inch deck supported on Michigan 1800 girders, a drying shrinkage strain of 150 microstrain is required. According to ACI 209 (2001) the ultimate shrinkage strain of concrete is about 780 microstrain. Thus, attainment of a strain of 150 microstrain, which is 20% of ultimate shrinkage, within a day only due to drying shrinkage, is not realistic. For this reason, drying shrinkage cannot be the primary cause of deck cracking. The thermal loads must be the governing factor for early-age

deck cracking. However, the volume change due to shrinkage and thermal loading occurs simultaneously. Though the shrinkage contribution alone cannot induce cracking, the combined effects of shrinkage and thermal loading increase the cracking potential.

In order to provide a quantifiable detailed assessment of the volume change and restraint effects on early-age cracking, the knowledge of the change in the mechanical properties of concrete during early-age is important. The testing program conducted in this research obtained the compressive strength and elasticity modulus of concrete at 3, 7, 28, 56, and 90 days. The models for thermal and shrinkage effects require mechanical properties of concrete between 12 to 48 hours be known. For this reason, the estimation of compressive strength, elasticity modulus, and tensile strength of concrete at very early ages are discussed in the next section.

Shrinkage models can predict the shrinkage starting from the end of the wet or moist curing process. Although it is established that stresses due to thermal load alone can initiate deck cracking, volume change due to drying shrinkage will expose the cracks by increasing the width. Though the objective is to determine the causes of early-age deck cracking, the mitigation is not feasible unless all factors are investigated. For this purpose, the shrinkage prediction models are discussed for the quantification of shrinkage within the concrete deck upon the completion of wet curing.

## **7.2 PREDICTION MODELS FOR MECHANICAL PROPERTIES OF CONCRETE**

The purpose of using the mechanical property prediction models is to have a continuous relationship describing concrete strength and elasticity modulus (stiffness) with respect to time. The following sections explain the process for selection of the prediction models to express the variation of compressive strength and modulus of elasticity of concrete with respect to time. To understand the initiation of concrete cracking, knowledge of direct tensile strength of concrete is required. A prediction model for direct tensile strength of concrete is also presented in a following section.

### **7.2.1 Compressive Strength**

The two concrete compressive strength prediction models compared here are given by ACI and CEB-FIP.



ACI Committee 209 recommended model for moist-cured concrete made with normal Portland cement (ASTM Type I):

$$(f'_c)_t = \frac{t}{4 + 0.85t} (f'_c)_{28} \quad (7-1)$$

The relationship suggested by CEB-FIP Models Code (1990) for concrete specimens cured at 20 °C (Mehta 1993):

$$(f'_c)_t = \exp \left[ s \left( 1 - \left( \frac{28}{t/t_1} \right)^{1/2} \right) \right] (f'_c)_{28} \quad (7-2)$$

where  $(f'_c)_t$  = mean compressive strength at age  $t$  days

$(f'_c)_{28}$  = 28-day compressive strength

$s$  = coefficient depending on the cement type, such as  $s = 0.2$  for high early strength cements;  $s = 0.25$  for normal hardening cements;  $s = 0.38$  for slow hardening cements

$t$  = time in days

$t_1$  = 1-day

Both CEB-FIP and ACI 209 models require 28-day concrete strength for calculating compressive strength variation against time. A complete set of compressive strength test data is available only for three out of five bridge deck replacement projects (see Chapter 6). Therefore, CEB-FIP and ACI 209 predictions are compared with the test results obtained from deck concrete of bridges S05 of 82191, S05 of 82025, and S06 of 82194. Experimental data generated in this study shows high early-age strength. In that case, CEB-FIP Models Code (1990) requires using  $s = 0.2$  for Eq. 7-2. When  $s = 0.2$  is used, Eq. 7-2 represents a higher early-age compressive strength than Eq. 7-1. Consequently Eq. 7-2 provides more accurate predictions for 3 and 7 days than Eq. 7-1 (Figure 7-3, Figure 7-4, and Figure 7-5). Within the total time spectrum of interest, CEB-FIP model provided the best fit with the experimental results obtained in this study.

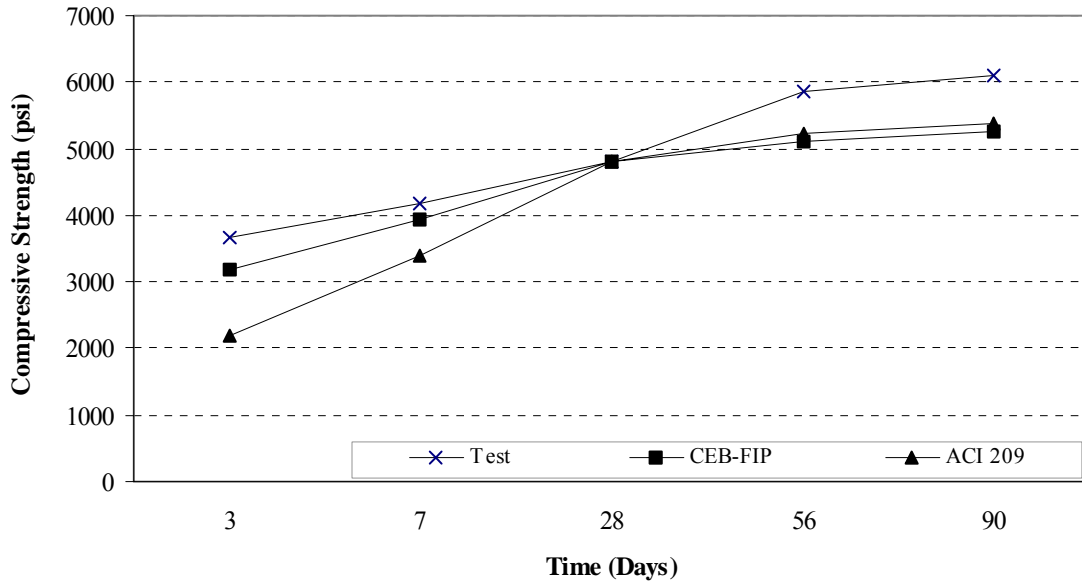


Figure 7-3. Compressive strength variation against time (S05 of 82191)

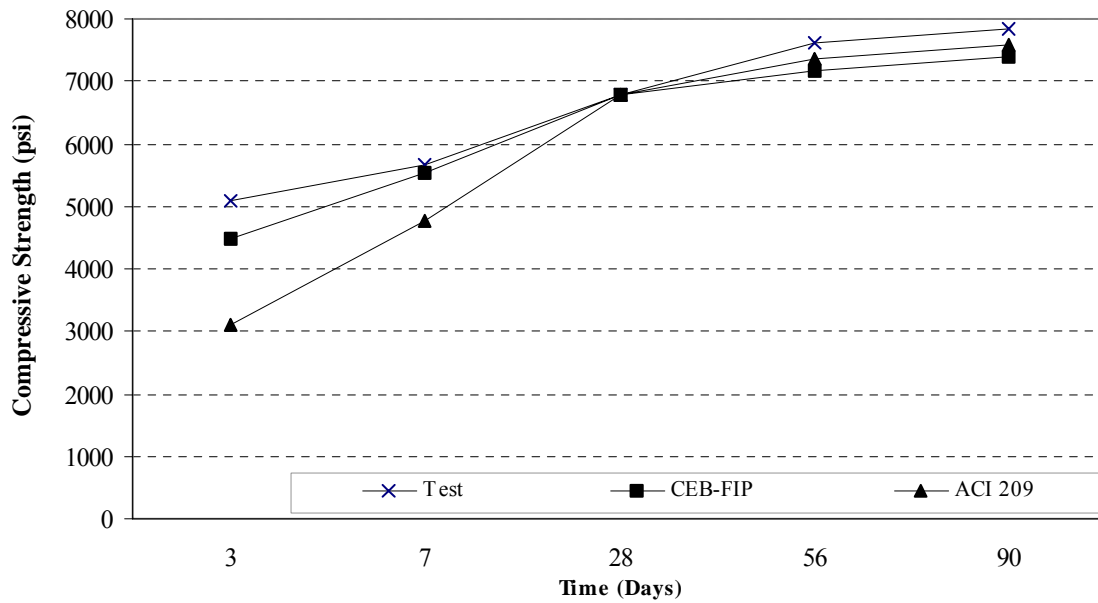


Figure 7-4. Compressive strength variation against time (S05 of 82025)

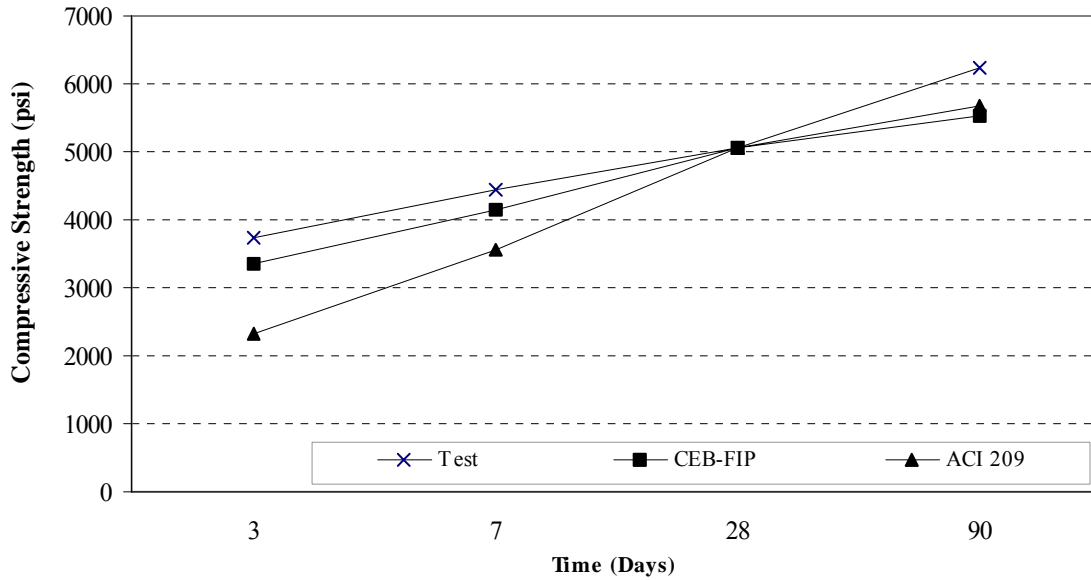


Figure 7-5. Compressive strength variation against time (S06 of 82194)

## 7.2.2 Elasticity Modulus

ACI Committee 209, ACI 318, and CEB-FIP are the most commonly used models for the prediction of static modulus of elasticity.

The model recommended by ACI Committee 209 is given as:

$$E_{ct} = g_{ct} [w^3 (f'_c)_t]^{1/2} \quad (7-3)$$

where  $w$  is the unit weight of concrete in  $pcf$  and  $g_{ct} = 33$  is a constant.

The model most commonly used in the literature and in ACI 318 is:

$$E_{ct} = 57000 \sqrt{(f'_c)_t} \quad (7-4)$$

The relationship suggested by CEB-FIP Models Code (1990) (Vincent 2003):

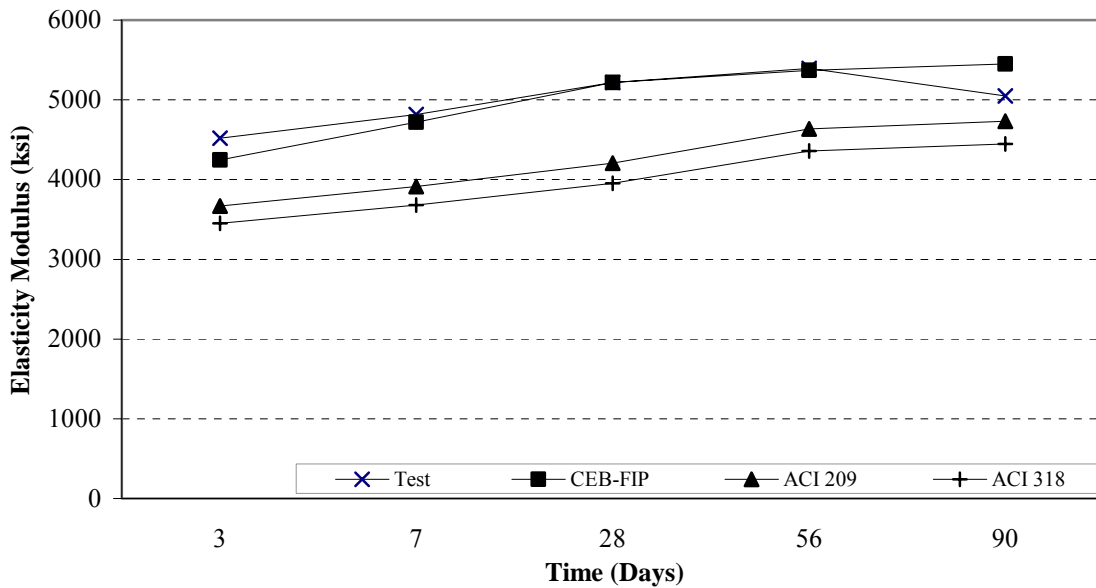
$$E_{ct} = E_c e^{[s/2(1-\sqrt{28/t})]} \quad (7-5)$$

where  $E_c$  is the mean modulus of elasticity of concrete at 28-days ( $psi$ ).

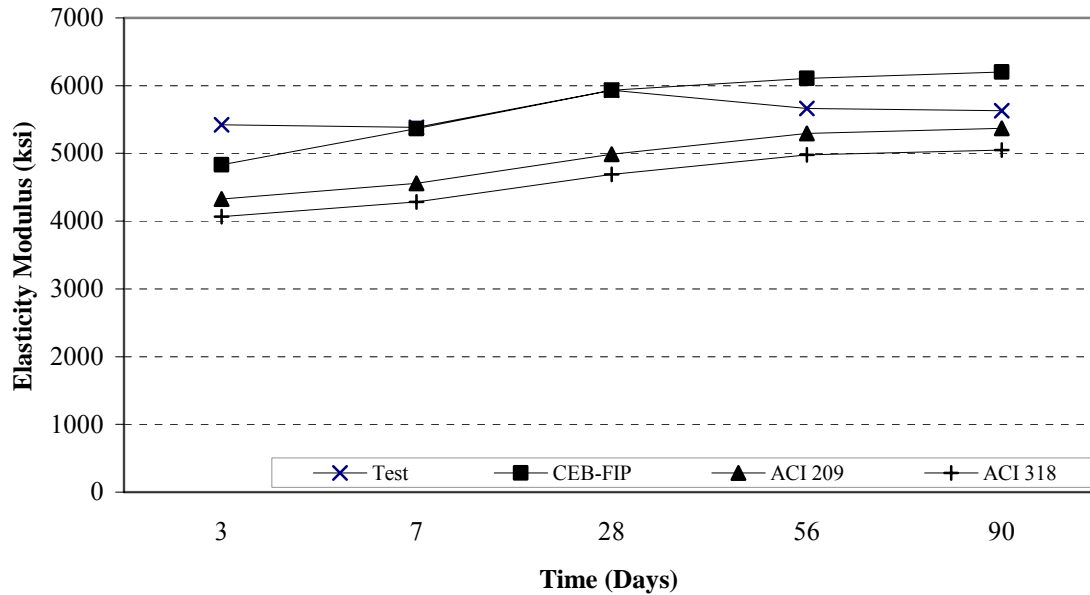
ACI 209 and ACI 318 models require concrete compressive strength for calculating variation of elasticity modulus against time. Similarly, CEB-FIP model requires 28-day mean modulus of

elasticity of concrete. A complete set of compressive strength and elasticity modulus test data is available only for two out of five bridge deck replacement projects (see Chapter 6). Therefore, CEB-FIP, ACI 318 and ACI 209 predictions are compared with the test results obtained from deck concrete of bridges S05 of 82191 and S05 of 82025.

Figure 7-6 and Figure 7-7 show the comparison of the three models with their experimental counterparts.



**Figure 7-6. Variation of elasticity modulus against time (S05 of 82191)**



**Figure 7-7. Variation of elasticity modulus against time (S05 of 82025)**

Another method for calculating the elasticity modulus is by the use of ultrasonic pulse velocity (UPV) measurements (ASTM C215-97 1998). From UPV measurement, a dynamic modulus of elasticity is calculated. A ratio of static to dynamic moduli ( $E_s/E_d$ ) is proposed by Carino (1991).

$$\frac{E_s}{E_d} = 0.368 + 0.0871 \times 10^{-6} E_s \quad (7-6)$$

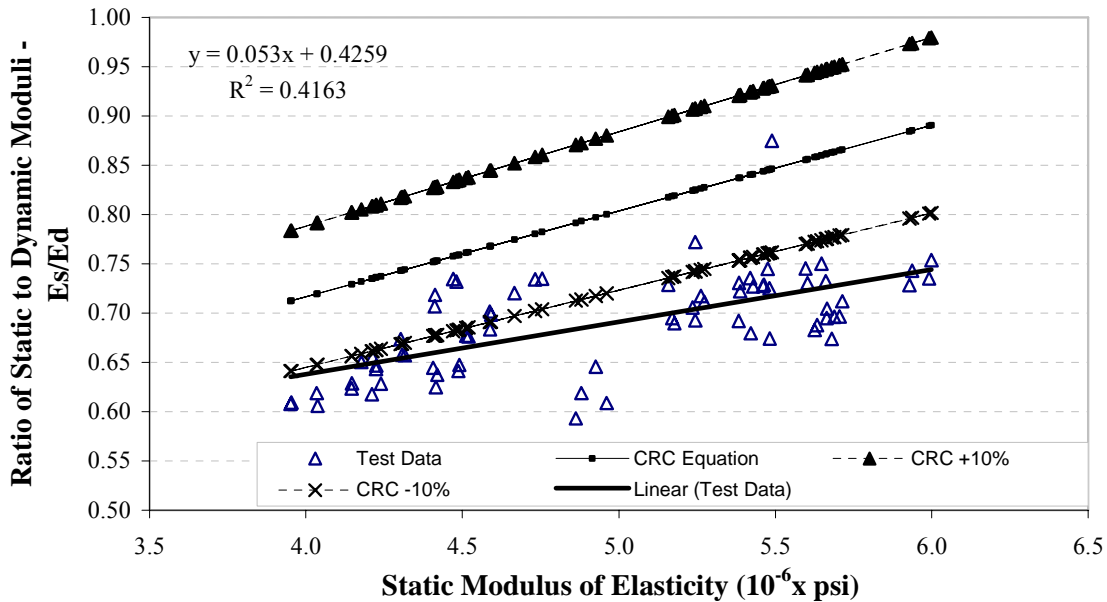
This Eq. 7-6, which is referred to as the CRC model in this document, is empirical in nature. It is proposed that the acceptable range of results is within 10% of the mean.

Table 7-1 shows the  $E_s/E_d$  ratio calculated using the data generated in this research and Eq. 7-6. The variation of test results was also compared with the applicable range proposed using the CRC model (Figure 7-8).

After the evaluation of all the potential models, CEB-FIP model provided the best fit with the experimental results obtained in this study within the total time spectrum of interest.

**Table 7-1. Ratio of Static to Dynamic Moduli**

Bridge ID	E <sub>s</sub> (ksi)	E <sub>d</sub> (ksi)	E <sub>s</sub> /E <sub>d</sub>	
			Test	Eq. (7-6)
S 05 of 82191	4213	6432	0.66	0.81
	4316	6569	0.66	0.83
	4177	6423	0.65	0.82
	4303	6387	0.67	0.83



**Figure 7-8. The comparison of CRC model predictions and the test data**

### 7.2.3 Direct Tensile Strength

ACI Committee 209 recommends the following equation for computing average values for direct tensile strength ( $f'_t$ ).

$$f'_t = g_t [w(f'_c)_t]^{1/2} \quad (7-7)$$

where  $w$  is unit weight of concrete in  $pcf$ , and  $g_t$  is given as  $1/3$ .

### 7.2.4 Concrete Strain

Assuming concrete behaves as an elastic brittle material in tension, concrete strain at cracking can be calculated using Hooke's law for tensile strength and elasticity modulus.

$$\varepsilon = f'_t / E \quad (7-8)$$

where  $\varepsilon$  is the strain,  $f'_t$  is the tensile stress, and  $E$  is the elasticity modulus.

Concrete will crack when strain due to volume change exceeds the concrete strain calculated using Eq. 7-8 and with sufficient accompanying stress due to restraint effects.

### 7.3 THERMAL STRAINS AND STRESSES

#### 7.3.1 Overview

As demonstrated in Section 7.1, the stresses developed due to thermal load of 18°F may initiate deck cracking. In order to fully evaluate thermal effect, a rigorous analysis of the cracking potential of newly placed concrete decks is performed from the data collected during construction monitoring and the early-age mechanical properties established in Section 7.2.

#### 7.3.2 Tensile Stress Development in Decks Under Thermal Loads

Krauss and Rogalla (1996) provided a system of equations to calculate the restraint in a composite reinforced concrete bridge deck subjected to uniform and linear temperature distributions. The girder and reinforcement restraints provide a means of calculation stresses at the top and bottom of the deck. The equations consider multiple layers of reinforcement in the deck to account for the restraint effects of longitudinal deck reinforcement and stay-in-place (metal) forms. These equations are based on basic mechanics principles, and only consider the decks with simply supported girders.

Eq. 7-9 to Eq. 7-13 given below are a means for calculating deck stresses under a uniform temperature distribution:

$$\varepsilon_{\text{deckBot}} = \frac{2(1-\mu^2)}{E_{\text{deck}} p t^2} \left[ -3(Q + \sum_{i=1}^{nr} (d r_i F r)_i) + t(2F + \sum_{i=1}^{nr} (F r_i)) \right] + \alpha_{\text{deck}} (1 + \mu)(T_1 - T_0) =$$

$$\frac{-1}{E_{\text{beam}}} \left( \frac{F}{A_{\text{beam}}} + \frac{d_1^2 F}{I_{\text{beam}}} + \frac{d_1 Q}{I_{\text{beam}}} \right) + \alpha_{\text{beam}} (T_2 - T_0) \quad (7-9)$$

$$\frac{6(1-\mu^2)\left[-2(Q+\sum_{i=1}^{nr}(dr_i Fr)_i)+t(F+\sum_{i=1}^{nr}(Fr)_i)\right]}{E_{deck} P t^3} = \frac{d_1 F + Q}{E_{beam} I_{beam}} \quad (7-10)$$

$$\frac{1-\mu^2}{E_{deck} P} \left[ \left( \frac{6}{t^2} - \frac{12 dr_i}{t^3} \right) \cdot \left( Q + \sum_{i=1}^{nr} (Fr_i dr_i) \right) + \left( \sum_{i=1}^{nr} (Fr_i) \right) \cdot \left( \frac{6 dr_i}{t^2} - \frac{4}{t} \right) + F \left( \frac{6 dr_i}{t^2} - \frac{2}{t} \right) \right] + \alpha_{beam} (1 + \mu)(T_1 - T_0) = \frac{Fr_i}{Ar_i E_{reinf}} + \alpha_{reinf} (Tr_1 - T_0) \quad (7-11)$$

Eq. 7-9 to Eq. 7-11 are for determining the restraint forces. The stresses at top and bottom fibers of the deck are calculated from Eq. 7-12 and Eq. 7-13 upon calculating the restraint forces.

$$f_{deckTop} = \frac{F - \sum_{i=1}^{nr} Fr_i}{A_{deck}} - \frac{Fa - Q + \sum_{i=1}^{nr} [Fr_i(a - dr_i)]}{S_{deck}} \quad (7-12)$$

$$f_{deckBot} = \frac{F - \sum_{i=1}^{nr} Fr_i}{A_{deck}} + \frac{Fa - Q + \sum_{i=1}^{nr} [Fr_i(a - dr_i)]}{S_{deck}} \quad (7-13)$$

where:

- $\alpha_{beam}$  = Coefficient of thermal expansion of the beam
- $\alpha_{deck}$  = Coefficient of thermal expansion of the deck concrete
- $\alpha_{reinf}$  = Coefficient of thermal expansion of the reinforcement
- $\epsilon_i$  = Strain in direction i, elongation positive
- $\mu$  = Poisson's ratio of the deck
- $f_i$  = Stress in direction i, tensile stresses positive
- $a$  = Half of the deck thickness, =  $t/2$
- $A_{beam}$  = Area of the beam
- $A_{deck}$  = Area of the concrete deck, =  $pt$
- $Ar_i$  = Reinforcement area of layer i
- $d_1$  = Distance to girder centroid from deck soffit
- $dr_i$  = Depth of deck reinforcement layer i, from upper surface of the deck
- $E_{beam}$  = Effective modulus of elasticity of the beam



$E_{deck}$	= Effective modulus of elasticity of the deck
$E_{reinf}$	= Effective modulus of elasticity of the deck reinforcement
$F$	= Interface shear
$Fr_i$	= Force in reinforcement layer $i$ , positive denotes tensile force
$i$	= Reinforcement layer number
$I_{beam}$	= Moment of inertia of beam
$I_{deck}$	= Moment of inertia of the deck, $= pt^3/12$
$nr$	= Number of reinforcement layers in the deck
$Q$	= Interface moment (force couple)
$S_{deck}$	= Section modulus of deck, $= pt^2/6$
$t$	= Deck thickness
$T_0$	= Initial temperature of bridge
$T_1$	= Later temperature at upper surface of deck
$T_2$	= Later temperature of beam
$Tr_i$	= Later temperature of reinforcement layer $i$

### 7.3.3 Thermal Stresses on a Typical Michigan Deck

Concrete deck reaches peak temperature at sometime during hydration. As the cooling process starts, tensile stresses develop at the bottom of the deck where the highest restraint exists. The ACI 207.2R (2001) procedure (described in Chapter 2) is used for determining the peak temperature and the time at which the peak temperature forms.

The time required for concrete to achieve peak temperature is determined from the volume to exposed-surface ratio of the bridge deck and the concrete temperature at the time of placement. The concrete temperature at the time of placement is assumed to be equal to the ambient temperature. According to ACI 207.2R (2001), the temperature of concrete placed during hot weather may exceed the mean daily ambient air temperature by 5 to 10 °F unless measures are taken to cool the concrete or the coarse aggregate. An analysis is performed considering ranges of ambient temperature as well as cement fineness. For night casting during summer months, the time to peak temperature is calculated as 12 hours within the placement temperature range that is assumed based on the ACI 207.2R (2001) requirements and the ambient temperature (Table 7-2). During late season daytime construction, the time to peak temperature is calculated to be

between 18 - 36 hours corresponding to upper and lower limits of placement temperature. Often retarders are used in the concrete mix in late season deck placement projects. It is assumed that the time to peak temperature with retarders is delayed for six hours beyond the time calculated using the ACI procedure. With the use of retarders, during late season daytime construction, the time to peak temperature is assumed to be between 24 – 42 hours (Table 7-2).

In this analysis a typical 9-inch concrete deck supported on Michigan 1800 girder is used to investigate the development of thermal stresses at the deck bottom under temperature loads. The cement content of 7 sacks/yd<sup>3</sup> and other parameters required in the thermal load calculation are given below in Table 7-2, Table 7-3, and Table 7-4.

**Table 7-2. Parameters used for Calculating Peak Differential Temperature in Deck Concrete**

Parameters	Summer (Night Casting)	Late Season (Daytime Casting)
Cement (Type 1) (lb/yd <sup>3</sup> )	658	658
Ambient Temperature Range at Placement (F)	65 - 75	40 - 55
Relative Humidity (%)	60	45
Concrete Temperature at Placement (F)	70 – 80	45 – 60
Cement Fineness (ft <sup>2</sup> /lb) (Assumed)	1173 - 1466 (2400 - 3000 cm <sup>2</sup> /g)	
Volume/Exposed- surface ratio (ft)	0.75 (for 9 in. deck)	

**Table 7-3. Mechanical Properties and Ambient Temperature at the Time of Peak Temperature**

Parameters	Summer (Night Casting)	Late Season (Daytime Casting)	
Time to Peak Temperature (hours)	12	42	24
Ambient Temperature during Concrete Peak Temperature (F)	75 - 85	30	55
Compressive Strength (psi)	1400 (at 12 hours)	3500 (at 42 hours)	2750 (at 24 hours)
Elasticity Modulus E <sub>deck</sub> (ksi)	2300 (at 12 hours)	4200 (at 42 hours)	3750 (at 24 hours)
Tensile Strength (psi)	153	242	214

**Table 7-4. Differential Deck Temperature for Construction Season and Cement Fineness**

Parameters	Summer (Night Casting)		Late Season (Daytime Casting)	
	Cement Fineness (ft <sup>2</sup> /lb)	1173	1466	1173
Ambient Air and Deck Concrete Temperature Differential $\Delta T_{deck}$ (F)	28 - 37	39 - 49	24 - 26	28 - 30

The additional parameters used in the thermal load calculations are (Figure 7-1 and Figure 7-2):

$\alpha_{beam}$  =  $6.0 \times 10^{-6}$  in./in./<sup>0</sup>F (Coefficient of thermal expansion of the concrete beam) (AASHTO 1998)

$\alpha_{deck}$  =  $8.33 \times 10^{-6}$  in./in./<sup>0</sup>F (Coefficient of thermal expansion of the deck concrete) (RILEM-42-CEA 1981)

$\alpha_{reinf}$  =  $6.7 \times 10^{-6}$  in./in./<sup>0</sup>F (Coefficient of thermal expansion of the reinforcement) (Krauss and Rogalla 1996)

$\mu$  = 0.25 (Poisson's ratio of the deck)

a =  $t/2 = 4.5$  in. (Half the deck thickness)

$A_{beam}$  =  $875$  in<sup>2</sup> (Area of the beam)

$A_{deck}$  =  $pt = 1080$  in<sup>2</sup> (Area of the concrete deck)

$Ar_1$  =  $1.32$  in<sup>2</sup> (Reinforcement area of layer 1)

$Ar_2$  =  $1.86$  in<sup>2</sup> (Reinforcement area of layer 2)

$d_1$  =  $37.6$  in. (Distance to girder centroid from deck soffit)

$dr_1$  =  $2.76$  in. (Depth of top longitudinal reinforcement from upper surface of the deck)

$dr_2$  =  $7$  in. (Depth of bottom longitudinal reinforcement from upper surface of the deck)

$E_{beam}$  =  $4000$  ksi (Effective modulus of elasticity of the concrete beam)

$E_{reinf}$  =  $29,000$  ksi (Effective modulus of elasticity of the deck reinforcement)

$I_{beam}$  =  $624,700$  in<sup>4</sup> (Moment of inertia of beam)

$I_{deck}$  =  $pt^3/12 = 7290$  in<sup>4</sup> (Moment of inertia of the deck)

p =  $120$  in. (Effective deck width)

$S_{deck}$  =  $pt^2/6 = 1620$  in<sup>3</sup> (Section modulus of deck)

t =  $9$  in. (Deck thickness)

During the period of rising concrete temperature, stay-in-place or wooden forms keep the deck edges and the bottom insulated. Thus, it is reasonable to assume that the increase in deck temperature will not affect the girder temperature. Hence, the girder temperature will be same as the ambient temperature. In addition, a uniform temperature distribution within the deck can be assumed since the deck thickness is small compared to the length and width (Figure 7-2). Based on these assumptions thermal load calculations, Eq. 7-9 – Eq. 7-11 are first solved to calculate the restraint forces. For a standard Michigan bridge deck Eq. 7-11 is solved for each reinforcement layer. Finally, Eq. 7-13 is used to calculate the stress at bottom of the deck due to the thermal load.

Assuming uniform deck temperature (Figure 7-2), Eq. 7-9 is simplified as given below:

$$\left( \frac{4(1-\mu^2)}{E_{deck} p t} + \frac{1}{E_{beam} A_{beam}} + \frac{d_1^2}{E_{beam} I_{beam}} \right) F + \left( \frac{-6(1-\mu^2)}{E_{deck} p t^2} + \frac{d_1}{E_{beam} I_{beam}} \right) Q$$

$$+ \frac{2(1-\mu^2)}{E_{deck} p t^2} (-3 d r_1 + t) F r_1 + \frac{2(1-\mu^2)}{E_{deck} p t^2} (-3 d r_2 + t) F r_2 +$$

$$\alpha_{deck} (1 + \mu) (-\Delta T_{deck}) = 0 \quad (7-14)$$

The top fiber strain of the beam is due to the force (F) and the moment (Q) developed at the deck-girder interface from the uniform thermal load (Figure 7-9). Assuming compatibility, the strain at the bottom of the deck and the top of the girder will be equal. With decreasing temperature, deck shrinkage generates tensile stresses at the deck bottom from the restraint imposed by the girder.

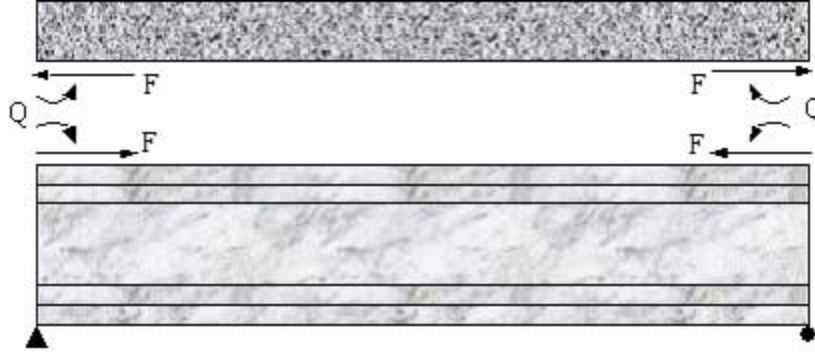


Figure 7-9. Compatibility shear force and moment at deck-girder interface

The Eq. 7-10 is also simplified using the Michigan deck parameters as follows:

$$\left( \frac{6(1-\mu^2)}{E_{deck} p t^2} - \frac{d_1}{E_{beam} I_{beam}} \right) F + \left( \frac{-12(1-\mu^2)}{E_{deck} p t^3} - \frac{1}{E_{beam} I_{beam}} \right) Q +$$

$$\frac{6(1-\mu^2)}{E_{deck} p t^3} (-2 dr_1 + t) Fr_1 + \frac{6(1-\mu^2)}{E_{deck} p t^3} (-2 dr_2 + t) Fr_2 = 0 \quad (7-15)$$

The equation is developed from the beam curvature under a uniform thermal load on the deck (i.e.,  $M/EI$ ; where  $M$  is the moment,  $E$  is the elasticity modulus, and  $I$  is the moment of inertia).

There are multiple (two) reinforcement layers and, Eq. 7-11 is solved independently for each layer. For the top layer Eq. 7-11 is written as;

$$\frac{1-\mu^2}{E_{deck} p} \left( \frac{6 dr_1}{t^2} - \frac{2}{t} \right) F + \frac{1-\mu^2}{E_{deck} p} \left( \frac{6}{t^2} - \frac{12 dr_1}{t^3} \right) Q +$$

$$\left[ \frac{1-\mu^2}{E_{deck} p} \left( \left( \frac{6}{t^2} - \frac{12 dr_1}{t^3} \right) dr_1 + \left( \frac{6 dr_1}{t^2} - \frac{4}{t} \right) \right) - \frac{1}{Ar_1 E_{reinf}} \right] Fr_1 +$$

$$\frac{1-\mu^2}{E_{deck} p} \left( \left( \frac{6}{t^2} - \frac{12 dr_1}{t^3} \right) dr_2 + \left( \frac{6 dr_1}{t^2} - \frac{4}{t} \right) \right) Fr_2 +$$

$$[\alpha_{deck}(1+\mu) - \alpha_{reinf}] (\Delta T_{deck}) = 0 \quad (7-16)$$

The uniform thermal load assumption suggests that the two layers of reinforcement and concrete deck are subjected to equal thermal load. Substituting the deck and thermal parameters in Eq. 7-11 for the top reinforcement layer, Eq. 7-16 is developed. Similarly, Eq. 7-17 is developed by substituting the parameters for the bottom reinforcement layer.

$$\frac{1-\mu^2}{E_{deck} P} \left( \frac{6 dr_2}{t^2} - \frac{2}{t} \right) F + \frac{1-\mu^2}{E_{deck} P} \left( \frac{6}{t^2} - \frac{12 dr_2}{t^3} \right) Q +$$

$$\frac{1-\mu^2}{E_{deck} P} \left( \left( \frac{6}{t^2} - \frac{12 dr_2}{t^3} \right) dr_1 + \left( \frac{6 dr_2}{t^2} - \frac{4}{t} \right) \right) Fr_1 +$$

$$\left[ \frac{1-\mu^2}{E_{deck} P} \left( \left( \frac{6}{t^2} - \frac{12 dr_2}{t^3} \right) dr_2 + \left( \frac{6 dr_2}{t^2} - \frac{4}{t} \right) \right) - \frac{1}{Ar_2 E_{reinf}} \right] Fr_2 +$$

$$[\alpha_{deck}(1+\mu) - \alpha_{reinf}] (\Delta T_{deck}) = 0 \quad (7-17)$$

Equations 7-14, 7-15, 7-16 and 7-17 can now be solved simultaneously for F, Q, Fr<sub>1</sub>, and Fr<sub>2</sub>. These parameters are then substituted in Eq. 7-13 to calculate the stress at the bottom of the deck. The results of the thermal load analysis are summarized below in Table 7-5.

In Table 7-5 two cement different fineness values (1173 ft<sup>2</sup>/lb and 1466 ft<sup>2</sup>/lb) are used in the calculations. The lower fineness value leads to lower heat of hydration thus defined on the lower bound solution and vice versa. Different ambient temperature bounds were assumed for night casting in the summer and daytime casting in late-season construction. The deck placement projects that are carried out during late October and November are defined as late season construction. The time required for concrete to reach peak temperature is calculated based on cement type, volume to exposed-surface ratio of the deck, and the concrete temperature at the time of placement. ACI 207.2R (2001) requirements and the assumed ambient temperature range are used to establish the concrete temperature at the time of placement. For night casting, the time to peak temperature is calculated as 12 hours within the concrete temperature range of 65-75 °F at the time of placement, whereas for daytime casting, the peak temperature is achieved between 18 - 36 hours corresponding to upper and lower limits of concrete temperature during

the time of placement. Retarders are more commonly used in the concrete mix during late season construction. For late season construction, six hours are added to the time values calculated from the ACI procedure to account for the effects of retarders.

The calculated thermal load for a cement fineness of 1173 ft<sup>2</sup>/lb and ambient temperature of 65 °F is 28 °F. For the same cement fineness and ambient temperature of 75 °F, the thermal load is 37 °F. This range of thermal load (28 – 37 °F) develops a tensile stress range in the deck of 237-313 psi as shown in Table 7-5. The tensile stress developed in the bridge deck is greater than the concrete tensile strength (refer column 2 of Table 7-5). Similar interpretations can be drawn for the data shown in the other columns of Table 7-5.

When cement fineness increases, rate and amount of strength and elasticity modulus gain as well as heat generated during hydration process increase. The effect of fineness on heat of hydration is accounted in the models given in ACI 207.2R (2001). However, the models used to predict the strength and elasticity modulus of concrete against time do not account this factor, hence, same values are used under different cement fineness values.

**Table 7-5. Stress Developed at the Bottom of the Deck due to Thermal Effects (7 Sacks of Cement)**

Parameters (1)	Summer (Night Casting)		Late Season (Daytime Casting)	
	Lower Bound (2)	Upper Bound (3)	Lower Bound (4)	Upper Bound (5)
Cement Fineness (ft <sup>2</sup> /lb)	1173	1466	1173	1466
Ambient Temperature Range (F)	65 - 75	65 - 75	40 - 55	40 - 55
Time to Peak Temperature (hours)	12	12	42	24
Difference in Ambient and Deck Concrete Temperature $\Delta T_{deck}$ (F)	28 - 37	39 - 49	24 - 26	28 - 30
<b>Tensile Stress (psi)</b>	<b>237 - 313</b>	<b>329 - 414</b>	<b>263 - 285</b>	<b>292 - 313</b>
<b>Tensile Strength (psi)</b>	<b>153</b>	<b>153</b>	<b>242</b>	<b>214</b>

### 7.3.3.1 Effect of Cement Content on Thermal Stresses

The effects of reducing the cement content are investigated for contents of 6 sacks (564 lb/yd<sup>3</sup>) and 4 sacks (376 lb/yd<sup>3</sup>) under constant water/cement ratio. Mechanical properties of concrete for 4 and 6 sacks of cement are given in Table 7-6 and Table 7-7.

**Table 7-6. Mechanical Properties of Concrete with 6 Sacks of Cement**

Parameters	Summer (Night Casting)		Late Season (Daytime Casting)	
Time to Peak Temperature (hours)	12	42	24	
Compressive Strength (psi)	1215	3033	2383	
Elasticity Modulus (ksi)	2131	3758	3348	
Tensile Strength (psi)	142	225	199	

**Table 7-7. Mechanical Properties of Concrete with 4 Sacks of Cement**

Parameters	Summer (Night Casting)		Late Season (Daytime Casting)	
Time to Peak Temperature (hours)	12	42	24	
Compressive Strength (psi)	795	1983	1558	
Elasticity Modulus (ksi)	1724	2538	2250	
Tensile Strength (psi)	115	182	161	

When 6 sacks of cement are used, the calculated thermal load is 24 °F, for a cement fineness of 1173 ft<sup>2</sup>/lb and an ambient temperature of 65 °F. For the same cement fineness, if ambient temperature is increased to 75 °F, the thermal load is increased to 31 °F. At this thermal load range (24 – 31 °F), the range of tensile stress developed in the deck is calculated to be 196-253 psi. The tensile stress in the bridge deck is greater than the tensile strength of 142 psi. Under similar exposure conditions and cement fineness, if 4 sacks of cement are used, the range is reduced to 14 – 19 °F and the range of tensile stress developed in the deck is 104-141 psi (refer column 2 of Table 7-8). The stresses due to thermal load are about equal to the tensile strength of 115 psi. Similar interpretation can be drawn for the data shown in the other columns of Table 7-8.



**Table 7-8. Stress Developed at the Bottom of the Deck due to Thermal Effects (6 Sacks & 4 Sacks of Cement)**

Parameters (1)	Summer (Night Casting)		Late Season (Daytime Casting)	
	Lower Bound (2)	Upper Bound (3)	Lower Bound (4)	Upper Bound (5)
Cement Fineness (ft <sup>2</sup> /lb)	1173	1466	1173	1466
Ambient Temperature Range (F)	65 - 75	65 - 75	40 - 55	40 - 55
Time to Peak Temperature (hours)	12	12	42	24
<b>6 sacks of cement</b>				
Difference in Ambient and Deck Concrete Temperature $\Delta T_{deck}$ (F)	24 - 31	33 - 42	22 - 25	26
<b>Tensile Stress (psi)</b>	<b>196 - 253</b>	<b>270 - 343</b>	<b>230 - 261</b>	<b>258</b>
<b>Tensile Strength (psi)</b>	<b>142</b>	<b>142</b>	<b>225</b>	<b>199</b>
<b>4 sacks of cement</b>				
Difference in Ambient and Deck Concrete Temperature $\Delta T_{deck}$ (F)	14 - 19	20 - 26	16 - 22	23
<b>Tensile Stress (psi)</b>	<b>104 - 141</b>	<b>149 - 193</b>	<b>141 - 194</b>	<b>192</b>
<b>Tensile Strength (psi)</b>	<b>115</b>	<b>115</b>	<b>182</b>	<b>161</b>

Analysis results given in Table 7-8 show that the use of lower cement content lowers the thermal load significantly but the tensile stresses are still in excess of tensile strength. Tensile strength and modulus of elasticity are also lower for concrete with 4 and 6 sacks of cement. It is possible to achieve lower tensile stress using coarse cements. The highest fineness used for these calculations is 1466 ft<sup>2</sup>/lb (3000 cm<sup>2</sup>/g). Use of the fineness value of cement is limited to 1466 ft<sup>2</sup>/lb by the graphs provided in ACI 207.2R (2001) for calculation of the peak temperature and the age of concrete at peak temperature. The cement mill reports (see Appendix C) obtained from the concrete supplier indicate the fineness of cement of 1774 ft<sup>2</sup>/lb (3630 cm<sup>2</sup>/g). An increase in the cement fineness further increases the level of heat generated within the concrete mass, resulting in a greater thermal load. Though not accounted in the analysis, increase in cement fineness results higher rate and amount of strength and elasticity modulus gain.

### 7.3.3.2 Effect of Girder Type on Thermal Stresses

The analysis performed on a typical 9-inch deck supported on Michigan 1800 girder showed that the thermal stresses at bottom of the deck is sufficiently high enough to cause early-age deck

cracking. Generally, three types of girders are used in Michigan with 9-inch concrete decks – PCI, PC spread box, and steel. Further analysis on thermal stress development is performed in order to investigate the effects of girder types on deck cracking due to thermal loading. Figure 7-1, Figure 7-10, and Figure 7-11 show the geometric properties and the reinforcement arrangements within the bridge decks. Table 7-9 Summarizes the geometric properties of bridge decks supported on various girder types.

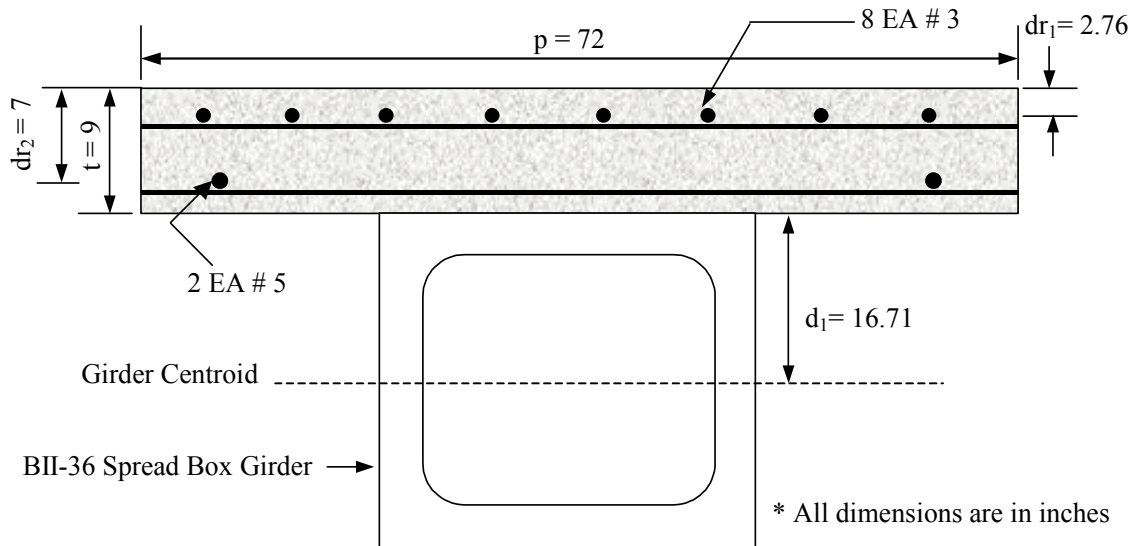


Figure 7-10. Geometry and reinforcement arrangement of the deck section supported on PC spread box girders

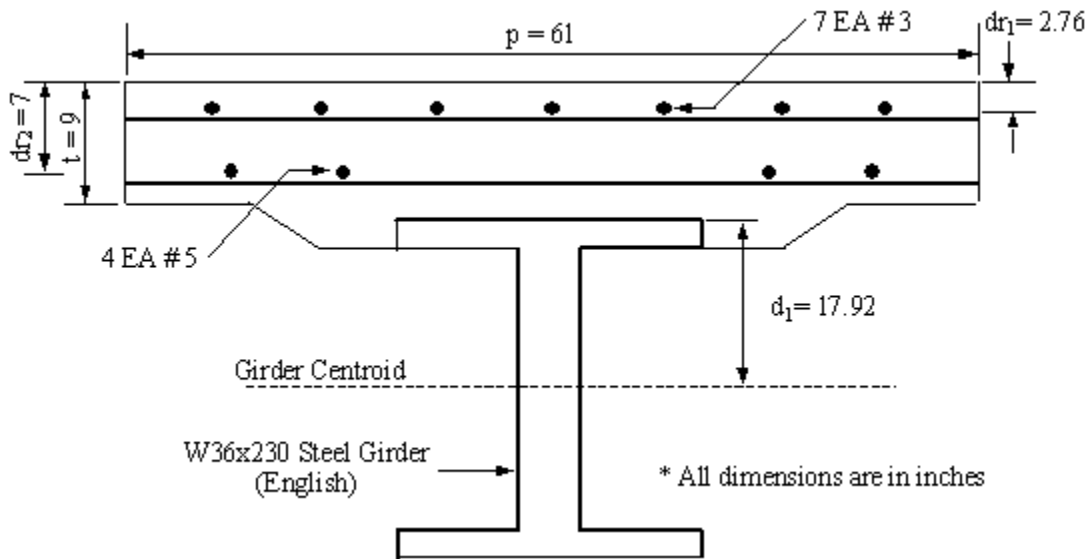


Figure 7-11. Geometry and reinforcement arrangement of the deck section supported on steel girders

**Table 7-9. Summary of Geometric Properties of Bridge Decks**

<b>Girder Type</b>	<b>t (in)</b>	<b>p (in)</b>	<b>A<sub>beam</sub> (in<sup>2</sup>)</b>	<b>A<sub>deck</sub> (in<sup>2</sup>)</b>	<b>A<sub>r1</sub> (in<sup>2</sup>)</b>	<b>A<sub>r2</sub> (in<sup>2</sup>)</b>	<b>d<sub>1</sub> (in)</b>	<b>d<sub>r1</sub> (in)</b>	<b>d<sub>r2</sub> (in)</b>	<b>I<sub>beam</sub> (in<sup>4</sup>)</b>	<b>I<sub>deck</sub> (in<sup>4</sup>)</b>	<b>S<sub>deck</sub> (in<sup>3</sup>)</b>
<b>PCI</b>	9	120	875	1080	1.32	1.86	37.6	2.76	7	624,700	7290	1620
<b>Spread Box</b>	9	72	620.5	648	0.88	0.62	16.71	2.76	7	85,153	4374	972
<b>Steel</b>	9	61	67.6	549	0.77	1.24	17.95	2.76	7	15,000	3706	824

With the given geometric properties and early-age mechanical properties of concrete (compressive strength of 1400 psi and elasticity modulus of 2300 ksi), and a 25 °F uniform thermal load on the deck, tensile stress magnitudes at the deck-girder interface are calculated and given in Table 7-10 below.

**Table 7-10. Tensile Stress Developed at Girder-Deck Interface**

<b>Girder Type</b>	<b>Tensile Stress at Girder-Deck Interface (psi)</b>
<b>PCI</b>	211
<b>Spread Box</b>	249
<b>Steel</b>	260

According to this analysis, the bridge decks supported on PCI girders have the least potential to crack under thermal loading while decks with steel girders show the highest potential.

### 7.3.3.3 Effect of Girder Spacing on Thermal Stresses

The analysis is performed on a typical 9-inch deck supported on W36x230 girders. Three different girder spacings were considered - 61-, 71-, and 91-inches. Summary of bridge deck geometric properties are given in Table 7-11.

**Table 7-11. Summary of Geometric Properties of Bridge Decks**

<b>Girder Spacing (in)</b>	<b>t (in)</b>	<b>p (in)</b>	<b>A<sub>beam</sub> (in<sup>2</sup>)</b>	<b>A<sub>deck</sub> (in<sup>2</sup>)</b>	<b>A<sub>r1</sub> (in<sup>2</sup>)</b>	<b>A<sub>r2</sub> (in<sup>2</sup>)</b>	<b>d<sub>1</sub> (in)</b>	<b>d<sub>r1</sub> (in)</b>	<b>d<sub>r2</sub> (in)</b>	<b>I<sub>beam</sub> (in<sup>4</sup>)</b>	<b>I<sub>deck</sub> (in<sup>4</sup>)</b>	<b>S<sub>deck</sub> (in<sup>3</sup>)</b>
<b>61</b>	9	61	67.6	549	0.77	1.24	17.95	2.76	7	15,000	3706	824
<b>71</b>	9	71	67.6	639	0.88	1.55	17.95	2.76	7	15,000	3706	824
<b>91</b>	9	91	67.6	819	1.10	1.86	17.95	2.76	7	15,000	3706	824

With the given geometric properties and early-age mechanical properties of concrete (compressive strength of 1400 psi and elasticity modulus of 2300 ksi), and a 25 °F uniform thermal load on the deck, tensile stress magnitudes at the deck-girder interface are calculated and given in Table 7-12 below.

**Table 7-12. Tensile Stress Developed at Girder-Deck Interface**

<b>Girder Spacing (in)</b>	<b>Tensile Stress at Girder-Deck Interface (psi)</b>
<b>61</b>	260
<b>71</b>	253
<b>91</b>	249

According to the analysis, increased girder spacing reduces the restraint effects on the deck and reduces the tensile stress at deck-girder interface due to volume change loads.

## **7.4 METHODS FOR ESTIMATING SHRINKAGE STRAIN**

### **7.4.1 Overview**

To improve the design of bridge decks, the material behavior under drying has to be characterized more accurately. Even though predictions of humidity may not be very accurate, the shrinkage strains that develop is dependent on the humidity of the environment (Bissonette 1999). Performance-based specifications, on shrinkage limits, will be useful for control of deck cracking (Mokarem et al. 2003).

The shrinkage predictions of concrete are based on ACI 209 and CEB-FIP models. Other models reported in the literature are derived from these two (Hani et al. 2003). Some researchers tried to evaluate shrinkage under different curing procedures. Mokarem et al. (2003) used crushed limestone gravel and diabase in concrete mixes in order to see the effects of aggregate type. For all types of aggregate, CEB-FIP model was found to be a better predictor than ACI 209. Although, ACI 209 is considered poor in overall prediction of drying shrinkage, Hani et al. (2003) suggested it is a good predictor for 28-day shrinkage. On the other hand, the CEB-FIP is a good prediction model for early ages.

The mathematical formulations of prediction models are similar. Each model has an ultimate shrinkage calculation that predicts total long-term shrinkage for given strength and cement type.

For different cement types and mix designs, ultimate shrinkage is a constant only in ACI 209. The shrinkage is a time-dependent function with its value based on drying time of concrete. The drying time of concrete is the difference between its age ( $t$ ) and duration of wet curing ( $t_c$ ). The shape of the concrete element is incorporated in shrinkage models as volume to exposed-surface ratio. The relative humidity component is represented as the average humidity of the environment. There are several limitations to the various shrinkage prediction models that are described in Table 7-13.

**Table 7-13. Limitations of Shrinkage Prediction Models**

Parameter (1)	ACI 209 (2)	CEB-FIP 90 (3)	Bazant B3 (4)	GL 2000 (5)
Mean 28-day compressive strength $f'_c$ psi	NA*	2,900 – 13,000	2,500 – 10,000	2,900 – 10,000
Aggregate/Cement	NA	NA	2.5 – 13.5	NA
Cement lbs/ft <sup>3</sup>	NA	NA	10 – 45	NA
Water/cement ratio	NA	NA	0.3 - 0.85	NA
Relative Humidity (%)	40-100	40-100	40-100	40-100
Cement Type	I or III	R, SL, or RS	I, II, or III	I, II, or III
Age of concrete at which the shrinkage strain is interested ( $t$ ) or age at which concrete starts drying ( $t_c$ ) (Moist cured)	$\geq 7$ days	$t_c \leq 14$ days	$t_c \leq t$	$\geq 2$ days
$t$ or $t_c$ (Steam cured)	$\geq 1-3$ days	$t_c \leq 14$ days	$t_c \leq t$	$\geq 2$ days
Additional Notes				Aggregate stiffness is considered

\* Model does not account for the parameter

#### 7.4.1.1 ACI 209 Prediction Model

ACI 209 is an empirical approach to calculate total free shrinkage of concrete:

$$\epsilon_{sh}(t) = \left[ \frac{t - t_c}{35 + (t - t_c)} \right] \cdot \epsilon_u \quad (7-18)$$

where  $t$  is the age of concrete,  $t_c$  is the duration of wet cure, and  $\epsilon_u$  is the ultimate shrinkage.

The value of ultimate shrinkage ( $\epsilon_u$ ) is a constant (780  $\mu$  strain) for all types of concrete and curing conditions. Ultimate shrinkage is corrected only by a humidity factor as given below in Table 7-14:

**Table 7-14. The Relationship Between Humidity Range and Correction Formula**

Humidity Range	Correction Formula $\gamma_{RH}$
40% < RH < 80%	1.40 – RH/100
80% < RH < 100%	3.00 – 3xRH/100

$$\epsilon_u = 780 \times 10^{-6} \times \gamma_{RH}$$

ACI formulation is based on a 7-day wet curing duration and no correction is provided for different curing durations. Practically speaking, it is difficult to undertake long-term field curing of concrete.

#### 7.4.1.2 Bazant B3 Model

The Bazant B3 formulation was developed from analytical statistical evaluation (Bazant 1995). Ultimate shrinkage has been calculated based on the type of cement, curing, water content, and 28-day standard strength:

$$\epsilon_{sh}(t) = \epsilon_u \cdot k_h \cdot S(t) \quad (7-19)$$

Ultimate shrinkage is formulated as follows:

$$\epsilon_u = \alpha_1 \cdot \alpha_2 [26 w^{2.1} \cdot (f'_c)^{-0.28} + 270] \text{ (in } 10^{-6}) \quad (7-20)$$

Shrinkage is a function of cement type ( $\alpha_1$ ), curing conditions ( $\alpha_2$ ), water content (w), and 28-day strength ( $f'_c$ ).

**Table 7-15. Coefficients  $\alpha_1$  and  $\alpha_2$  used in Bazant B3 Model**

ASTM C 150 type cements	$\alpha_1$	Curing coefficient	$\alpha_2$
Type I	1	Steam cured concretes	0.75
Type II	0.85	Water cured or RH 100 %	1.0
Type III	1.1	Sealed specimens	1.2

The component  $k_h$  is related to the humidity of the environment, and calculated as follows:

$$k_h = 1 - h^3 \quad (7-21)$$

The humidity correction is made when the humidity is less than 0.98. For determining swelling of concrete in a relative humidity of 100%,  $k_h$  is given as 0.2.

The time function of shrinkage  $S(t)$  is a function of concrete age ( $t$ ), duration of wet cure ( $t_c$ ), and shrinkage time coefficient ( $\gamma_{sh}$ ).

$$S(t) = \tanh \left( \sqrt{\frac{t - t_c}{\gamma_{sh}}} \right) \quad (7-22)$$

Shrinkage time coefficient  $\gamma_{sh}$  is size dependent as given below:

$$\gamma_{sh} = (k_s \cdot D)^2 \quad (7-23)$$

where  $D$  is the square of two times the volume to exposed-surface ratio as formulated below, and  $k_s$  is a cross-section shape factor. For simple members similar to slabs,  $k_s$  can be assumed to be 1.

$$D = 4 (v/s)^2 \quad (7-24)$$

The formulation incorporates almost all factors affecting shrinkage, but is not suggested for early-age predictions since mathematical approximation includes an intrinsic error for early ages (Bazant 2001).

#### 7.4.1.3 CEB-FIP 90 Model

The European Concrete Committee formulation is one of the most powerful shrinkage prediction formulas (Shah et al. 1996). The formulation of CEB-FIP 90 is as follows:

$$\epsilon_{sh}(t) = \epsilon_u \cdot \beta_{RH} \cdot \beta_s(t) \quad (7-25)$$

This formulation is similar to the Bazant B3 prediction formula. It incorporates an ultimate shrinkage ( $\epsilon_u$ ) and humidity coefficient ( $\beta_{RH}$ ) as well as a time dependent shrinkage function  $\beta_s(t)$ . In this formulation, ultimate shrinkage is given as follows:

$$\epsilon_u = \left[ 160 + 10 \beta_{sc} \cdot \left( 9 - \frac{f'_c}{1450} \right) \right] \cdot 10^{-6} \quad (7-26)$$

where  $\beta_{sc}$  is the cement type factor and  $f'_c$  is the 28-day strength of concrete.

The cement type factor is established for European cement standards. It is transformed for the ASTM designated cement types as given below:

**Table 7-16. Cement Type Coefficient used in CEB-FIP 90 Model**

Type of cement	$\beta_{sc}$
Low heat development cements (Type II and Type V)	4
Rapid heat development cements Type I and Type III	5

Relative humidity factor is calculated as follows:

$$\beta_{RH} = 1 - \left( \frac{RH}{100} \right)^3 \quad (7-27)$$

The time dependent shrinkage function is given as follows:

$$\beta_s(t) = \left[ \frac{t - t_c}{350 \left( \frac{h}{3.937} \right)^2 + (t - t_c)} \right]^{0.5} \quad (7-28)$$

where  $t$  is age of concrete,  $t_c$  is duration of wet cure and  $h$  is volume to exposed-surface ratio dependent coefficient:

$$h = 2 v/s \quad (7-29)$$

The CEB-FIP formulation is a very accurate method for predicting shrinkage, since the formulation covers almost all factors that may affect shrinkage. The results of this formulation are in close agreement with the Bazant B3 formulation in the long term (Mokarem et al. 2003 and Hani et al. 2003). In addition, the CEB-FIP 90 model is quite accurate for early-age predictions of shrinkage (Hani et al. 2003).



#### 7.4.1.4 Gardner – Lockman Model

The Gardner –Lockman model was proposed in 2001 (Gardner et al. 2001). This prediction model is also known as the Gardner model. Formulation is as follows:

$$\epsilon_{sh}(t) = \epsilon_u \beta(h) \beta_s(t) \quad (7-30)$$

The ultimate shrinkage coefficient ( $\epsilon_u$ ) is calculated as:

$$\epsilon_u = 1000 K \sqrt{\frac{4350}{f'_c}} \cdot 10^{-6} \quad (7-31)$$

where  $K$  is cement type coefficient and  $f'_c$  is the concrete mean compressive strength at 28-day, (psi). Cement type coefficient ( $K$ ) is given in the table below:

**Table 7-17. Cement Type Coefficient used in Gardner-Lockman Model**

Type of cement	K
Type I	1.00
Type II	0.70
Type III	1.15

Other components are humidity and time coefficients and are formulated below:

$$\beta_h = 1 - 1.18 \left( \frac{h}{100} \right)^4 \quad (7-32)$$

$$\beta_s(t) = \sqrt{\frac{t - t_c}{(t - t_c) + 97 (vs)^2}} \quad (7-33)$$

where  $h$  is relative humidity,  $vs$  is volume to exposed-surface ratio,  $t$  is age of concrete, and  $t_c$  is duration of wet cure. Recent research on this model indicates that this formulation is useful in estimating shrinkage of concrete containing low heat pozzolans (fly ash, slag, etc) (Mokarem et al. 2003).

## 7.4.2 Shrinkage and Cracking Relationship

Recent research done by the Virginia DOT on performance of concrete mixes tries to correlate restraint shrinkage and free shrinkage. The concrete mixes were subjected to the same curing conditions and they were measured for restraint and free shrinkage. After the free shrinkage amount exceeded 200 microstrain, the probability of cracking in the restraint shrinkage sample increased. Concrete designs were suggested to limit free shrinkage to reduce the cracking probability (Mokarem et al. 2003).

In order to evaluate effects of curing periods on 28 days of shrinkage for a 9-inch deck concrete, shrinkage calculations were performed as shown in Table 7-18, assuming that 28-day concrete strength is 5000 psi with Type 1 cement and wet cured 2 days, 7 days, and 14 days. The MDOT structural concrete design requires 7 days wet cure. In shrinkage calculations, a relative humidity of 60 % is assumed.

**Table 7-18. Predicted Shrinkages for Different Curing Periods**

ACI 209 (Microstrain)	CEB-FIP 90 (Microstrain)	Bazant B3 (Microstrain)	Gardner & Lockman (Microstrain)	Curing duration (days)
266	32	27	45	2
234	29	26	41	7
178	23	22	33	14

Using ACI 209 as a benchmark, a free shrinkage of 266 microstrain for 2 day wet cure and 178 microstrain for 7 day wet cure can be calculated. The additional free shrinkage will generate additional stresses due to restraints of girders and/or deck forms. This increase at an early-age is more significant since concrete is immature and has low tensile strength.

The influence of wet curing duration on shrinkage is also shown in Figure 7-12. As seen in Figure 7-12, the duration of wet cure reduces the early-age shrinkage without any change in ultimate shrinkage. The reason for increase in duration of wet curing to help reducing shrinkage cracking is because the tensile strength of concrete will develop with increased concrete maturity; therefore, the stress developed due to shrinkage and associated restraint will not cause cracking.

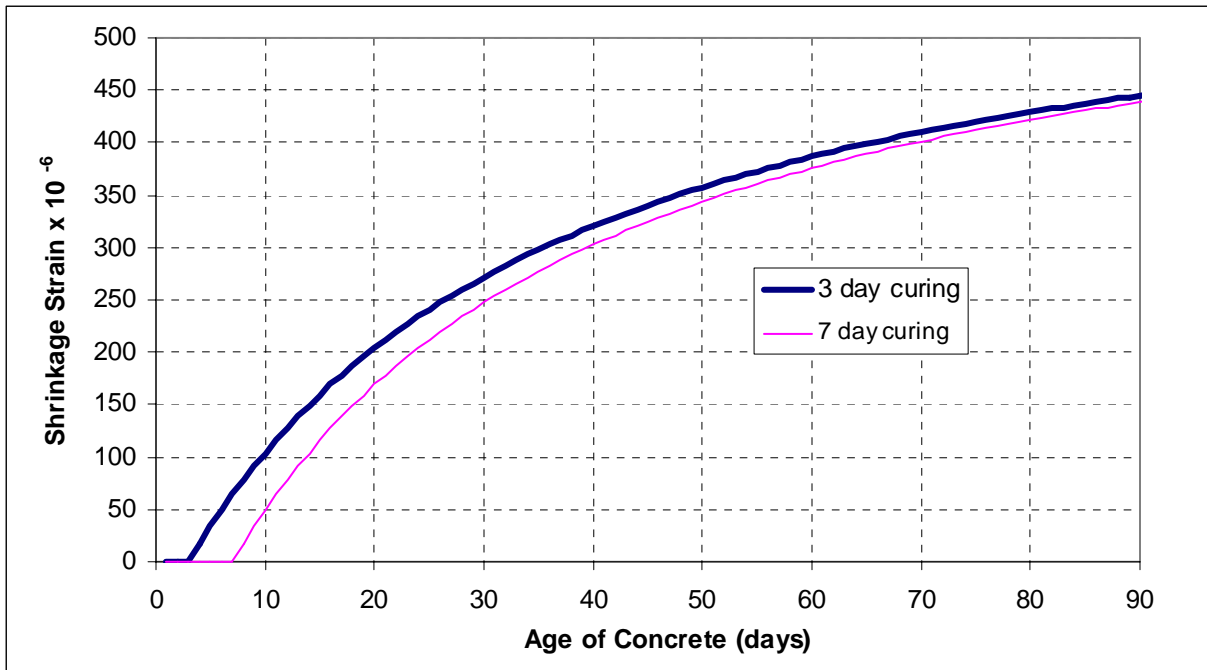


Figure 7-12. Effects of wet curing duration – shrinkage predicted by ACI model

## 7.5 CONCLUSIONS

The summaries of previous chapters – Literature Review, Multi-State Survey, and Construction Monitoring, point towards a factor that influences early-age cracking of reinforced concrete bridge decks. The primary cause of early-age deck cracking is identified as the volume change due to shrinkage and thermal effects. Volume change in concrete under restraint induces tensile stress. Early-age cracking is identified as the leading cause of other types of distress, and the reduction or prevention of this type of cracking will improve bridge deck service life.

The analysis presented in this research demonstrated that the tensile stress due to early-age thermal load alone can cause deck cracking. Volume change of concrete due to temperature and shrinkage occurs simultaneously. An increase in drying shrinkage due to construction errors and delays in wet cure can increase the tensile stresses. Drying shrinkage, beyond the very early ages, will increase with crack widths that have formed due to thermal loads.

The time concrete reaches peak temperature during hydration depends, among other parameters, on the volume to exposed-surface ratio and the concrete temperature at the time of placement. Volume to exposed-surface ratio of concrete is very small for bridge decks. For small volume to

exposed-surface ratio, the percent absorbed or dissipated heat between concrete and ambient temperatures at the time of placement is very high. In that case, the concrete temperature at the time of placement quickly reaches the ambient temperature. Consequently, the measured concrete temperature before placement does not play a major role in predicting early-age concrete properties. The ambient temperature at the time of concrete placement governs the early-age concrete thermal properties. Based on this finding, the concrete parameters controlling the thermal load are the cement type, content, and fineness, ambient temperature at the time of concrete placement, and the time of inception of curing. These parameters govern the temperature rise in bridge deck concrete during the hydration process. The temperature difference between peak temperature within the concrete mass and the ambient temperature establishes the thermal load on the deck. The thermal load controls the magnitude of the tensile stress developed at the deck. The thermal load depends on the maximum temperature developed within the concrete mass and the ambient temperature at the time of concrete achieving peak temperature. Use of retarders in the concrete mix delays the hydration process. Use of retarders may be an advantage or a drawback depending on the ambient temperature at the time of peak hydration temperature. Today's weather prediction technology can be utilized as a decision tool in using admixtures that can refine the hydration process in order to minimize the thermal load.

Analysis performed with lower cement amounts of 4 and 6 sacks shows that this reduction will reduce thermal load. However, the stresses developed under the reduced thermal load can still exceed the tensile strength of concrete. Further analysis is performed to find out the vulnerability of different girder-deck combinations to early-age bridge deck cracking due to volume change. When standard mix design (grade D) is used, the PCI girder-deck combination has the lowest potential for deck cracking, while the steel girder-deck combination has the highest. Further, increased girder spacing reduces the stress developed at the deck-girder interface due to volume change loads.

## **8 SUMMARY & CONCLUSIONS**

### **8.1 SUMMARY**

The need for this research was based on the observed deck deterioration mechanism that is accelerated by the presence of cracks. The primary objective of this research was to identify the major parameters influencing the cracking of the reinforced concrete (RC) deck. The second objective was to state recommendations to manage these parameters that are within the control of the bridge designer, the materials engineer, the contractor, and/or the maintenance engineer in order to maximize deck life. The project tasks consisted of literature review, nationwide survey on the subject of RC deck cracking, field inspection and data collection of existing RC bridge decks that were replaced within the last five years, monitoring the construction of new decks, laboratory and field testing of concrete samples, and establishing the parameters influencing deck cracking.

### **8.2 CONCLUSIONS**

The results of this research first of all confirmed the observations of the Michigan Department of Transportation engineers that the deck cracks become visible within the first few months of construction. This research established the mechanism by which these cracks form as thermal stresses that develop during the cement hydration process and, in most cases, during the first 12 to 24 hours upon concrete placement. The research recommendations focused on the means of reducing the thermal stresses in order to control deck cracking by development of a project specific concrete mix design that accounts not only for the current ambient temperature but also incorporates the temperature predictions during the next 12 to 24 hours. Thermal effects and its adverse impact are already recognized and certain requirements of current practice like the night placement during summer months are useful practices and should be continued. Naturally, these recommendations will only be effective by full compliance with the Michigan Department of Transportation – Standard Specifications for Construction, especially the requirements related to curing.

A nationwide survey conducted in this research revealed that, transverse cracking is the most prevalent type of cracking observed on the deck. Most of the responding State DOTs emphasized changing the mix design in order to reduce cracking. Of the respondent states, 45%

have been using fly ash and 29% GGBS in their mix design. The most popular type of chemical admixture among the responding State DOTs is air entrainment, which is similar to Michigan's practice. The predominant causes of early-age deck cracking identified by the responding states in the order of significance are as substandard curing, construction practices, and mix design.

The field inspection data generated in this research showed that most bridge decks are cracked. In most cases, the crack widths and density are high enough to dramatically increase the ingress of the aggressive agents into the deck interior, initiate deterioration, and reduce its service life. However, the field inspection data could not identify any operational and design parameters that influence RC deck cracking. These parameters included average daily truck traffic (ADTT) volume, span type (simple or continuous), span length, structure type (steel or prestressed concrete beams), deck thickness, and skew angle.

During the monitoring of construction of decks, it was observed that the Michigan Department of Transportation – Standard Specifications for Construction are often not adhered to. The observed violations that significantly impact the cracking potential of the deck are, in the order of frequency of violation: delays in the start of the wet curing process, lack of sufficient moisture in the burlap during the curing process, and delays in application of the curing compound.

Concrete placement near the construction or expansion joint boundaries was observed to be quite problematic. During the floating process excess concrete overflows the joints, loses its plasticity and is scraped off and thrown in with the deck concrete near the joint. This creates a substandard concrete quality near the joint, which is where deterioration often starts. Continuous concrete placement without construction and expansion joints should be investigated. Joints can be opened by saw cutting upon concrete hardening.

The testing of the concrete samples prepared during the monitoring of the deck construction showed that the concrete properties are approaching high strength with rapid early strength gain. This is a concern because these mixtures generate higher heat of hydration, and increased drying shrinkage. The 28-day concrete strength was measured to be in excess of 6,000 psi, which is considered to be high-strength concrete, and needs to comply with special construction and curing procedures.

It is recommended that the following steps be taken based on these findings:

1. Education of project consultants to ensure the enforcement of the current Michigan Department of Transportation – Standard Specifications for Construction related to RC bridge deck placement. Portions of the Michigan Department of Transportation – Standard Specifications for Construction related to concrete placement, finishing, and curing may be reorganized as describing the requirements in an order starting from the most significant to least significant in terms of its impact on the quality of the hardened concrete.
2. Implementation of measures to control thermal stresses and shrinkage stresses in RC decks. These measures should be decided based upon a comprehensive review of all benefits and drawbacks. The measures should include the reduction and/or substitution of cement with mineral admixtures; re-grading coarse aggregates for reducing mortar volume; and use of current and forecast weather data in optimizing the mix design and placement time. Also, limitations to set-retarding chemical admixtures need to be established so that wet curing can practically be initiated before build-up of thermal load.
3. A further inspection study to cover a large number of existing decks to identify the relative importance of operational parameters influencing deck cracking. This study should use a sample on the order of hundreds to cover the entire state.

## **9 SUGGESTIONS FOR FUTURE RESEARCH**

There are two major recommendations for research that should follow this study. The first recommendation is to undertake an immediate project to develop mix parameters optimized for the reduction of thermal and shrinkage loads. This new study should also include the development of tools that will utilize the current and forecasted climatic data, as well as cement and aggregate properties in order to determine an optimized, project-specific mix design.

The field inspection of twenty bridges could not provide sufficient data to understand the relationship between crack density and bridge skew, span length, and ADTT. It is suggested that a continuation research project be undertaken to investigate these parameters on a much larger sample space, as many as 100 bridge decks.



## 10 REFERENCES

Abdun-Nur, E.A. (1982). "Incentive specifications for concrete." *Concrete International*, Vol. 4, No.9, pages 20-24.

Abdun-Nur, E.A. (1982). "Inspection and quality assurance." *Concrete International*, Vol. 4, No.9, pages 58-62.

Abel, J., and Hover, K. (1998). "Effect of Water-Cement Ratio on the Early Age Tensile Strength of Concrete." *TRB Annual Meeting practical papers*.

ACI Committee 211, 211.1-97. (2001). "Standard Practice for Selecting Proportions for Normal, Heavyweight and Mass Concrete." *ACI Manual of Concrete Practice*, American Concrete Institute, Detroit, Michigan.

ACI Committee 212, 212.3R-91. (2001). "Chemical Admixtures for Concrete." *ACI Manual of Concrete Practice*, American Concrete Institute, Detroit, Michigan.

ACI Committee 221, 221R-96, (2001). "Guide for Use of Normal Weight and Heavyweight Aggregates in Concrete." *ACI Manual of Concrete Practice*, American Concrete Institute, Detroit, Michigan.

ACI Committee 223, 223-98. (2001). "Standard Practice for the Use of Shrinkage-Compensating Concrete." *ACI Manual of Concrete Practice*, American Concrete Institute, Detroit, Michigan.

ACI Committee 224, 224.IR-84. (2001). "Causes, Evaluation and Repair of Cracks in Concrete." *ACI Manual of Concrete Practice*, American Concrete Institute, Detroit, Michigan.

ACI Committee 224, 224.R-01, (2001). "Control of Cracking in Concrete Structures." *ACI Manual of Concrete Practice*, American Concrete Institute, Detroit, Michigan.

ACI Committee 225, 225R-99. (2001). "Guide to Selection and Use of Hydraulic Cements." *ACI Manual of Concrete Practice*, American Concrete Institute, Detroit, Michigan.

ACI Committee 226, 226.1R-87. (2001). "Ground Granulated Blast Furnace Slag as a Cementitious Constituent in Concrete." *ACI Manual of Concrete Practice*, American Concrete Institute, Detroit, Michigan.

ACI Committee 232, 232.2R-96. (2001). "Use of Fly Ash in Concrete." *ACI Manual of Concrete Practice*, American Concrete Institute, Detroit, Michigan.

ACI Committee 233, 233R-03. (2003). "Slag Cement in Concrete Mortar." *ACI Manual of Concrete Practice*, American Concrete Institute, Detroit, Michigan.

ACI Committee 234, 234R-96. (2001). "Guide for the Use of Silica Fume in Concrete." *ACI Manual of Concrete Practice*, American Concrete Institute, Detroit, Michigan.

ACI Committee 308, 308.1-98. (1986). "Standard Specification for Curing Concrete." *ACI Manual of Concrete Practice*, American Concrete Institute, Detroit, Michigan.

Adkins, D. F., and Christiansen, V. T. (1989). "Freeze-Thaw Deterioration of Concrete Pavements." *Journal of Materials in Civil Engineering*, Vol. 1, No. 2, pp. 97-104.

Adkins, D. F., and Merkley, G. P. (1990). "Mathematical Model of Temperature Changes in Concrete Pavements." *Journal of Transportation Engineering*, Vol. 116, Issue 3, pp. 349-358.

Adkins, D. F., Merkley, G. P., and Brito, G. P. (1993). "Mathematics of Concrete Scaling." *Journal of Materials in Civil Engineering*, Vol. 5, Issue 2, pp. 280-288.

Aïtcin, P. C. (2000). "Cements of yesterday and today concrete of tomorrow." *Cement and Concrete Research*, Vol. 30, Issue 9, pp. 1349-1359.

Aitcin, P.C. (2003). "The durability characteristics of high performance concrete: a review." *Cement and Concrete Composites*, Vol. 25, pp. 409-420.

Akhras, N. M. (1998). "Detecting freezing and thawing damage in concrete using signal energy." *Cement and Concrete Research*, Vol. 28, Issue 9, pp. 1275-1280.

Alampalli, S., and Owens, F. (2000). "Increasing Durability of Concrete Decks Using Class HP Concrete." *Concrete International*, Vol. 22, Issue 7.

Al-Khaja, W. A. (1997). "Influence of temperature, cement type and level of concrete consolidation on chloride ingress in conventional and high-strength concretes." *Construction and Building Materials*, Vol. 11, Issue 1, pp. 9-13.

Allan, M.L. (1995). "Probability of corrosion induced cracking in reinforced concrete." *Cement and Concrete Research*, Vol. 25, Issue 6, pp. 1179-1190.

Almusallam, A. A. (2001). "Effect of environmental conditions on the properties of fresh and hardened concrete." *Cement and Concrete Composites*, Vol. 23, Issues 4-5, pp. 353-361.

Almusallam, A. A. (2001). "Effect of environmental conditions on the properties of fresh and hardened concrete." *Cement and Concrete Composites*, Vol. 23, pp. 353.

Alsayed, S.H. (1998). "Influence of superplasticizer, plasticizers, and silica fume on the drying shrinkage of high strength concrete subjected to hot-dry field conditions." *Cement and Concrete Research*, Vol. 28, No. 10, pp. 1405–1415.

Altoubat, S. A., and Lange, D. A. (2001). "Creep, Shrinkage, and Cracking of Restrained Concrete at Early Age." *ACI Materials Journal*, Vol. 98, Issue 4.

Anguelov, P. (1995). "Roller form technology for concrete construction." *Concrete International*, Vol. 17, Issue 10, pp. 50-54.

*ASHRAE Handbook of Fundamentals*. Atlanta: American Society of Heating Refrigerating and Air Conditioning Engineers, Inc. 1992.

ASTM C215-97. (1998). "Standard Test Method for Fundamental Transverse, Longitudinal, and Torsional Frequencies of Concrete Specimens." ASTM International, 100 Barr Harbor Drive, P.O.Box C700, West Conshohocken, Pennsylvania, USA

Babaei, K., and Fouladgar, A. M. (1997). "Solutions to Concrete Bridge Deck Cracking." *Concrete International*, Vol. 19, No. 7, pp. 34.

Babaei, K., and Hawkins, N. M. (1987). "Evaluation of Bridge Deck Protective Strategies." *NCHRP Report 297*, Transportation Research Board, National Research Council, Washington, D.C.

Banthia, N., Yan, C., and Mindess, S. (1996). "Restrained shrinkage cracking in fiber reinforced concrete: a novel test technique." *Cement and Concrete Research*, Vol. 26, Issue 1, pp. 9-14.

Basheer, P. A. M., Chidiact, S. E., and Long, A. E. (1996). "Predictive model for deterioration of concrete structures." *Construction and Building*, Vol. 10, pp. 27-37.

Bazant, Z. (1995). "Creep and shrinkage prediction model for analysis and design of concrete structures – Model B3." *Materials and Structures*, Vol. 28, pp. 357-365.

Bazant, Z. (2001). "Prediction of creep and shrinkage: past, present and future." *Nuclear Engineering and Design*, Vol. 203, pp. 27-38.

Bentz, D. P., Garbaczi, E. J., Haecker, C. J., and Jensen, O.U.M. (1999). "Effects of cement particle size distribution on performance properties of portland cement based materials." *Cement and Concrete Research*, Vol. 29, pp. 1663-1671.

Bentz, D. P., and Snyder, K. A. (1999). "Protected paste volume in concrete extension to internal curing using saturated lightweight fine aggregate." *Cement and Concrete Research*, Vol. 29, Issue 11, pp. 1863-1867.

Berke, N. S., and Roberts, L. R. (1989). "Use of Concrete Admixtures to Provide Long-Term Durability from Steel Corrosion." *ACI Special Publication (SP-119-20)*, pp.384-403.

Bhal, N.S., and Mital, N.K. (1996). "Effect of relative humidity on creep and shrinkage of concrete." *Indian Concrete Journal*, Vol. 70, pp. 21-27.

Bissonnette, B., Pierre, P., and Pigeon, M. (1999). "Influence of key parameters on drying of cementitious materials." *Cement and Concrete Research*, Vol. 29, pp. 1655-1662.

Bolander, J.E. Jr., and Le, B.D. (1999). "Modeling crack development in reinforced concrete structures under service loading." *Journal of Construction and Building Materials*, Vol. 13, pp. 23-31.

Borrowman, P. E., Seeber, K. E., and Kesler, C. E. (1977). "Behavior of Shrinkage-Compensating Concretes Suitable for use in Bridge Decks." *Department of Theoretical and Applied Mechanics*, University of Illinois, Urbana, Illinois, T. and A.M. Report No. 416.

Boulware, B. L., and Nelson, B. H. (1979). *Factors Affecting the Durability of Concrete Bridge Decks: Shrinkage Compensated Cement Concrete in Bridge Deck*. Interim Report No. 5. California Department of Transportation, FHWA/CA/SD-79/18.

Brozzetti, J. (2000). "Design development of steel-concrete composite bridges in France." *Journal of Constructional Steel Research*, Vol. 55, Issues 1-3, pp. 229-243.

Burke, M. P. Jr. (1999). "Cracking of concrete decks and other problems with integral-type bridges." *Transportation Research Record*, pp. 131.

Cady, P. D., and Carrier, R. E. (1971). *Durability of Bridge Deck-concrete-Part 2: Moisture Content of Bridge Decks*. Final Report. Department of Civil Engineering, Pennsylvania State University.

Cady, P.D., Carrier, R.E., Bakr, T., and Theisen, J. (1971). *Durability of Bridge Decks-Part 1: Effect of Construction Practices on Durability*. Final Report. Department of Civil Engineering, Pennsylvania State University.

Cai, H., and Liu, X. (1998). "Freeze-thaw durability of concrete: ice formation process in pores." *Cement and Concrete Research*, Vol. 28, Issue 9, pp. 1281-1287.

Campbell-Allen, D., and Lau, B. (1978). *Cracks in Concrete Bridge Decks*. Research Report R313, Department of Civil Engineering, University of Sydney.

Carlson, R. W. (1940). "Attempts to Measure the Cracking Tendency of Concrete." *Journal of the ACI*, Vol. 36, No. 6, pp.533-540.

Chapman, R. A., and Shah, S. P. (1987). "Early-age bond strength in reinforced concrete." *ACI Materials Journal*, Vol. 84, Issue 6.

Chatterji, S. (1999). "Aspects of freezing process in porous material-water system (Part 2. Freezing and properties of frozen porous materials)." *Cement and Concrete Research*, Vol. 29, Issue 5, pp. 781-784.

Cheng, T. T., and Johnston, D. W. (1985). *Incidence Assessment of Transverse Cracking in Bridge Decks: Construction and Material Considerations*. North Carolina State University, Department of Civil Engineering, Raleigh, North Carolina, FHWA/NC/85-002 Vol. 1.

Committee on the Comparative Costs of Rock Salt and Calcium Magnesium Acetate (CMA) for Highway Deicing, (1991). *Highway Deicing Comparing Salt and Calcium Magnesium Acetate*. NCHRP Special Report 235, Transportation Research Board.

"Concrete Network", (2003).

[http://woncretenetwork.com/concrete/concreteadmixtures/crack\\_control.htm](http://woncretenetwork.com/concrete/concreteadmixtures/crack_control.htm).

Costa, A., and Appleton, C. J. (2002). "Case studies of concrete deterioration in a marine environment in Portugal." *Cement and Concrete Composites*, Vol. 24, Issue 1, pp. 169-179.

Coutinho, A. de S. (1959). "The Influence of the Type of Cement on its Cracking Tendency." *RILEM Journal*, New Series No. 5.

Cusick, R.W., and Kesler, C. E. (1980). "Behavior of Shrinkage Compensating Concretes Suitable for Use in Bridge Decks." *ACI Special Publication (SP-64-15)*. American Concrete Institute, Detroit, Michigan, pp.293-310.

Cusson, D., and Repette, W. (2000). "Early-Age Cracking in Reconstructed Concrete Bridge Barrier Walls." *ACI Materials Journal*. Vol. 97, Issue 4.

Cusson, D., and Mailvaganam, N.P. (1999). "Corrosion-inhibiting systems." *Concrete International* , Vol. 21, Issue 8, pp. 41-47.

Dakhil, F. H., Cady, P. D., and Carrier, R. E. (1975). "Cracking of Fresh Concrete as Related to Reinforcement." *Journal of the ACI*, pp. 421-428.

De Schutter, G., and Taerwe, L. (1996). "Estimation of Early-Age Thermal Cracking Tendency of Massive Concrete Elements By Means of Equivalent Thickness." *ACI Materials Journal*, Vol. 93, Issue 5.

Dhir, R.K., Hewlett, P.C., and Dyer, T.D. (1995). "Durability of 'self-cure' concrete." *Cement and Concrete Research*, Vol.25, pp. 1153-1158.

Ding, Y., Kusterle, W. (1999). "Comparative study of steel fiber-reinforced and steel mesh reinforced concrete at early ages panel tests." *Cement and Concrete Research*, Vol.29, issue 11, pp. 1827-1834.

Dry, C. M. (1999). "Repair and prevention of damage due to transverse shrinkage cracks in bridge decks." *Proceedings of SPIE - The International Society for Optical Engineering*, Vol. 3671, pp. 253.

Edwards, D.L. (2000). "HPC on bridges: The Florida experience." *Concrete International*, Vol. 22, Issue 2, pp. 63-65.

EN Committee, prEN 206-1: 2000E. (2000). "Concrete: Specification, performance, production and conformity." European Committee for Standardization, Brussels.

Engelund, S., and Sorensen, J.D. (1998) "A probabilistic model for chloride ingress and initiation of corrosion in reinforced concrete structures." *Structural Safety*, Issue 20, pp. 69-89.

Enright, M. P., and Frangopol, D. M. (1998). "Probabilistic analysis of resistance degradation of reinforced concrete bridge beams under corrosion." *Engineering Structures*, Vol. 20, Issue 11, pp. 960-971.

Forster, S. W. (2000). "HIPERPAV-Guidance to Avoid Early-Age Cracking in Concrete Pavements." *ACI Special Publication*, Vol. 192.

Fouad, F. H., and Furr, H. L. (1986). "Behavior of Portland Cement Mortar in Flexure at Early Ages." *ACI Special Publication (SP-9-5-6)*, American Concrete Institute, Detroit, Michigan, pp. 93-113.

Fowler, D.W. (1999). "Polymers in concrete a vision for the 21<sup>st</sup> century." *Cement and Concrete Composites*, Vol. 21, pp. 449-452.

Fraczek, J. (1979). "ACI survey of concrete structure errors." *Concrete International*, Vol. 1, Issue 12.

Freidin, C. (1999). "Hydration and strength development of binder on high calcium oil fly ash Part II: Influence of curing conditions on long term stability." *Cement and Concrete Research*, Vol. 29, Issue 11, pp. 1713-1719.

Freidin, C. (2001). "Effect of aggregate on shrinkage crack-resistance of steam cured concrete." *Magazine of Concrete Research*, Vol. 53, pp. 85.

French, C., Eppers, L., Le, Q., and Hajjar, J. (1999). "Transverse Cracking in Bridge Decks." *TRB Annual Meeting practical papers*.

Fu, Z. (1998). "Slipform pavement construction in China." *Concrete International*. Vol. 20, Issue 5, pp. 36-38.

Furr, H. L., and Fouad, F. H. (1982). "Effect of Moving Traffic on Fresh Concrete During Bridge-Deck Widening." *Transportation Research Record 860*, pp. 28-36.

Furtak, K. (1999). "Assessment of crack state in RC slabs of composite bridges." *Archives of Civil Engineering*, Vol. 45, pp. 59.

Gardner, N.J., and Lockman, M.J. (2001). "Design provisions for drying shrinkage and creep of normal strength concrete." *ACI Materials Journal*, Vol. 98, No.2, pp. 159-167.

Ghaffori, N., and Mathis, R. (1998). "Prediction of Freezing and Thawing Durability of Concrete Paving Blocks." *Journal of Materials in Civil Engineering*, Vol. 10, Issue 1, pp. 45-51.



- Gilbert, R. I. (2001). "Shrinkage, Cracking and Deflection- The Serviceability of Concrete Structures." *Electronic Journal of Structural Engineering*, Vol. 1, No. 1, pp. 2-14.
- Gilbert, R. I. (1992). "Shrinkage Cracking in Fully Restrained Concrete Members." *ACI Structural Journal*, Vol. 89, No. 2, pp. 141-149.
- Gowripalan, N. V., Sirivivatnanon, C., and Lim, C. (2000). "Chloride diffusivity of concrete cracked in flexure." *Cement and Concrete Research*, Vol. 30, Issue 5, pp. 725-730.
- Gratton-Bellew, P.E. (1996). "Microstructural investigation of deteriorated Portland Cement concretes." *Construction and Building Materials*, Vol.10, No. 1, pp. 3-16.
- Guenot, L., Torrenti, J. M., and Laplante, P. (1996). "Stresses in Early-Age Concrete: Comparison of Different Creep Models." *ACI Materials Journal*, Vol. 93, Issue 3.
- Hani, N., Suksawang, N., and Mohammed, M. (2003). "Effects of curing methods on early age and drying shrinkage of high performance concrete." *TRB 2003 Annual meeting CD-Rom*.
- Hansen, T. C., and Mattock, A. H. (1966). "Influence of Size and Shape of Member on the Shrinkage and Creep of Concrete." *Journal of the ACI*, Vol. 63. [Also *PCA Development Department Bulletin D103*, Portland Cement Association].
- Hanson, J. A., Elstner, R. C., and Clore, R. H. (1973). "The Role of Shrinkage Compensating Cement in Reduction of Cracking of Concrete." *ACI Special Publication (SP-38-12)* American Concrete Institute, Detroit, Michigan, pp. 251-271.
- Haque, M.N. (1996). "Strength development and drying shrinkage of high strength concretes." *Cement and Concrete Composites*, Vol.18, pp. 333-342.
- Hawks, N.F., Teng, T.P., Bellinger, W.Y., and Rogers, R.B. (1993). *Distress identification manual for the long term pavement performance project*, Strategic Highway Research Program, SHRP-P-338.
- Healy, R. J., and Lawrie, R. A. (1998). "Bridge Cracking: A Dot Experience and Perspective." *Concrete International*, Vol. 20, No. 9, pp. 37-40.

Ho, D. W. S., and Chirgwin, G. J. (1996). "A performance specification for durable concrete." *Construction and Building Materials*, Volume 10, Issue 5, Pages 375-379.

Ho, D. W. S., and Chirgwin, G. J., and Mak, L.S. (1997). "Water sorptivity of heat cured concrete for bridge structures." *ACI Special Publication (SP-171)*, Paper 3, pp. 97-108.

Hoff, G.C., Bilodeau, A., and Malhotra, M. (2000). "Elevated temperature effects on HSC residual strength." *Concrete International*, Vol. 22, Issue 2, pp. 41-47.

Holley, J.J., Thomas, M.D.A., Hopkins, D.S., Cail, K.M., and Lanctot, M. C. (1999). "Custom HPC mixtures for challenging bridge design." *Concrete International*, Vol. 21, No. 9, pp. 43-48.

Holt, E.E., and Janssen, D. J. (1998). "Influence of Early Age Volume Changes on Long-Term Concrete Shrinkage." *TRB Annual Meeting practical papers*.

Hong, K., and Hooton, R. D. (1999). "Effects of cyclic chloride exposure on penetration of concrete cover." *Cement and Concrete Research*, Vol. 29, Issue 9, pp. 1379-1386.

Hong, K., and Hooton, R. D. (2000). " Effects of fresh water exposure on chloride contaminated concrete." *Cement and Concrete Research*, Vol. 30, pp. 1199-1207.

Horn, M. W., Stewart, C. F., and Boulware, R. L. (1975). *Factors Affecting the Durability of Concrete Bridge Decks*. Construction Practices-Interim Report No. 4. Bridge Department, California Division of Highways, CA-DOT-ST-4104-4-75-3.

Horn, M. W., Stewart, C. F., and Boulware, R. L. (1972). *Webber Creek Deck Crack Study-Final Report*. State of California, Business and Transportation Agency, Department of Public Works, in Cooperation with the FHWA, Research Report CA-HWY-BD-624102 (2)-72-2.

Horn, M. W., Stewart, C. F., and Boulware, R. L. (1972). *Factors Affecting the Durability of Concrete Bridge Decks: Normal vs. Thickened Deck*-Interim Report No. 3. Bridge Department, California Division of Highways, CA-HY-4101-3-72-11.

Hue, F., Serrano, G., and Bolaño, J. A. (2000). "Öresund Bridge. Temperature and cracking control of the deck slab concrete at early ages." *Automation in Construction*, Vol. 9, Issues 5-6, pp. 437-445.

Hughes, B. P., and Mahmood, A. T. (1988). "Laboratory investigation of early thermal cracking of concrete." *ACI Materials Journal*, Vol. 85, Issue 3.

Igarashi, S., Kubo, H.R., and Kawamura, M. (2000). "Long-term volume changes and microcracks formation in high strength mortars." *Cement and Concrete Research*, Vol. 30, pp. 943-951.

Irwin, R. J., and Chamberlin, W. P. (1981). *Performance of Bridge Decks with 3-inch Design Cover*. New York State Dept. of Transportation, Report No. FHWA/NY/RR-81/93.

Issa, M. A. (1999). "Investigation of cracking in concrete bridge decks at early ages." *Journal of Bridge Engineering*, pp. 116.

Issa, M.A., Yousif, A.A., and Issa, M.A. (2000). "Effect of construction loads and vibrations on new concrete bridge decks." *Journal of Bridge Engineering*.

Jacobsen, S., and Sellevold, E.J. (1996). "Self healing of high strength concrete after deterioration by freeze/thaw." *Cement and Concrete Research*, Vol. 26, Issue 1, pp. 55-62.

Jauregui, D.V. (2001). "A field-testing system for experimental bridge evaluation." *Experimental Techniques*, Vol. 25, pp.37.

Jaycox, C.E. (1982). "Guidance in the establishment of an inspection program." *Concrete International*, Vol. 4, No. 9, pp. 79-83.

Jeknavorian, A., and Barry, E. F. (1999). "Determination of durability-enhancing admixtures in concrete by thermal desorption and pyrolysis gas chromatography-mass spectrometry." *Cement and Concrete Research*, Vol. 29, Issue 6, pp. 899-907.

Jensen, O. M., and Hansen, P. F. (1999). "Influence of temperature on autogenous deformation and relative humidity change in hardening cement paste." *Cement and Concrete Research*, Vol. 29, Issue 4, pp. 567-575.

Jones, M. R., Dhir, R. K., and Gill, J. P. (1995). "Concrete surface treatment: effect of exposure temperature on chloride diffusion resistance." *Cement and Concrete Research*, Vol. 25, Issue 1, pp. 197-208.

Jovall, O. (2001). "Avoiding early age cracking." *Concrete Engineering International*, Vol. 5, pp. 41.

Kawamura, M. K., and Nakamura, H. (2001). "Development of a bridge management system for existing bridges." *Advances in Engineering Software*, Vol. 32, Issues 10-11, pp. 821-833.

Khan, M. S. (1991). "Corrosion state of reinforcing steel in concrete at early ages." *ACI Materials Journal*, Vol. 88, Issue 1.

Kheder, G. F., Al Rawi, R. S., and Al Dhahi, J. K. (1994). "Study of the behavior of volume change cracking in base-restraint concrete walls." *ACI Materials Journal*, Vol. 91, Issue 2.

Kim, J. K., and Lee, C. S. (1998). "Prediction of differential drying shrinkage in concrete." *Cement and Concrete Research*, Vol. 28, Issue 7, pp. 985-994.

Kmita, A. (2000). "A new generation of concrete in civil engineering." *Journal of Materials Processing Technology*, Vol.106, pp. 80-86.

Kosel, H. C., and Michois, K. A. (1985). "Evaluation of Concrete Deck Cracking for Selected Bridge Deck Structures of the Ohio Turnpike, Report to Ohio Turnpike Commission." *Construction Technology Laboratories (CTL)*.

Kovler, K. (1995). "Shock of evaporative cooling of concrete in hot dry climates." *Concrete International*, Vol. 17, Issue 10, pp. 65-69.

Kraii, P. (1985). "A Proposed Test to Determine the Cracking Potential Due to Drying Shrinkage of Concrete." *Concrete Construction*, Vol. 30, No. 9, pp. 775-779.

Krauss, P.D. (2003). "Practical considerations for materials selection for cracking avoidance." Presentation in meeting # 113, TRB 2003, Washington.

Krauss, P. D., and Rogalla, E.A. (1996). *Transverse Cracking in Newly Constructed Bridge Decks*. NCHRP Report No. 380. Washington, D.C.

Ksomatka, S. H., and Panarese, W. C. (1990). *Design and Control of Concrete Mixtures*. Edition 13, Portland Cement Association.

Kumaat, E., and Lorrain, M. (1996). "Cracking of plain or reinforced high performance concrete slabs." *International Journal of Structures*, Vol. 16, pp. 1.

Kwak, H. G., and Seo, Y. J. (2002). "Shrinkage cracking at interior supports of continuous pre-cast pre-stressed concrete girder bridges." *Construction and Building Materials*, Vol. 16, pp. 35.

Kwak, H. G., Seo, Y. J., and Jung, C. M. (2000). "Effects of the slab casting sequences and the drying shrinkage of concrete slabs on the short-term and long-term behavior of composite steel box girder bridges, Part 2." *Engineering Structures*, Vol. 22, pp. 1467.

La Fraugh, R. W., and Perenchio, W. F. (1989). *Phase I Report of Bridge Deck Cracking Study West Seattle Bridge*. Wiss, Janney, Elstner Associates, Report No. 890716.

Lebet, J. P., and Ducret, J.M. (1998). "Experimental and theoretical study of the behavior of composite bridges during construction." *Proceedings of the 1998 2nd World Conference on Steel in Construction*, Journal of Constructional Steel Research.

Lerch, W. (1957). "Plastic Shrinkage." *Journal of the ACI*, Vol. 53, No. 2, pp. 803-802.

Li, Z., Qi, M., and Ma, B. (1999). "Crack Width of High-Performance Concrete Due to Restrained Shrinkage." *Journal of Materials in Civil Engineering*, Vol. 11, Issue 3, pp. 214-223.

Liang, M. T., Wang, K. L., and Liang, C. H. (1999). "Service life prediction of reinforced concrete structures." *Cement and Concrete Research*, Vol. 29, Issue 9, pp. 1411-1418.

Long, E., Henderson, G. D., and Montgomery, F. R. (2001). "Why assess the properties of near-surface concrete?." *Construction and Building Materials*, Vol. 15, Issues 2-3, pp. 65-79.

Lou, Z., Gunaratne, M., Lu, J. J., and Dietrich, B. (2001). "Application of a Neural Network Model to Forecast Short-Term Pavement Crack Condition: Florida Case Study." *Journal of Infrastructure Systems*, Vol. 7, Issue 4, pp. 166-171.

Lower, D. O. (1980). "Summary Report on Type K Shrinkage-Compensating Concrete Bridge Deck Installations in the State of Ohio." *ACI Special Publication (SP-64-10)*, American Concrete Institute, Detroit, Michigan, pp. 181-192.

Lykke, S., Skotting, E., and Kjaer, U. (2000). "Prediction and Control of Early-Age Cracking: Experiences From the Oresund Tunnel." *Concrete International*, Vol. 22, Issue 9.

Malhotra, V.M., and Hemmings, R.T. (1995). "Blended Cements in North America – A Review." *Cement and Concrete Research*, Issue 17, pp. 23-35.

Manning, D. G. (1981). "Effect of Traffic-induced Vibrations on Bridge Deck Repairs." *NCHRP Synthesis 86*, Transportation Research Board, National Research Council. Washington, D.C.

Mayer, C.W. (1982). "Quality control by the contractor." *Concrete International*, Vol. 4, No. 9, pp. 72-74.

Mc Connell, V. (1999). "Composites make progress in reinforcing concrete." *Reinforced Plastics*, July/August, pp. 40-46.

McDonald, J. E. (1992). "The Potential for Cracking of Silica-Fume Concrete." *Concrete Construction*.

Mehta, P. K. (1986). *Concrete Structure, Properties, and materials*. Prentice Hall, New Jersey.

Meyers, C. (1982). "Survey of Cracking on Underside of Classes B-1 and B-2 Concrete Bridge Decks in District 4." Investigation 82-2, Missouri Highway and Transportation Department, Division of Materials and Research.

Mietz, J., and Isecke, B. (1996). "Monitoring of concrete structures with respect to rebar corrosion." *Construction and Building Materials*, Vol. 10, Issue 5, pp. 367-373.

Mohamed, O. A., Rens, K. L., and Stalnaker, J. J. (2000). "Factors Affecting Resistance of Concrete to Freezing and Thawing Damage." *Journal of Materials in Civil Engineering*, Vol. 12, Issue 1, pp. 26-32.

Mokarem, D.W. (2002). *Development of concrete shrinkage performance specifications*. Ph. D. Dissertation, Virginia Polytechnic Institute and State University.

Mokarem, D.W., Weyers, R.E., and Lane, D.S. (2003). "Development of Portland cement concrete shrinkage performance specifications." *TRB 2003 Annual meeting CD-Rom*.

Montemor, M.F., Cunha, M.P., Ferreira, M.G., and Simoes, A.M. (2002). "Corrosion behavior of rebars in fly ash mortar exposed to carbon dioxide and chlorides." *Cement and Concrete Composites*, Vol. 24, pp. 45-53.

Nagi, M., Janssen, D., and Whiting, D. (1994). "Durability of concrete for early opening of repaired highways--Field evaluation." *ACI Special Publication (SP-145)*, Volume 145.

Naik, T. R., Shiw, S. S., and Hossain, M. M. (1995). "Properties of high performance concrete systems incorporating large amounts of high-lime fly ash." *Construction and Building Materials*, Vol. 9, Issue 4, pp. 195-204.

Nehdi, M. (2001). "Ternary and Quaternary Cements for Sustainable Development." *Concrete International*, Vol. 23, Issue 04.

Neville, A.M. (2000). "The question of concrete durability: We can make good concrete today." *Concrete International*, Vol. 22, Issue 7, pp. 21-26.

Neville, A.M. (1999). "Specifying concrete for slipforming." *Concrete International*, Vol. 21, Issue 11, pp. 61-63.

Neville, A.M. (1995). *Properties of concrete*. Longman Group, 4th edition.

Nishida, N., Ushioda, K., Dobashi, Y., and Matsui, K. (1995). "Evaluation of thermal cracking index in slab-concrete under uncertain parameters." *Transactions of the Japan Concrete Institute*, Vol. 17, pp. 127.

Nmai, C. K. (1998). "Cold Weather Concreting Admixtures." *Cement and Concrete Composites*, Vol. 20, Issues 2-3, pp. 121-128.

Nmai, C., Tomita, R., Hondo, F., and Buffenbarger, J. (1998). "Shrinkage-Reducing Admixtures." *Concrete International*, Vol. 20, Issue 4.

Ohama, Y., Demura, K., Satoh, Y., Tachibana, K., and Miyazaki, Y. (1989). "Development of Admixtures for Highly Durable Concrete." *ACI Special Publication (SP-119-17)*, pp. 321-342.

Osretgaard, L., Lange, D.A., Altaubat, S.A., and Stang, H. (2001). "Tensile basic creep of early-age concrete under constant load." *Cement and Concrete Research*, Vol. 31, Issue 12, pp. 1895-1899.

Ozyildirim, C., and Lane, D.S. "Investigation of self leveling concrete." TRB 2003 Annual meeting Proceedings.

"PCA-concrete basics." (2003).

[http://www.portcement.org/cb/concretebasics\\_concretebasics.asp](http://www.portcement.org/cb/concretebasics_concretebasics.asp), (June 12, 2003).

Pedefferri, P. (1996). "Cathodic protection and cathodic prevention." *Construction and Building Materials*, Vol. 10, No. 5, pp. 391-402.

Perfetti, G. R., Johnson, D. W., and Bingham, W. L. (1985). "Incidence Assessment of Transverse Cracking in Concrete Bridge Decks." *Structural Consideration*, FHWA/NC/85-002 Vol. 2.

Perragaux, G. R., and Brewster, D. R. (1992). *In-Service Performance of Epoxy-Coated Steel Reinforcement in Bridge Decks-Final Report*. New York State Dept. of Transportation Technical Report 92-3.

Pettersson, D., and Thelandersson, S. (2001). "Crack development in concrete structures due to imposed strains - Part I: Modelling." *Materials and Structures/Material Constructions*, Vol. 34, pp. 7.



- Pheeraphan, T., and Leung, C. K. Y. (1997). "Freeze-thaw durability of microwave cured air-entrained concrete." *Cement and Concrete Research*, Vol. 27, Issue 3, pp. 427-435.
- Phelan, W.S. (2000). "Admixtures and aggregates: Key elements of athletic concrete." *Concrete International*, Vol. 22, Issue 4, pp. 35-39.
- Phillips, M.V., Ramey, G.E., and Pittman, D.W. (1997). "Bridge deck construction using Type K cement." *Journal of Bridge engineering*.
- Popovic, P., Rewerts, T. L., and Sheahen, D. J. (1988). "Deck Cracking Investigation of the Hope Memorial Bridge." *Ohio Department of Transportation*.
- Portland Cement Association, (1970). *Final Report-Durability of Concrete Bridge Deck--A Co-operative Study*.
- Purvis, R. L. (1989). "Prevention of Cracks in Concrete Bridge Decks." *Wilbur Smith Associates*, Report on Work in Progress.
- Ramakrishnan, V., and Mc Donald, C.N. (1997). "Durability evaluations and performance histories of projects using polyolefin fiber reinforced concrete." *ACI Special Publication 170*, paper 35, pp. 665-680.
- Ramey, G. E., Stallings, J. M., and Oliver, R. S. (1999). "Cracking damage/deterioration and rehabilitation considerations of some Birmingham, Alabama, Interstate bridge decks." *Transportation Research Record*, pp. 33.
- Randall, F. A. (1980). "Field Study of Shrinkage Compensating Cement Concrete." *ACI Special Publication (SP-64-13)*, American Concrete Institute, Detroit, Michigan, pp. 239-257.
- Rawi, R. S. A., and Kheder, G. F. (1990). "Control of Cracking Due to Volume Change in Base-Restrained Concrete Members." *ACI Structural Journal*, Vol. 87, No. 4, pp. 397-405.
- Razek, M. M. A., and Enein, S. A. A. (1999). "Moisture performance through fresh concrete at different environmental conditions." *Cement and Concrete Research*. 29, 1819-1825.

Redston, J. (1999). "Canada's infrastructure benefits from FRP." *Reinforced Plastics*, July/August, pp. 33-34.

Reed, R. C. (1993). "Cracking--An early warning of structural problems." *Concrete International*, Vol. 15, Issue 9.

Reis, E. E. Jr., Mozer, J. D., Bianchini, A. C., and Kesler, C.E. (1964). "Causes and Control of Cracking in Concrete Reinforced with High Strength Steel Bars-A Review of Research." *T. & A.M. Report No. 261*, Department of Theoretical and Applied Mechanics, University of Illinois, Urbana, Illinois.

Rhodes, C. C. (1950). "Curing Concrete Pavements with Membranes." *Journal of the ACI*, Vol. 57, No. 12, pp. 277-295.

Rhodes, J.A., and Carreira, D. (1997). "Prediction of creep, shrinkage, and temperature effects in concrete structures." *ACI Manual of Concrete Practice*, Vol. 1, Report 209-R.

Rixom, R., and Mailvaganam, N. (1999). *Chemical admixtures for concrete*, Third Edition, E & FN Spon, London, England.

Rixom, R., and Mailvaganam, N. (1999). *Chemical admixtures for concrete*, Routledge, Newyork.

Ronneberg, H. (1989). "Use of chemical admixtures in concrete platforms." *ACI Special Publication 119*, paper 27, pp. 517-533.

Rostam, S. (1996). "High performance concrete cover--why it is needed, and how to achieve it in practice." *Construction and Building Materials*, Volume 10, Issue 5, Pages 407-421.

Russell, H. G. (1980). "Performance of Shrinkage-Compensating Concretes in Slabs." *ACI Special Publication (SP-65-6)*, American Concrete Institute, Detroit, Michigan, pp. 81-114.

Sabir, B. B. (1997). "Mechanical Properties and Frost Resistance of Silica Fume Concrete." *Cement and Concrete Composites*, Vol. 19, Issue 4, pp. 285-294.

- Samman, T.A., Mirza, W.H., and Wafa, F.F. (1996). "Plastic shrinkage cracking of normal and high strength concrete: a comparative study." *ACI Material Journal*, Vol. 93, pp. 36-40.
- Samples, L.M., and Ramirez, J.A. (2000). "Field investigation of concrete bridge decks in Indiana." *Concrete International*, Vol. 22, Issue 2, pp. 53-56.
- Schiessl, P. (1996). "Durability of reinforced concrete structures." *Construction and Building Materials*, Vol. 10, Issue 5, pp. 289-292.
- Schmitt, T.R., and Dawin, D. (1999). "Effect of material properties on cracking in bridge decks." *Journal of Bridge Engineering*.
- Sellevlod, E. J. (1996). "High-performance concrete: early age cracking, pore structure, and durability." *ACI Special Publication (SP-159)*, Vol. 159.
- Shaeles, C.A. (1988). "Influence of mix proportions and construction operations on plastic shrinkage cracking in thin slabs." *ACI Material Journal*, Vol. 85, pp. 495-504.
- Shah, S. P., Marikunte, S., Yang, W., and Aldea, C. (1996). "Control of cracking with shrinkage-reducing admixtures." *Transportation Research Record*, pp. 25.
- Shah, S. P., Weiss, W. J., and Yang, W. (1998). "Shrinkage cracking - can it be prevented?" *Concrete International*, Vol. 20, pp. 51.
- Shah S.P., and Ahmad S.H. (1994). *High performance concretes and applications*, Great Britain.
- Shi, Z., and Nakano, M. (2001). "Application of a 3-D crack analysis model to RC cantilever decks of excessive cracking." *Structural Engineering and Mechanics*, Vol. 12, pp.377.
- Shihata, S. A., and Baghdadi, Z. A. (2001). "Simplified Method to Assess Freeze-Thaw Durability of Soil Cement." *Journal of Materials in Civil Engineering*, Vol. 13, Issue 4, pp. 243-247.
- Shilstone, J. M. Jr., and Shilstone, J. M. (2002). "Performance based concrete mixtures and specifications for today." *Concrete International*, Vol. 24, Issue 2, pp. 80-83.

Siebel, E. (1989). "Air-void characteristics and freezing and thawing resistance of superplasticized air entrained concrete with high workability." *ACI Special Publication 119*, paper 16, pp. 297-319.

Simonsen, E., Janoo, V. C., and Isacson, U. (1997). "Prediction of Pavement Response during Freezing and Thawing Using Finite Element Approach." *Journal of Cold Regions Engineering*, Vol. 11, Issue 4, pp. 308-324.

Smith, J.L., and Virmani, Y.P. (2000). *Materials and methods for corrosion control of reinforced and prestressed concrete structures in new construction*, LTTP publication No: 00-091.

Spellman, D. L., Woodstrom, J. H., and Baily, S. N. (1973). "Evaluation of Shrinkage Compensated Cement." Materials and Research Department, California Division of Highways, CA-HY-MR-5216-1-73-15.

Stewart, M.G., and Rosowsky, D.V. (1998). "Time dependent reliability of deteriorating reinforced concrete bridge decks." *Structural Safety*, Vol. 20, pp. 91-109.

Stewart, C. F., and Gunderson, B. J. (1969). "Factors Affecting the Durability of Concrete Bridge Decks-Interim Report #2." Report by the Research and Development Section of the Bridge Department, State of California.

Suh, Y., and McCullough, B. F. (1994). "Factors affecting crack width of continuously reinforced concrete pavement." *Transportation Research Record*, pp. 134.

Sun, W., Zhang, Y. M., Yan, H. D., and Mu, R. (1999). "Damage and damage resistance of high strength concrete under the action of load and freeze-thaw cycles." *Cement and Concrete Research*, Vol. 29, Issue 9, pp. 1519-1523.

Swamy, R.N. (1997). "Design for durability and strength through the use of fly ash and slag in concrete." *ACI Special Publication 171*, paper 1, pages 1-72.

Swamy, R.N. (1989). "Super plasticizers and concrete durability." *ACI Special Publication 119*, article 19, pages 363-382.

Tamtsia, B.T., and Beaudain, J.J. (2000). "Basic tensile creep of hardened cement paste, a reexamination of the role of the water." *Cement and Concrete Research*, Vol. 30, pp. 1465-1475.

Tang, T., Zollinger, D. G., and Yoo, R. H. (1993). "Fracture toughness of concrete at early ages." *ACI Materials Journal*, Vol. 90, Issue 5.

Tay, D. C. K., and Tam, C. T. (1996). "In situ investigation of the strength of deteriorated concrete." *Construction and Building Materials*, Vol. 10, Issue 1, pp. 17-26.

Taylor, H.F.W. (1990). *Cement Chemistry*, Academic Press Ltd, London, England.

Toutanji, H. A. (1999). "Durability characteristics of concrete columns confined with advanced composite materials." *Composite Structures*, Vol. 44, pp 155-161.

Ulm, F. J., and Coussy, O. (2001). "What is a 'Massive' Concrete Structure at Early Ages? Some Dimensional Arguments." *Journal of Engineering Mechanics*, Vol. 127, Issue 5, pp. 512-522.

Uzzafar, R. (1992). "Influence of cement composition on concrete durability." *ACI Materials Journal*, Vol. 89, Issue 6.

Van der Veen, C., Koenders, E. A. B., and Kaptijn, N. (1996). "Thermal cracking in a cantilever bridge made of HSC." *Computing in Civil Engineering (New York)*, pp. 892.

Wang K., Jansen D., and Shah, S.P. (1997), "Permeability of cracked concrete." *Cement and Concrete Research*, Vol.27, No.3, pp. 381-393.

Wang, Q., Zhang, T., and Zhao, G. (2001). "Analysis of biaxial bending of reinforced concrete slabs with simply support under concentrated loads." *Journal of Dalian University of Technology*, Dalian Ligong Daxue Xuebao, Vol. 41, pp. 481.

Weiss, W. J., Yang, W., and Shah, S. P. (2000). "Factors Influencing Durability and Early-Age Cracking in High-Strength Concrete Structures." *ACI Special Publication*, Vol. 189.

Whiting, D., and Schmitt, J. (1989). "A model for deicer scaling resistance of field concretes containing high-range water reducers." *ACI Special Publication 119*, paper 18, pp. 343-359.

Wiegrink, K., Marikunte, S., and Shah, S. (1996). "Shrinkage cracking of high strength concrete." *ACI Materials Journal*, Vol. 93, Issue 5, pp. 409-415.

Wong, G.S., Alexander, A.M., Haskins, R., Poole, T.S., Malone, P.G., and Wakeley, L. (2001). *Portland Cement concrete rheology and workability – Final report*, FHWA report (FHWA-RD-00-025).

Wood, J. G. M., and Crerar, J. (1997). "Tay road bridge: analysis of chloride ingress variability & prediction of long-term deterioration." *Construction and Building Materials*, Vol. 11, Issue 4, pp. 249-254.

Xu, Y., and Chung, D.D.L. (2000), "Reducing the drying shrinkage of cement paste by admixture surface treatments." *Cement and Concrete researches*, Vol. 30, pp. 241-245.

Xu, Y., and Chung, D.D.L. (2000), "Improving silica fume cement by Silane." *Cement and Concrete Research*, Vol. 25, pp1305-1311.

Zhou, Y., Cohen, M. D., and Dolch, W. L. (1995). "Effect of external loads on the frost-resistant properties of mortar with and without silica fume." *ACI Materials Journal*, Vol. 91, Issue 6.